

PART 8 INDOOR CYCLING - ARTISTIC CYCLING

Version 01.01.2017 / 8-INA-20160801-E

TABLE OF CONTENTS

	Page
Chapter I PRELIMINARY NOTES.....	3
§ 1 Organizations	3
§ 2 Disciplines and age-groups	4
§ 3 Competition area	5
§ 4 Equipment	7
§ 5 Evaluation sheet.....	9
§ 6 Commissaires.....	11
§ 7 Tasks of the Commissaires	12
§ 8 Judgement of difficulty.....	13
§ 9 Judgement of difficulty valid for single and pair.....	15
§ 10 Judgement of difficulty valid for pair.....	17
§ 11 Judgement of difficulty valid for artistic cycling team 4 and 6.....	18
§ 12 Judgement of performance.....	19
Chapter II GUIDELINES FOR SINGLE AND PAIR ARTISTIC CYCLING.....	23
§ 1 General guidelines on single and pair riding programmes	23
§ 2 General guidelines for the pair riding programme	24
§ 3 Guidelines for performance on the riding-area single and pair.....	25
§ 4 Guidelines for performance on bicycle single and pair.....	28
Chapter III GUIDELINES ARTISTIC CYCLING TEAM 4 AND 6.....	32
Chapter IV TABLE OF FIGURES SINGLE ARTISTIC CYCLING	41
Chapter V EXPLANATIONS OF FIGURES SINGLE ARTISTIC CYCLING	53
Chapter VI TABLE OF FIGURES PAIR ARTISTIC CYCLING.....	66
Chapter VII EXPLANATIONS OF FIGURES PAIR ARTISTIC CYCLING	82
Chapter VIII TABLE OF FIGURES ARTISTIC CYCLING TEAM 4	98
Chapter IX EXPLANATIONS OF FIGURES ARTISTIC CYCLING TEAM 4.....	110
Chapter X TABLE OF FIGURES ARTISTIC CYCLING TEAM 6	165
Chapter XI EXPLANATIONS OF FIGURES ARTISTIC CYCLING TEAM 6.....	179

TABLE OF ABBREVIATIONS / TERMS

Abbreviations and terms used in the regulations, in alphabetical order:

1 leg	with one leg
50 cm	50 centimetres
8	eight
bw.	backward
C.	complete circle
cm	centimetres
con.	connected
count. C	counter circle
count. 8	counter eight
count. X8	counter cross eight
count. s.r.	counter single rings
dir.	direction
f.e.o.	following each other
frh.	free-hand
h/b.	handlebar
HC.	half circle
HS	half surrounding
indiv.	individual
mm	millimetres
n.e.o.	next to each other
one a. anot.	one after another
opp.	opposite
P.	passage
reg.	regular
rev.	reverse
S	half eight
sdw.	sideward
sim.	simultaneous
spin.	spinnings
s.r.	single rings
s.r.l.	single rings left
s.r.r.	single rings right
str.	stretch
T	tactical figure

PART 8 INDOOR CYCLING - ARTISTIC CYCLING

Chapter I PRELIMINARY NOTES

§ 1 Organizations

8.1.001 Organization of competitions

Competitions can be organized by the International Cycling Union (UCI), the continental federations, the national federations and their subordinate bodies. For publications and invitations the UCI or national regulations are valid.

8.1.002 *World Championships*

World Championships will be organized in the age-group Elite (women/men).

8.1.003 Disciplines of competitions

- Single artistic cycling
- Pair artistic cycling
- Artistic Cycling Team 4
- Artistic Cycling Team 6

Each discipline can be organized (separate) for female and male competitors.

Mixed (women and men) teams will start in the respective male discipline. Each rider is allowed to enter only once per discipline at an event (competition or championship).

International competitions for Artistic Cycling Team 4 were held as an open discipline.

(text modified on 01.01.16)

8.1.004 Records

World- and continental records can be set in the age-groups Elite and Junior. These records can be achieved at world championships, continental championships and international competitions.

World- and continental records, achieved at *World- and Continental Championships*, will be accepted immediately.

World- and continental records, achieved at international competitions, only will be accepted when two UCI-Commissaires with different nationalities are present in the Commissaires Panel responsible for the evaluation. These records have to be confirmed by the UCI.

National records will be accepted according to the rules of the respective national federation.

(text modified on 01.01.16)

- 8.1.005** Ranking lists
At all events the organizer has to publish the results at the end of each discipline.

(text modified on 01.01.16)

- 8.1.006** Ranking lists of international competitions
Ranking lists have to be submitted to the UCI-office in the required form within the defined period.
If there are riders in the Elite and the Junior age-groups (splitted by sex and disciplines) the rankings have to be submitted as combined ranking list to the UCI.

(text modified on 01.01.16)

- 8.1.007** Hand-out of evaluation sheets
After finishing a discipline the evaluation sheets/electronic judging documents have to be submitted to the corresponding person. The evaluation sheets have to be treated confidentially and may only be submitted to the concerning head of delegation, coach or rider. At *World Championships*, the evaluation sheets have to be submitted to the head of delegation.

(text modified on 01.01.16)

§ 2 Disciplines and age-groups

- 8.1.008** Age-groups
Artistic cycling competitions will be announced to:
- A. Elite over 18 years
 - B. Juniors, female/male U19 (up to 18 years)
 - C. Pupils, female/male, U15 (up to 14 years)
 - D. Pupils, female/male, U13 (up to 12 years)
 - E. Pupils, female/male, U11 (up to 10 years)

In the year of completion the corresponding age, pupils and juniors are allowed to compete in the same age-group until the end of the calendar year. It is possible to compete in the next higher age-group. Pupils of age-group U13 or U11 are also allowed to compete two age-groups higher.

It is possible for 1 rider up to 22 years (U23) to compete in an artistic cycling team 4 juniors.

It is possible for 1 rider up to 16 years (U17) to compete in an artistic cycling team 4 pupils.

It is possible for 2 riders up to 22 years (U23) to compete in an artistic cycling team 6 juniors.

It is possible for 2 riders up to 16 years (U17) to compete in an artistic cycling team 6 pupils.

(text modified on 01.01.16)

- 8.1.009** Length of performance
For all disciplines and age-groups the maximum time for the execution of the complete programme is 5 minutes.

(text modified on 01.01.16)

Amount of figures

- 8.1.010** Age-groups Elite and Junior
- Single artistic cycling: max. 30 figures
 - Pair artistic cycling: max. 25 figures (with a minimum of 8, but a maximum of 15 figures on one bicycle)
 - Artistic Cycling Team 4: max. 25 figures
 - Artistic Cycling Team 6: max. 25 figures

- 8.1.011** Age-group pupils
- Single artistic cycling: max. 25 figures
 - Pair artistic cycling: max. 20 figures (with a minimum of 4, but a maximum of 12 figures on one bicycle)
 - Artistic Cycling Team 4: max. 25 figures
 - Artistic Cycling Team 6: max. 25 figures

bis In general for pair artistic cycling, a team is required to perform figures on one, but also on two bicycles during their performance.

§ 3 Competition area

- 8.1.012** Riding-area
All measures are taken at the outside of the markings. All mentioned markings have to be applied at the riding-area exactly according to this drawing.

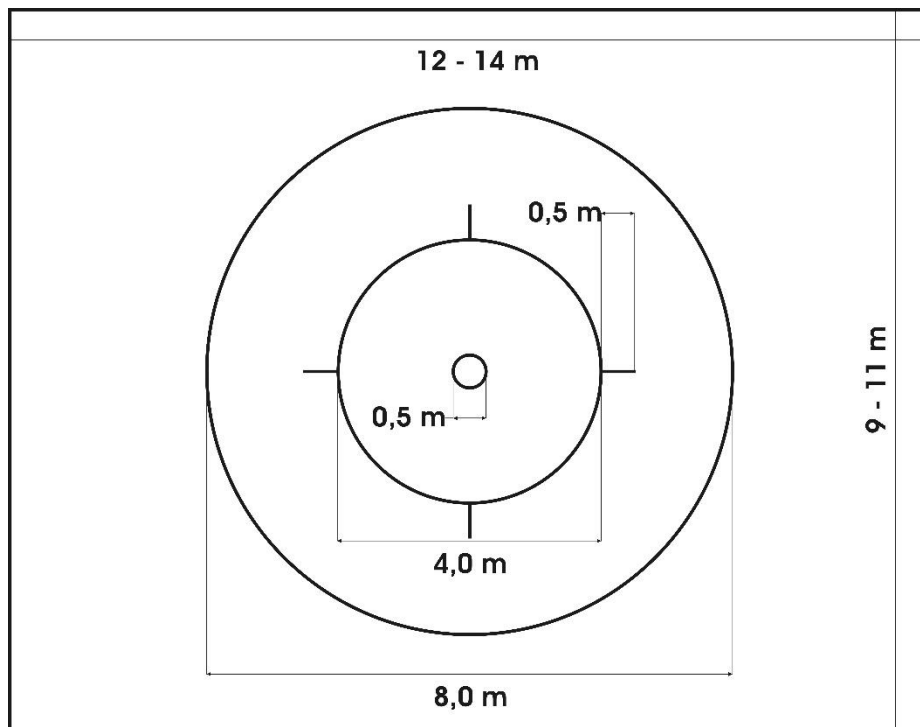

Any markings have to have the width of 3.0 to 5.0 centimetres. They may be applied by tape, paint or can be inserted in the floor.

At international championships and competitions the riding-area must have the maximum dimensions.

The markings must be visible for all judges.

The matchfield-railings and the goals used for cycle ball must be placed at least 0.5 metres outside the riding-area markings during artistic cycling competitions.

The minimum distance of the riding-area from walls, columns or nonremovable objects must be at international championships 2.0 metres, at other competitions 0.5 metres.

The composition of the riding-area has to allow a correct performance.

(text modified on 01.01.16)

8.1.013 Placement of the judges

The judges must be placed at the riding-area, where they have a good view to the riding-area and their independence is guaranteed.

(text modified on 01.01.16)

8.1.014 Coaching zone

A coaching zone (for a coach and an assistant) has to be defined before the start of the competition by the Chief-Commissaire in cooperation with the organizer (2 metres width and with at least a distance of 0.5 metres to the border of the riding-area). In case of electronic judging the display of the official time must be seen from the coaching zone.

(text modified on 01.01.16)

8.1.015 Time measurement

In case of electronic judging the display shows the official time. In case of manual judging the time and the acoustic signal has to be occurred with another visual display or a timekeeper has to announce the first minute.

(article introduced on 01.01.16)

8.1.016 Support lines

It is not allowed to apply the support lines at the riding-area. They only are used here to understand the following explanations.

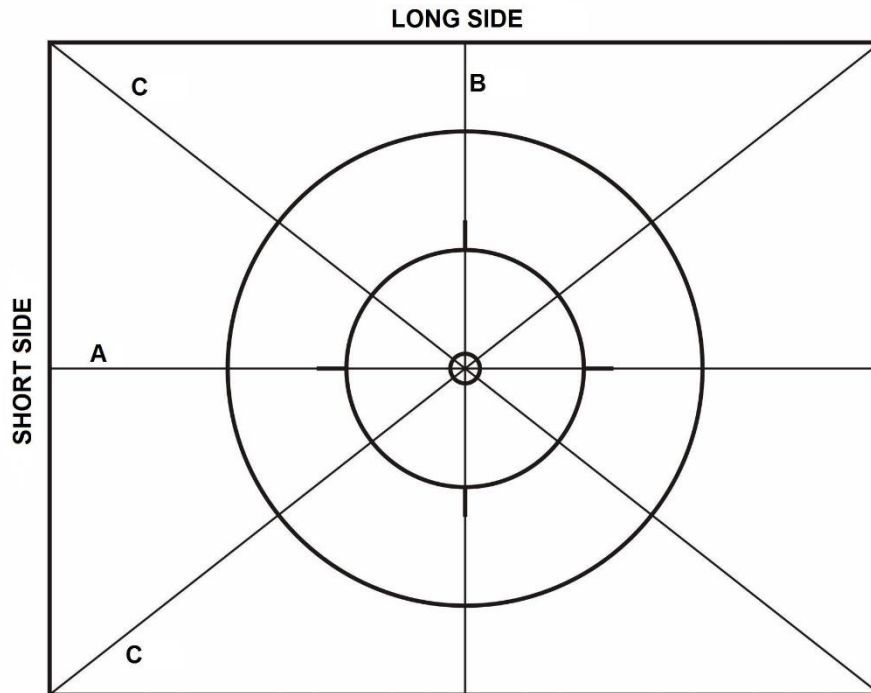

- **Inner circle:** Circle around the middle point of the riding-area with a diametre of 50 centimetres.
- **Quarter stripes:** The quarter stripes (4) start at the outside of the middle circle and are positioned on the middle lines A and B. They have each a length of 50 centimetres.
- **Middle circle:** Circle in the middle of the riding-area with a diametre of 4.0 metres.
- **Outer circle:** Circle in the middle of the riding-area with a diametre of 8.0 metres.
- **Middle longitudinal axis (support line A):** Line parallel to the long side of the riding-area through the middle of the riding-area.
- **Middle transverse axis (support line B):** Line parallel to the short side of the riding-area through the middle of the riding-area.
- **Diagonal axis (support line C):** Lines from one corner to the opposite corner through the middle of the riding-area.

(text modified on 01.01.16)

§ 4 Equipment

8.1.017 Bicycle

All aids not mentioned in the document above are forbidden.

The construction of the bicycles must correspond to the following guidelines and measures. All deviations which do not correspond with the stated measures have to be approved – in advance – by the UCI.

The bicycle has to be constructed in a way that it is not possible to damage the riding-area.

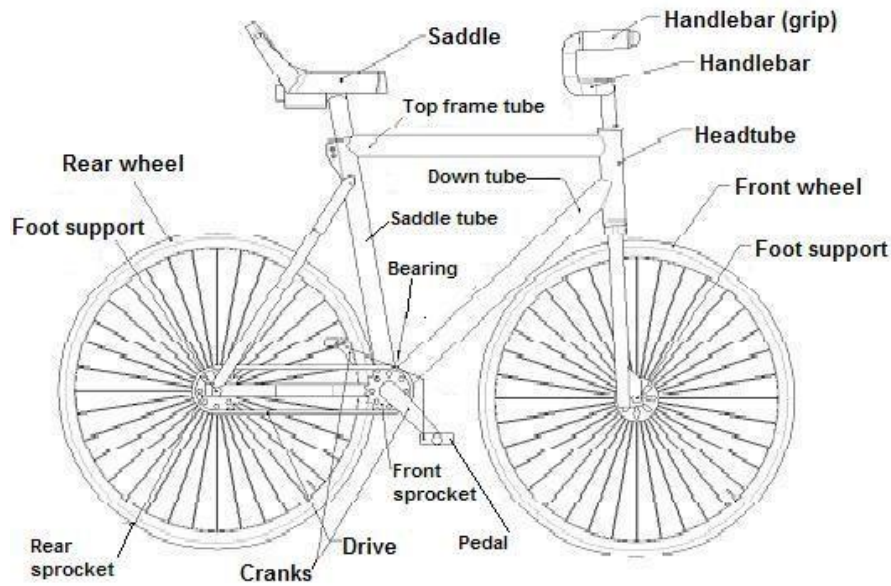

- **Cranks:** Length from centre bottom bracket bearing to centre pedal pivot shaft 130 – 170 mm.
- **Handlebar:** The end of the handlebar must be rounded off or closed by grips. The use of handlebar-tape instead of grips is allowed.
- **Saddle:** The saddle must be a manufactured part. Maximum length 300 mm, maximum width 220 mm, maximum bent (without weight) 60 mm.
- **Wheels:** Front and rear wheel must have the same diameter. From the height of frame of 46 cm the wheels must have a diameter of at least 24 inches, from 50 cm height of frame the wheels diameter must be at least 25 inches.
- **Transmission:** The front sprocket may not have less teeth than the rear sprocket. Alternative mechanical drives are allowed with respect to the described transmission.
- **Foot support:** In single- and pair artistic cycling it is allowed to equip the axis of both wheels, on both sides, with foot-supports, each with a maximum length of 50 mm.

(text modified on 01.01.16)

8.1.018 Sports wear

At artistic cycling competitions the rider(s) must wear appropriate clothes.

8.1.019 Musical accompaniment

Any riding programme may be shown accompanied by music. If riders want to perform to a particular piece of music, the rider(s) themselves have to provide the music.

§ 5 Evaluation sheet

8.1.020 Completing of the evaluation sheet

The top part of the evaluation sheet has to be fully completed. Care should be taken so that only one figure out of each group of figures a, b, c etc. may be listed on the evaluation sheet, therefore each number may only appear once.

The number of the figure, the context of the figure and the point values have to be filled in on the evaluation sheet exactly as in the table of figures. The point values will have to be added and the total of points registered.

It is free for the rider(s) to sequence the figures on the evaluation sheet according to her/his wishes, but during the competition the written order has to be followed exactly.

(text modified on 01.01.16)

8.1.021 Exceptions

After a raiser passage a raiser figure according to the corresponding end position of the passage has always to be showed.

Pairs are allowed to show a maximum of 3 turns on the spot.

The same maximum of 3 figures is valid for figures with the affix "separate" (Exception: Passages on two bicycles).

(text modified on 01.01.16)

8.1.022 Evaluation sheet sample

In all competitions or championships it is only allowed to use the evaluation sheet shown on this page.

Evaluation-Sheet for artistic-cycling-competition

UCI-Code:	Surname, Firstname:	Discipline:	Starting-number:
		Pers.Record: Pts. on:	
		Federation:	
		Club:	
		Competition:	
		Day/Place:	
		Organizer:	

Seq. No.	Exercise- No.	Name of Exercise	Tact. Points	Value	Difficulty %	Performance Pts.	Performance Signs
1							
2							
3							
4							
5							
6							
7							
8							
9							
10							
11							
12							
13							
14							
15							
16							
17							
18							
19							
20							
21							
22							
23							
24							
25							
26							
27							
28							
29							
30							

Checked Announcer: Writer: Chief:	DIFFICULTY POINTS: + Tactical points: TOTAL POINTS: - Total subtraction diff./performance RESULT: + Result judginggroup II + Result judginggroup III FINAL RESULT	Substraction Difficulty: _____ _____ X 0,2 = _____ _____ ~ x 0,5 = _____ _____ x 1,0 = _____ _____ O x 2,0 = _____ Substraction Perform.: _____ Total Substraction: _____ : 2 oder 3 = _____ Points
--	--	--

(text modified on 01.01.16)

8.1.023 Check of evaluation sheet

Is an electronic judging system used in a competition the rider/coach is required to check, correct and sign the evaluation sheet he received from the commissaires panel.

From 1 hour before start of the corresponding discipline it is not allowed to change the evaluation sheet anymore.

Possible disadvantages due to mistakes on the evaluation sheet are in the responsibility of the rider.

(text modified on 01.01.16)

8.1.024 Evaluation of the results

The registered points (at start) are the added total of the separate point values of the figures. When a tactical figure is presented the respective addition of points has to be added by the commissaires during the performance.

The total devaluation is being calculated from the devaluation of difficulty and the devaluation of performance. The total devaluation subtracted from the registered (+ tactical addition) points is the result.

The final result is being calculated by the total of the single results from the judging groups, divided by the number of judging groups and is to be rounded to two digits after the point.

If two or more riders should end up with the same final result, the better performance will decide about the placement. In the case it's the same, the riders will receive the same place in the ranking.

The final result of each competition has to be published as soon as possible by the Chief-Commissaire or organizer.

Results, below zero, are not to be published. Only the rankings, based on the subtractions, are to be published.

(text modified on 01.01.16)

§ 6 Commissaires

8.1.025 Responsibility of the Commissaires

Any evaluation has to be conducted under the personal responsibility of the commissaire without influence from anybody else and has to be based only on the valid regulations.

All judges are obliged to be totally neutral towards riders.

Once an evaluation is published by the total jury, it will have to be protected by each single commissaire.

8.1.026 Appointment of Commissaires (= judges)

The commissaires for international championships will be appointed by the authorized international federations. For all other competitions the national federations or the adequate divisions will be responsible for nomination of the judges.

All the commissaires appointed at competitions or championships must hold an adequate license, corresponding to the respective category.

At international competitions at least one of the judges must hold an international license.

For UCI-calendar competitions separate UCI rules are valid.

Composition Commissaires panel

8.1.027 International Championships:

- 1 commissaire as Chief Commissaire;
- 3 announcing Commissaires;
- 3 writing Commissaires;

The single judging group consists of an announcer and a writing judge. They must speak the same language.

8.1.028 Other competitions:

- 1 commissaire as Chief Commissaire;
- 2-3 announcing Commissaires;
- 2-3 writing Commissaires;

bis The single judging group consists of an announcer and a writing judge. It is recommended that they speak the same language.

§ 7 Tasks of the Commissaires

8.1.029 Commissaires panel

- All the judges are responsible for the evaluation and are required to sign the evaluation sheet (not necessary when an electronic judging system is used).
- The judges have to check and to approve the correct composition (measures and condition) of the riding-area to guarantee a correct performance.
- The judges are required to check and to sign the evaluation sheets when the manual judging system (paper) is used. Faults in the evaluation sheet must be corrected in advance of the competition, if possible together with the rider or his coach.

(text modified on 01.01.16; 01.01.17)

8.1.030 The Chief Commissaire

- decides on the composition of the judging groups.
- is allowed to assemble meetings of the commissaires panel to guarantee the performance of the panel.
- hands the evaluation sheets to the judges.
- will give a signal (acoustically or visually) for the start.
- will clock the length of the performance mechanically or electronically, and will give an acoustic signal at the end of the official maximal maximum time. It is possible to transfer this task to a separate time-keeper, which has to be situated next to the Chief Commissaire.
- a second (spare) time system has to be used in case of malfunctions.
- in case a rider forgets the 'START' call at the beginning of the performance, the Chief Commissaire will determine the moment of starting the time.
- is observing the performance closely in order to be able to decide in case of interruptions or extra ordinary occurrences.
- after the end of each performance the Chief Commissaire verifies the evaluation sheet of each judging group.
- Is responsible that obvious judging mistakes will be corrected (if possible before the start of the next rider) by majority decision of the entire commissaires panel.
- the Chief Commissaire will check the evaluation calculations on each sheet and will sign the sheet in the case of manual judging. The Chief

Commissaire is responsible for publishing the result and ensuring that the evaluation sheets will be submitted to the correct person.

- in case of a defect bicycle and/or an injured rider the Chief Commissaire will stop the official time, but will not stop the second time system. In such a case the Chief Commissaire has to determine the time left. He will decide whether a defect can be blamed on the rider. In this time, the possible, used repair time is part of the regular riding-time.

It is up to the Chief Commissaire to decide whether or not and in which position a programme can be continued.

In the case of an injury or illness a doctor should be consulted in the case this seemed to be necessary. If the rider continues the performance and the interruption was not his fault, given devaluations must be revoked by decision of the judges.

(text modified on 01.01.16; 01.01.17)

8.1.031 Announcing Commissaire

- will follow the progress of the programme to judge the difficulty and accuracy of the performance. After each figure the announcing judge will inform the writing judge if the execution was correct or should be devalued.

(text modified on 01.01.16)

8.1.032 Writing Commissaire

- will read, clearly, the figure text according to the sequence on the evaluation sheet to the announcing judge.
- will write the announced devaluation ~~by the announcing judge,~~ on the correct line of the respective figure on the evaluation sheet.

(text modified on 01.01.16; 01.01.17)

§ 8 Judgement of difficulty

8.1.033 Decisive for the judgment of difficulty are:

The preliminary notes, the guidelines for single and pair artistic cycling, as well as artistic cycling team 4 and 6 and the explanations in the tables of figures. The following regulations of the judgement of difficulty have to be used when below noted mistakes occur during the performance.

(text modified on 01.01.16)

8.1.034 Sequence

If the sequence of figures is not performed according to the programme, the skipped figures are to be devalued with: **100%**

If more figures have a mixed sequence the commissaires panel will decide about the devaluations by majority decision.

(text modified on 01.01.16)

8.1.035 Start of evaluation (judgement)

As soon as the rider(s) enters the riding-area the evaluation will start. Riders will present themselves, standing on the riding-area.

If the rider(s) are not presenting themselves standing on the riding-area, the first figure will be devalued with: **100%**

(text modified on 01.01.16)

8.1.036 Start of performance

Each performance will start with a clear "START" call, announced by the performing rider. If not, there will be a devaluation:

1. for squats, jumps, turns on the spot and passages: **100%**
2. for all other figures: **50%**

(text modified on 01.01.16)

8.1.037 Start of a figure

1. Each figure starts with its prescribed position, if necessary with its prescribed grip connection and taking into account the explanations in the tables of figures. Deviations from this have to be devalued: **100%**
2. Line figures (Artistic cycling team 4 and 6) start independently of the riders distance to the riding-area's border, but they end 1 metre before the end of the riding-area. A devaluation occurs corresponding the missing way of stretch.
3. Half eights start independently from the longitudinal or transverse axis after reaching the starting position of the figure, a devaluation occurs corresponding the missing way of stretch.
4. Counter circles and counter eights start independently from the touch of hands always on the inner circle, a devaluation occurs corresponding the missing way of stretch.
5. If a touch of hands over the inner circle at the beginning or at the end of a figure is required, but is not shown, devaluation of: **10%**

(text modified on 01.01.16)

8.1.038 Not recognisability of figures

All figures listed on the evaluation sheet have to be shown according to the explanations in these regulations. Figures which cannot be recognized will have to be devalued: **100%**

(text modified on 01.01.16)

8.1.039 Way of stretch

The way of stretch is the description for the whole process of a figure which is determined in the preliminary notes and/or in the explanations of figures in the corresponding tables.

All figures on the evaluation sheet must be entirely shown by all rider(s) together from beginning until the end of a figure in the defined manner of riding and modality over the entire way of stretch. For the start and end of a figure, the body balance point is relevant.

1. If the figure is shown less than half of the way of stretch, devaluation of: **100%**
2. If the figure is shown less than 9/10 of the way of stretch, devaluation of: **50%**
3. If the figure is shown less than the total way of stretch, devaluation of: **10%**

4. At line figures (Artistic cycling team 4 and 6) the way of stretch will be measured at the wheel which is the nearest to the border of the riding-area.
5. At figures, where riders are riding next to each other, the way of stretch is to be measured according to the position of the outside-rider.
6. With an incorrect descending of the front wheel over more than 1 second, the way of stretch ends.
7. With falling or standing on the floor over more than 1 second the way of stretch ends.
8. With forbidden leaning and/or pushing of over more than 1 second the figure ends.
9. If a rider at a half eight or 8 is missing the middle point more than 75 centimetres, a devaluation occurs corresponding the missing way of stretch.

(text modified on 01.01.16)

8.1.040 Announced figures

Figures which are announced from outside the riding-area have to be devalued: **100%**

(text modified on 01.01.16)

8.1.041 End of performance

All figures of a programme have to be performed within the maximum time. After the maximum time has elapsed the missing way of stretch of the corresponding figure(s) has to be devalued.
The performance ends with finishing the last figure.

(text modified on 01.01.16)

8.1.042 End of evaluation

Regulations concerning the end of evaluation see under **8.2.009** and **8.3.043** (descend from bicycle).

(article introduced on 01.01.16)

§ 9 Judgement of difficulty valid for single and pair

8.1.043 Position of leg(s)

1. Stretched legs: Deviations of stretched knees (that means straight line) of more than 20° have to be devalued: **100%**
2. Bendstands and backstand: Deviations of the free leg more than 20° downwards in comparison with the described straight line downwards have to be devalued: **100%**
3. Bendstands and backstand: the foot of the free leg is lower than the supporting leg, it has to be devalued: **100%**
4. Scales: Deviations of the described straight line from more than 10° have to be devalued: **100%**
5. L-shape holds and all other figures with a mandatory horizontally, stretched position of the leg(s):
 - a) Deviations of the position of the legs downwards in comparison with the described position have to be devalued: **100%**

- b) Deviations of the position of the legs more than 20° upwards in comparison with the described position have to be devalued: **100%**
- 6. Straddles
 - a) Deviations of the position of the legs downwards in comparison with the described position have to be devalued: **100%**
 - b) Deviations of the position of the legs more than 20° upwards in comparison with the described position have to be devalued: **100%**
 - c) The angle of the straddle (“opening angle” of the legs) must have a minimum of 70°. Deviations have to be devalued: **100%**

(text modified on 01.01.16)

8.1.044 Passages

- 1. During a passage it is not allowed – according to preliminary notes and tables of figures - to stay (show) longer than 1 second in a position which is a known figure. Deviations have to be devalued: **50%**
- 2. During passages it is not allowed to stay (show) longer, in a position which is an unknown figure (according to preliminary notes and tables of figures) than a way of stretch of 2 metres. Deviations have to be devalued: **50%**

(text modified on 01.01.16)

8.1.045 Mautejump

- 1. If the rider does not reach the handlebar with his feet or only with one foot while performing the Mautejump. Devaluation: **100%**
- 2. If the rider reaches the handlebar with his feet while performing the Mautejump, but can't stand. Devaluation: **50%**
- 3. If the two metres or parts of it are missing. Devaluation: **10%**

(article introduced on 01.01.16)

8.1.046 Final figures

- 1. If a final figure, in which the rider has to pass (jump over) the handlebar, will be interrupted before the rider has passed the handlebar. Devaluation: **100%**
- 2. If the figure will be interrupted after the rider has passed the handlebar, but before the rider stands on the riding-area, in front of the bicycle. Devaluation: **50%**
- 3. If a final figure, in which the rider has to pass (jump over) the saddle, will be interrupted before the rider has passed the saddle. Devaluation: **100%**
- 4. If the figure will be interrupted after the rider has passed the saddle, but before the rider stands on the riding-area, behind the bicycle. Devaluation: **50%**
- 5. If the squat from side pedal to side pedal will be interrupted before the rider has passed the frame with his feet. Devaluation: **100%**
- 6. If at a handlebar straddle the legs are not in the straddle position above the handle-bar or the rider does not release the hands from the handlebar during the figure. Devaluation: **100%**
- 7. If at a straddlejump the legs are not stretched or one or both hands do not touch the feet. Devaluation: **100%**

8. If at straddles or straddlejumps the angle of the straddle (opening angle of the legs) is less than 70°. Devaluation: **100%**
9. Stretchjumps must be performed with stretched and closed legs. At the highest (top) position of the jump the arms have to be stretched upwards (vertical). If not, devaluation: **100%**
10. If at a handstandloop the handstand will not performed above the handlebars with stretched arms and stretched and closed legs/feet (a stop is not required). Devaluation: **100%**
11. If a twist is not performed over the total described body turn, the missing way of stretch will be devalued.
12. If at the end of a final figure the rider is standing on the riding area, but the bicycle can not be held. Devaluation: **10%**
13. If a somersault is performed with less than a half turn of the body. Devaluation: **100%**
14. Somersault: If the rider, after a correct full body turn, does not reach a stand on the riding-area. Devaluation: **50%**

(text modified on 01.01.16)

§ 10 Judgement of difficulty valid for pair

8.1.047 Single rings
Single rings may not be performed rounding the partner. Deviations have to be devalued: **50%**

8.1.048 Figures with obligation to perform in the middle circle
If figures which are to be performed with a grip connection above the inner circle (50 cm) are executed outside the middle circle (4 metres) are to be devalued: **50%**
The centre of the figure is decisive.

(text modified on 01.01.16)

8.1.049 Passages / jumps out of regular seat
Passages and jumps out of regular seat on two bicycles which are not performed simultaneously; one rider starts with a passage/jump out of regular seat after the partner already has reached the end position of that passage/jump out of regular seat, are to be devalued: **50%**

(text modified on 01.01.12; 01.01.16)

8.1.050 Turns on the spot

1. Pedalling during turning from one or more riders more than ¼ crankturn, a devaluation occurs corresponding the missing way of stretch.
2. Turns on the spot have to be performed by each rider on an own spot with a maximum diametre of 50 cm. Deviations have to be devalued corresponding the missing way of stretch.
3. If the required standing after the turns on the spot is missing, it has to be devalued: **10%**

(text modified on 01.01.12; 01.01.16)

- 8.1.051** Mautejump and fronthandlebarstand turn
1. The second rider has to start performing the Mautejump before the first rider has finished the described 2 metres way of stretch after the Mautejump otherwise devaluation: **50%**
 2. The second rider has to start performing the fronthandlebarstand turn before the first rider has finished the described 2 metres way of stretch after the fronthandlebarstand turn otherwise devaluation: **50%**

(text modified on 01.01.16)

- 8.1.052** Somersault
- The second rider is required to jump before the first rider is standing on the riding-area. If not devaluation: **50%**

(text modified on 01.01.16)

- 8.1.053** Grip connection at end of figure
- If the grip connection as described, at the end of the figure (exception turns on the spot) is not performed while riding, devaluation: **10%**

(text modified on 01.01.16)

§ 11 Judgement of difficulty valid for artistic cycling team 4 and 6

- 8.1.054** Simultaneous performance of figures
- If a figure will not be performed simultaneously always and solely a devaluation of difficulty has to be made.
1. If the connection and disconnection process of the grips at the start and/or the end of the figure and if described during the figure are not performed simultaneously, this has to be devalued: **10%**
 2. If the last grip connection will be connected, after the first rider already has performed 2 metres, devaluation: **50%**
 3. If the grip connection(s) as described (at the start and/or at the end or else during the figure) is not performed while the bicycle is riding (preliminary notes and explanations of figures), devaluation: **10%**

(text modified on 01.01.16)

- 8.1.055** Figures with obligation to perform in the middle circle
1. If ~~parts of figures which are to be performed in the middle circle with a grip connection above the inner circle (50 cm)~~ are executed outside the middle circle (4 metres) they ~~must have to~~ be devalued: **50%**. The centre of the figure is decisive.
 2. If the described inside individual / turn on of figures, which have to be performed inside the middle circle, did not start outside the middle circle, devaluation: **100%**
 3. If the described outside individual of figures, which have to be performed inside the middle circle, is not leading out of the middle circle, devaluation: **10%**

(text modified on 01.01.16; 01.01.17)

- 8.1.056** Turns on the spot
1. Pedalling during turning from one or more riders more than $\frac{1}{4}$ crankturn, a devaluation occurs corresponding the missing way of stretch.
 2. Turns on the spot have to be performed by each rider on an own spot with a maximum diametre of 50 cm. Deviations have to be devalued corresponding the missing way of stretch.
 3. If the required standing after the turns on the spot is missing, it has to be devalued: **10%**

(text modified on 01.01.12; 01.01.16)

- 8.1.057** Turn on / in- and outside individual
1. If the required 2 metres of inside individual / turn on have not been performed, then the figure didn't start, devaluation: **100%**
 2. If the required 2 metres of inside individual / turn on have not been performed completely, devaluation: **10%**
 3. If the required 2 metres of outside individual have not been performed completely, devaluation: **10%**
 4. If the required 2 metres of inside individual / turn on and of outside individual have not been performed completely, devaluation **10%**
 5. If the ~~turn on the spot during~~ turn on will not be performed within a diametre of 50 cm, devaluation: **100%**
 6. If during turn on the maximum allowed way of stretch of 2 metres between turn on ~~the spot~~ and grip connection will be exceeded, devaluation: **10%**

(article introduced on 01.01.16; text modified on 01.01.17)

- 8.1.058** Stars
1. If in the required endposition of the figure the headtubes of the bicycle resp. the back wheels (star outside resp. star opposite direction) are not showing to the inner circle, a positional error occurs
 - a) more than a half of the riders, devaluation: **100%**
 - b) a maximum of a half of the riders, devaluation: **50%**
 2. If in the required endposition of the figure the required grip connection doesn't occur from all riders, devaluation: **100%**
 3. Riding in grip connection to the endposition of the figure, it has to be devalued: **100%**
 4. If the required standing after the turns on the spot is missing, it has to be devalued: **10%**

(article introduced on 01.01.16)

§ 12 Judgement of performance

- 8.1.059** Decisive for the judgement of performance are:
The preliminary notes, the guidelines for single, pair, artistic cycling team 4 and artistic cycling team 6, the explanations in the tables of figures and following regulations of the judgement of performance which have to be used when noted mistakes occur during the performance of the riders.
Exceptions are the mistake-group 1f-1h (valid from entering until leaving the riding-area) and the mistake-group 2 and 3 (valid from entering the riding-area until the end of the maximum time).

Touching the floor or standing on the floor which is part of the riders presentation has not to be devalued (are allowed).

(text modified on 01.01.16)

- 8.1.060** Mistake-groups 1a and 1b
Mistakes of these mistake-groups are to be devalued as they happen.
- A. Slight, short, arising shortly:
mistake sign x (X) devaluation value: 0.2 point
 - B. Fierce, permanently, arising longer:
mistake sign ~ (wave) devaluation value: 0.5 point
- 8.1.061** Mistake-groups 1c, 1d, 1e, 1f, 1g and 1h
A. Mistakes of these mistake-groups are to be devalued by:
mistake sign ~ (wave) devaluation value: 0.5 point
- 8.1.062** Mistake-group 2
A. Mistakes of this mistake group are to be devalued by:
mistake sign | (line) devaluation value: 1.0 point
- 8.1.063** Mistake-group 3
A. Mistakes of this mistake-group are to be devalued by:
mistake sign O (circle) devaluation value: 2.0 points
- 8.1.064** Remark on mistake-groups 1 and 2
If mistakes described in mistake-groups 1 and 2 are directly followed by mistakes of mistake-group 3, only the devaluation of mistake-group 3 may be devalued.

Mistake-group 1

- 8.1.065** Mistake-group 1a (x, ~)
Devaluation per kind of mistake, per rider and figure only once:
1. Hands and/or arms not stretched, or having an incorrect position;
 2. Rowing or rotating movements of arms;
 3. Jerky pedalling;
 4. Incorrect posture of the upper part of the body;
 5. Unsteadiness;
 6. Wandering during 50 cm spinings;
 7. Post motion of bicycle, correction step, or hopping at final figures;
 8. ~~Incorrect position of legs, less than 20° Legs not stretched (less than 20°) or having an incorrect position;~~
 9. ~~Knee not stretched, less than 20°~~
 10. Feet not stretched or having an incorrect position.

(text modified on 01.01.16; 01.01.17)

- 8.1.066** Mistake-group 1b (x, ~)
Devaluation per kind of mistake and figure only once:
1. Different sizes of circles during half eight and all kinds of eight and opposite single rings;
 2. Displacement of circles during a half eight and all kinds of an eight;
 3. Non-simultaneous execution of figures;
 4. Incorrect direction;
 5. Unequal distances;

6. Correction movings within grip connections during standing after turns on the spot and stars.

(text modified on 01.01.16)

8.1.067 Mistake-group 1c (~)

Devaluation per kind of mistake and figure only once:

1. Only once or not crossing the inner circle (= 50 cm) during an eight ~~with a deviation of less than 75 cm from the middle point~~;
2. Not crossing the inner circle during a half eight ~~with a deviation of less than 75 cm from the middle point~~;
3. Wrong positions on the riding-area;
4. Deviation of the constant distance to the inner circle during circles or half circles (only single and pair) from more than 2 metres.

(text modified on 01.01.16; 01.01.17)

8.1.068 Mistake-group 1d (~)

Devaluation per kind of mistake per rider only once:

1. Incorrect changing of the bicycle(s) (only pair);
2. Incorrect descending from the bicycle.

(text modified on 01.01.16)

8.1.069 Mistake-group 1e (~)

Devaluation of this kind of mistake as often as it appear; only between the figures.

1. Crossing the outside marking of the riding-area.

(text modified on 01.01.16)

8.1.070 Mistake-group 1f (~) (valid for single and pair)

Devaluation when this kind of mistake occurs, before the first and between the figures, only once:

1. Unsteadiness.

(text modified on 01.01.16)

8.1.071 Mistake-group 1g (~) (valid for team 4 and team 6)

Devaluation when this kind of mistake occurs, before the first and between the figures, only once:

1. Unsteadiness;
2. Hands and/or arms not stretched, or have a wrong position ~~during between~~ free-hand figures;
3. Non-synchronous grapple and release (by hand) of the bicycle;
4. Non-synchronous lowering and rising of the frontwheel during raiser figures.

(text modified on 01.01.16; 01.01.17)

8.1.072 Mistake-group 1h (~)

bis

Devaluation per kind of mistake per rider only once:

1. Incorrect presentation of the rider(s) before the start of the ~~maximal maximum~~ time;

2. Incorrect descending from the bicycle after the end of the **maximal maximum** time;
3. Incorrect presentation of the rider(s) after the end of the **maximal maximum** time.

(text modified on 01.01.16; 01.01.17)

Mistake-group 2

8.1.073 Mistake-group 2 (I)

bis

Devaluation of mistakes per rider and kind of mistake, as often they arise (also before the first and between the figures):

1. Grab and release the handlebar, bicycle or team members with, one or two hands, during free-hand figures;
2. Lowering and raising of the front wheel during raiser figures or raiser passages;
3. Touching the floor or standing on the riding-area, each foot (**maximal maximum** 1 second);
4. Leaning on/pushing of, resting on handlebar, frame or saddle with either leg(s) or foot/feet during squats and turning jumps;
5. Catching (with parts of body) the frame after finishing a turning jump before seizing the pedals;
6. Rider is standing, but the bicycle falls on the riding-area (only final figures);
7. Not allowed touching of the partner (only during the performance of a figure).

(text modified on 01.01.16; 01.01.17)

Mistake-group 3

8.1.074 Mistake-group 3 (O)

bis

Devaluation of mistakes per rider and kind of mistake, as often they arise, also before the first and between the figures:

1. Falling; from entering the riding-area until the end of the **maximal maximum** time;
2. Standing on the floor (more than 1 second) from start of the **maximal maximum** time until the end of the **maximal maximum** time;
3. Holding on objects not belonging to the team;
4. Persons entering the riding-area in order to hand over the bicycle(s) during the change of bicycle(s) at pair artistic cycling;
5. Rider ends not standing on the riding-area (final figures);
6. Parking or leaving the bicycle(s) outside the coaching zone in pair artistic cycling (a bicycle is called left or parked from the moment the riders have started the next figure).

(text modified on 01.01.16; 01.01.17)

Chapter II GUIDELINES FOR SINGLE AND PAIR ARTISTIC CYCLING

§ 1 General guidelines on single and pair riding programmes

- 8.2.001** Leaving bicycles
During the performance of the programme riders are not allowed to leave their bicycle.
The only exception is in pair artistic cycling when the riders change from two bicycles to one, or from one bicycle to two. There is only one change allowed during a performance.
(text modified on 01.01.16)
- 8.2.002** Start of programme
As soon as the rider(s) enter the riding-area the evaluation will start. The riders present themselves on the riding-area standing on the surface.
The programme must start with the clear call "START"; being on the bicycle without touching the riding-area. At the call "START" the time will be taken.
(text modified on 01.01.16)
- 8.2.003** Execution of figures (body posture)
During the execution of the figures a correct body position is required in the sense of sportmenlike artistic cycling which may not be changed during the whole performance of a figure. Exceptions are the figures where a changing of the body position is necessary.
(text modified on 01.01.16)
- 8.2.004** Commands of performance
Riders are only allowed to give commands of performance during their own performance.
(text modified on 01.01.16)
- 8.2.005** Announcing figures
During all disciplines announcing and/or showing the figures by outsiders is not allowed.
(text modified on 01.01.16)
- 8.2.006** Tactical figures (T)
For figures which are described as tactical in the tables of figures it is allowed to extend these figures, during the performance of this figure as described.
(text modified on 01.01.16)
- 8.2.007** Interruption of evaluation
The rider/coach will announce a defect of her/his bicycle, an injury or illness by lifting/raising the arm or/and by a clear call "STOP".
(text modified on 01.01.16)

- 8.2.008** Final figures
Final figures can only be performed as the last figure before the change of bicycles in pair artistic cycling or as the last figure of the programme.
The riders have to end the final figure standing on the riding-area, holding the bike with one hand, while stretching the other arm sideways (horizontally).

(text modified on 01.01.16)

- 8.2.009** ~~Descent from bicycle~~ ~~End-of-evaluation~~
At the end of the performance all riders have to descend from their bicycle and present themselves, while standing on the riding-area towards the audience. ~~The evaluation ends after a correct dismounting of the bicycle, a presentation towards the audience while standing on the riding-ares. Hereby~~ The evaluation ends at this moment (even after the ~~maximal~~ maximum time).

(text modified on 01.01.16; 01.01.17)

- 8.2.010** Deviations
If deviations in these regulations occur between the drawing and the applicable text, the text will prevail in such a case.

§ 2 General guidelines for the pair riding programme

- 8.2.011** Simultaneous execution of figures
All the figures on two bicycles must be performed simultaneously.

(text modified on 01.01.16)

- 8.2.012** Grip connections
When in the explanations of figures "single" is not prescribed for a figure on two bicycles or in the guidelines just a touch of hands is being asked for, the figure must be shown totally or partially in grip connection.
The following kinds of grip connections are allowed:
- hand-in-hand grip,
 - double-arm grip,
 - double-shoulder grip.

(text modified on 01.01.16)

- 8.2.013** Changing bicycles
~~The descent from the bicycle has to be performed correctly.~~
~~When changing from two to one or from one to two bicycles both riders have to dismount correctly and start their performance again without assistance.~~
The hand over / hand in change of the bicycle has to be executed ~~at~~ within the coaching zone.
The ascent on the bicycle has to be performed without assistance.

(text modified on 01.01.16; 01.01.17)

§ 3 Guidelines for performance on the riding-area single and pair

8.2.014 All figures have to be performed within the borders of the riding-area. The distance ridden at the outside of the riding-area has to be repeated inside. All figures have to be executed on the riding-area, corresponding the names of the figures and applicable way of stretch, as described below.

(text modified on 01.01.16)

8.2.015 Figures which may be shown anywhere on the riding-area
 Handlebar spinnings, handlebarstand turns, stillstands, turns, squats, jumps, spinnings, turns on the spot, single rings out of forehead-line, passages and final figures.

(text modified on 01.01.16)

Performance of figures on the riding-area

8.2.016 Circle (C.)
 Only the distance ridden outside the middle circle (4 metres) is valid for the evaluation. During the execution of a circle the distance to the centre of the riding-area must stay the same for the total way of stretch.
 During circles which have to be executed separately (in pair) the distance between the two riders must be identical for the total way of stretch. A circle ends after at least one total turn (360°) around the middle circle.

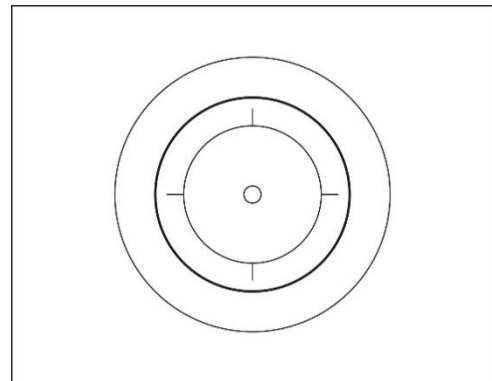

(text modified on 01.01.16)

8.2.017 Half circle (HC.)
 Only the distance ridden outside the middle circle (4 metres) is valid for the evaluation. During the execution of a half circle the distance to the centre of the riding-area must stay the same for the total way of stretch.
 During circles which have to be executed separately (in pair) the distance between the two riders must stay the same for the total way of stretch. A half circle ends after at least a half turn (180°) around the middle circle.

(text modified on 01.01.16)

8.2.018 Eight (8)

An eight is formed by two circles. Both circles must have the same diameter with a minimum of 4 metres. The inner-circle (50 cm) is to be crossed twice during the execution of an 8. The circles have to be executed each, at an opposite located half of the riding-area.

The riding-area is divided, imaginary, in 2 halves by a line through the middle of the riding-area.

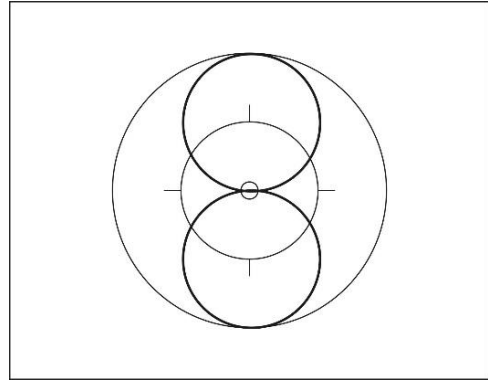

8.2.019 Half eight (S)

A half eight is formed by two half circles. Both half circles must have the same diameter with a minimum of 4 metres. The inner circle (50 cm) is to be crossed once during the execution of a S. The sequence of the figure starts at the longitudinal or transverse axis of the riding-area. The half circles have to be executed at two, across from each other, placed quarters of the riding-area (one half circle at each quarter).

The riding-area is divided, imaginary, in 4 quarters by the longitudinal and transverse axis.

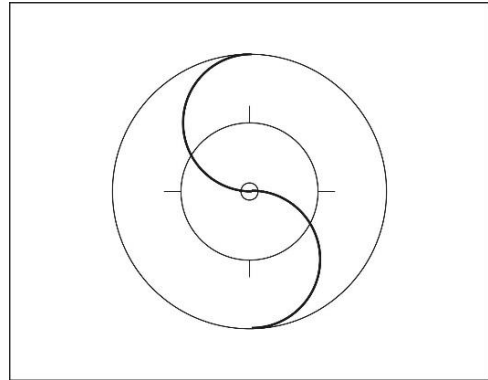

(text modified on 01.01.16)

8.2.020 Counter eight (Count. 8)

Each rider executes an eight in contrary to the partner. The sequence of the figure starts at the centre of the riding-area with a touch of hands (except handstand) of the riders. The figure ends after completing the total way of stretch with a touch of hands (except handstand) of the riders again at the centre of the riding-area.

(text modified on 01.01.16)

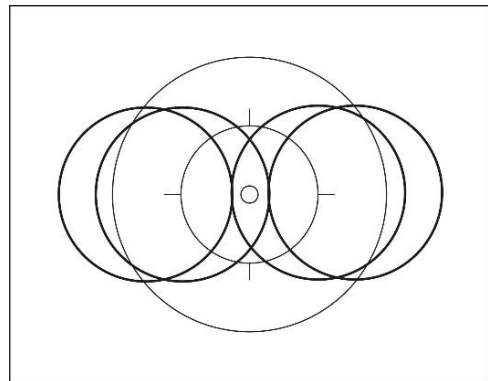

8.2.021 Counter circle (Count. C)

Each rider executes each on a separate half of the riding-area a complete circle with a minimum diameter of 4 metres around a point. The two points are lying with the same distance to the inner circle on the longitudinal axis.

The riding-area is divided, imaginary, by the transverse axis.

The sequence of the figure starts and ends at the centre of the riding-area with a touch of hands of the riders.

The way of stretch which is executed at the handlebar-turn belongs to the content of the total way of stretch of the counter circle.

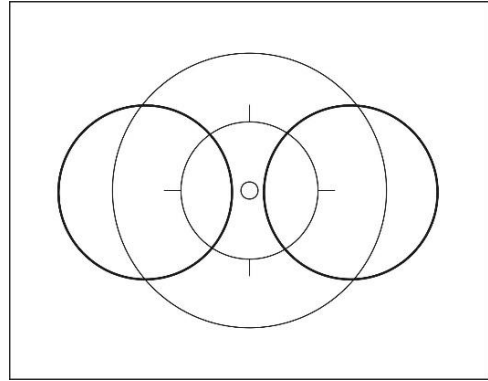

(text modified on 01.01.16)

8.2.022 Turn on the spot

After detaching from grip connection, in the respective kind of raiser, each partner turns on the spot without pedalling. At the end of the last turn the grip connection is required. After that the grip connection at the end of the figure is completed the riders have to stand without moving. During releasing and closing the grip connection, the riders are required to stand still.

(text modified on 01.01.16)

8.2.023 Mill

Connected through hand-in-hand grip with their left (or right) hands, the partners show the respective figure in the middle of the riding-area. A way of stretch with a minimum of one complete circle (360°) is to be performed.

At performing a mill with single-rings (s.r.) or mill-spinnings (mill. spin.) the partners have to show a grip connection at the middle of riding-area at the start of the figure. After this grip connection the riders release their hands; execute the single-rings or mill-spinnings; and grab back to the hand-in-hand grip connection in the middle of the riding-area.

Riders are not allowed to stand still with their bikes during releasing and closing the grip connection at the beginning and the end of the figure (bicycles must move during these actions).

(text modified on 01.01.16)

8.2.024 Forehead-line

Partners are riding/standing, side by side, in the same direction, performing the respective figure. They are connected to each other by a grip connection.

(text modified on 01.01.16)

8.2.025 Single rings (s.r.)

A single ring is a small circle performed ~~at~~ around a spot on the riding-area. During the performance of this figure this spot is the centre of this figure. A way of stretch with a minimum of one complete circle (360°) has to be performed.

The release of the start-position and the grapple into the end position are to be performed while moving the bicycles (stillstand is not allowed during these actions).

The figure ends at the moment that the end-position is showed.

For following figures the partners are obliged to touch hands, before and after single rings, indicating the start and the end of the figure: Saddle-handlebarstand, Handlebarstand and Saddlestand.

During the performance of single rings in mills (middle of the riding-area) the riders have to pass the middle circle (4 metres).

(text modified on 01.01.16; 01.01.17)

8.2.026 50-cm-Spinnings (spin.)

bis

Spinnings have to be performed on a spot with a ~~maximal~~ maximum diametre of 50 cm, according to the kind of raiser in the context of a figure. The spinnings start being judged when the diametre has been achieved by all riders (rear wheel of the bicycle spin within the diametre of 50 cm). At least 3 complete, successive, spinnings, within the mentioned diametre of 50 cm, have to be performed by all riders.

When spinnings are performed as part of a figure with described grip connection at the beginning and/or at the end of the figure the release and grapple of the grip connection must be performed with a moving bike (stillstand not allowed). It is allowed to change the riding-direction at the end of the figure.

(text modified on 01.01.16; 01.01.17)

§ 4 Guidelines for performance on bicycle single and pair

8.2.027 Position of the arms

Figures which do not have the word frh. in the text, the riders have to be connected with one hand to a rider with a grip connection. The other hand is connected to the handlebar (or frh.).

All riders have to show the identical way of positioning the arms. When riders are not connected to a partner and are connected to the handlebar with a hand, the other hand/arm has to be stretched sideways. Possible deviations are described in the explanations of figures.

(text modified on 01.01.16)

8.2.028 Position of arms and legs (stretching etc.)

If arm(s) is mentioned in the text this means that this is related to the elbow, wrist and finger.

If in the text is mentioned leg(s) this means that this is related to the knee and ankle.

(text modified 01.01.16)

8.2.029 Free-hand (frh.)

If free-hand (frh.) is written in the context of a figure, neither the handlebar, the bicycle(s), nor the partners may be touched during the total way of stretch of the figure. Exceptions are described at the explanations of figures.

Arms which are not connected by a grip connection are to be stretched, horizontally, sideways by an angle of 90° to 110° towards the body (see drawing).

(text modified on 01.01.16)

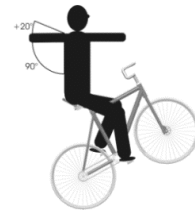

8.2.030 Both wheels on floor

Except figures with the text “raiser” all figures are to be performed with both wheels on the floor during the total way of stretch of the figure.

Exceptions are described in the explanations of figures.

(text modified on 01.01.16)



8.2.031 Raiser

If “raiser” is written in the context of a figure, the total way of stretch of the figure has to be performed in the described raiser-position.

Only the rear wheel should touch the floor.

(text modified on 01.01.16)



8.2.032 Forward

All of the figures are to be performed in forward direction if they are not marked as backward. Exceptions are described in the explanations of figures.

At all figures with both wheels on the floor; turns, squats and jumps forward is determined by the bicycle. At all raiser figures the direction of the riders face is decisive for the forward direction.

(text modified on 01.01.16)



8.2.033 Backward (bw.)

When figures are marked with “backward” they have to be performed during the total way of stretch of the figure in the backward direction. Exceptions are described in the explanations of figures.

At all figures with both wheels on the floor; turns, squats and jumps the backward motion is determined by the movement of the rolling bicycle. At all raiser figures the direction of the riders face is decisive for the forward and backward direction.

(text modified on 01.01.16)



- 8.2.034** Bendstands and stand bent on pin
At all bendstands and at stand bent on pin head, body, leg and foot show a straight line.
The foot of the free leg has to be at least on the same level like the supporting leg.
(text modified on 01.01.16)
- 8.2.035** Saddle handlebar-, handlebar- and saddlestands
These figures will have to be performed in an upright, free-hand position, with sideways stretched arms and hands.
(text modified on 01.01.16)
- 8.2.036** Straddles
Straddles have to be performed with horizontally stretched legs. At straddles or straddlejumps the angle of the straddle (opening angle of the legs) has to have a minimum opening of 70°.
(text modified on 01.01.16)
- 8.2.037** Squats and jumps
All these figures have to be performed without bracing, pushing off and leaning onto the handlebars, frame or saddle with legs or feet.
(text modified on 01.01.16)
- 8.2.038** Stillstands
Stillstands have to be performed at least 3 seconds.
(text modified on 01.01.16)
- 8.2.039** Passages (P.)
All passages can be performed in any spot of the riding-area, without touching the floor and without any other assistance. The figure has to be shown from the starting position until the endposition without taking another figure position. If the described endposition is a raiser-position, the following figure must be shown in the same kind of raiser.
The start and the end of the passage has to be shown according the description of the start- and endposition in the explanations of figures.
Passages in pair artistic cycling, on two bicycles, must be performed in grip connection (except the passage backhang raiser headtube reverse / standraiser).
(text modified on 01.01.16)
- 8.2.040** Stands and shoulderseats on one bicycle
All the pin-, saddle handlebar-, handlebar-, saddle-, shoulderstands and shoulderseats must be performed with horizontally, sideways, stretched arms (except ring-grip), without support from the partner and in an upright position. For the figure Saddle handlebarstand/Saddle handlebarstand, it is not required to have sideways stretched arms. During this figure it is allowed to touch or hold the partner.

For the figure Raiser regular seat/Stand on pins, it is not required to have sideways stretched arms for the position Stand on pins. It is allowed to touch or hold the partner which is in the raiser-position.

(text modified on 01.01.16)

- 8.2.041** Headstands, shoulderstands and handstands on one bicycle
Figures with these positions have to be performed without support. It is not allowed to touch or hold the partner during the execution of these figures.

(text modified on 01.01.16)

- 8.2.042** Counterwise
If the term "counterwise" appears in the text this means the same position is possible with the opposite foot or leg, with opposite pedal and/or opposite rear- or frontpin.

Chapter III GUIDELINES ARTISTIC CYCLING TEAM 4 AND 6

- 8.3.001** General guidelines to riding programmes artistic cycling team 4 and 6
All figures have to be performed on the riding-area.
The distance ridden outside of the riding-area has to be repeated inside.
All figures have to be performed according the explanations in the tables of figures.
It is not allowed to leave the bicycles during the riding-programme.

(text modified on 01.01.16)

- 8.3.002** Deviations
If deviations in these regulations occur comparing the drawing and the belonging text, in that case the text will be leading.

- 8.3.003** Execution of figures (body posture)
During the execution of the figures a correct body position is required in the sense of sportmenlike artistic cycling which may not be changed during the whole performance of a figure. Exceptions are the figures where a changing of the body position is necessary.

(text modified on 01.01.16)

- 8.3.004** Commands of performance
It is only allowed that riders can give commands of performance during their own performance.

(text modified on 01.01.16)

- 8.3.005** Announcing figures
During all disciplines announcing and/or showing the figures by outsiders is not allowed.

(text modified on 01.01.16)

- 8.3.006** Interruption of evaluation
The rider/coach will announce a defect of her/his bicycle, an injury or illness by lifting/raising the arm or/and by a clear call "STOP".

(text modified on 01.01.16)

- 8.3.007** Start of programme
As soon as rider(s) enter the riding-area the evaluation will start. The riders present themselves on the riding-area standing on the surface. The programme must start with a clear call "START"; being on the bicycle without touching the riding-area. At the call "START" the ~~maximal~~ maximum time will start.

(text modified on 01.01.16; 01.01.17)

- 8.3.008** Tactical figures (T)
For figures which are in the tables of figures described as "tactical" it is allowed to extend these figures as described, during the performance of this figure.

(text modified on 01.01.16)

- 8.3.009** Final figures
Final figures only can be performed as last figure and are part of the riding-programme. The riders have to end the final figure standing on the riding-area, holding the bike with one hand, while stretching the other arm sideways (horizontally).

(text modified on 01.01.16)

- 8.3.010** Both wheels on floor
Except figures with the text "raiser" all figures are to be performed with both wheels on the floor during the total way of stretch of the figure. Exceptions are described in the explanations of figures.
Figures with both wheels on the floor means: The rider sits on the saddle, each foot is on a different pedal and the front- and rear wheel have contact to the floor.



(text modified on 01.01.16)

- 8.3.011** Raiser
If "raiser" is written in the context of a figure, the total way of stretch of the figure has to be performed in the described raiser-position. The rider sits on the saddle, each foot is on a different pedal and only the rear wheel should touch the floor.



(text modified on 01.01.16)

- 8.3.012** Forward
All the figures have to be performed forward during the total way of stretch, if they are not marked as backward. Exceptions are described in the explanations of figures. The forward direction has to be executed as shown in the drawing.



(text modified on 01.01.16)

- 8.3.013** Backward (bw.)
When figures are marked as "backward" they have to be performed backward during the total way of stretch. Exceptions are described in the explanations of figures. The backward direction has to be executed as shown in the drawing.



(text modified on 01.01.16)

8.3.014 Surroundings

If “forward” is written in the context of figures with surroundings, the surrounding has to be performed in anticlockwise direction. If “backward” is written in the context of figures with surroundings, the surrounding has to be performed in clockwise direction. Exceptions are described in the explanations of figures.

8.3.015 Position of the arms

In figures which do not have free-hand (frh.) in the context of the figure, the riders have to grab with their not connected hands the handlebar and/or to ride free-hand.



All riders have to show an identical way of positioning the arms. If riders are not connected to a partner and are connected to the handlebar with one hand, the other hand/arm has to be stretched sideways. Possible deviations are described in the explanations of figures.

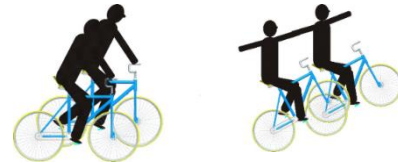

(text modified on 01.01.16)

8.3.016 Grip connections

Following kinds of grip connections are allowed: Hand-in-hand grip, double-arm grip, shoulder- or double-shoulder grip. Possible deviations are described in the explanations of figures. All other grip connections are not allowed.

(text modified on 01.01.16)

8.3.017 Free-hand (frh.)

If free-hand (frh.) is written in the explanations of a figure, the whole way of stretch has to be shown free-hand. A free-hand way of stretch means, that neither the handlebar, the bicycle(s), nor the partners are allowed to be touched during the total way of stretch of a figure. Possible exceptions are described in the explanations of figures.

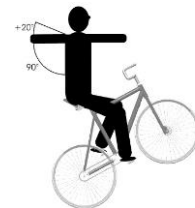

Not connected arms/hands (except doors and surroundings) have to be stretched horizontally and sideways. All free-hand positions have to be executed with sideways stretched arms and an angle of 90° bis 110°.

(text modified on 01.01.16)

Presentation of figures with inside motions, turn on and outside motions

- 8.3.018** Figures with inside and outside motions
If in the context of figures is mentioned “frh. inside individual” only the figure itself has to be performed free-hand. If in the context of the figure is mentioned inside individual frh. respectively turn on frh. the **inside individual 2-metres**/turn on at the start of the figure and the figure itself has to be performed free-hand. At figures, which are required to perform within the middle circle (4 metres), the inside individual/turn on motion has to start outside of the middle circle. The outside individual motion has to end outside of the middle circle.

(text modified on 01.01.16; 01.01.17)

- 8.3.019** Inside individual (inside indiv.)
If in the context of the figures is mentioned “inside individual” all riders have to perform at least an individual (without grip-connection) distance of 2 metres (inside motion) before they execute the belonging figure according the explanations. The mentioned individual distance, the following grip-connection and the belonging figure have to be performed simultaneous without stops. After the grip-connection the figure has to be performed over the total way of stretch according the explanations. The riders are free of choice because of executing the inside individual motion and the figure; free-hand, with one or two hands at the handlebar, but they are required to use all the same kind of performance.

(text modified on 01.01.16)

- 8.3.020** Free-hand inside individual (frh. inside indiv.)
Free-hand inside individual means that all riders have to perform at least 2 metres individual and without grip connection. The figure followed by the inside motion has to be performed free-hand. After the inside individual the riders have to grab simultaneously and in motion to the figure described in the explanations of figures. The figure has to be shown free-hand. It's the choice of the rider, if they perform the inside individual with one or both hands on the handlebar, but the execution of all riders have to be identical.

(text modified on 01.01.16)

- 8.3.021** Inside individual free-hand (frh.) / turn on frh.
1. Inside individual free-hand means that the inside motion and the corresponding figure has to be executed free-hand. The individual inside motion has to be performed by all riders at least 2 metres individual (without grip-connection) free-hand before they execute the corresponding figure, free-hand, according the explanations. The mentioned individual distance, the following grip-connection and the corresponding figure have to be performed simultaneous and in motion.

2. Turn on frh. means that the turn on motion and the corresponding figure has to be executed free-hand. The turn on motion has to be performed by all riders at least 2 metres individual (without grip-connection) free-hand, than a turn on with a diametre of max. 50 cm and afterwards within a distance of 2 metres before they execute the corresponding figure, free-hand, according the explanations. The mentioned individual distance, the following grip-connection and the corresponding figure have to be performed simultaneous and in motion.

(text modified on 01.01.16)

8.3.022 In- and outside individual (in- and outside indiv.)

If in the context of figures is mentioned "in- and outside individual" all riders have to perform at least an individual (without grip-connection) distance of 2 metres (inside motion) before they execute the corresponding figure according the explanations. After the corresponding figure they have to perform again an individual (without grip connection) distance of 2 metres (outside motion). The mentioned inside motion, the following grip connection, the corresponding figure and the outside motion have to be performed simultaneous and in motion. The part of the figure between the in- and outside motions has to be performed over the total way of stretch according the explanations. The riders are free because of executing the inside individual motion, the figure and the outside motion; free-hand, with one or two hands at the handlebar, but it has to be identical.

8.3.023 Free-hand in- and outside individual (frh. in- and outside indiv.)

Free-hand in- and outside individual means that the figure followed by the inside motion has to be performed free-hand. The inside and outside motion of the riders can be performed; free-hand, with one or two hands at the handlebar, according the choice of the riders, but it has to be identical. All riders have to perform the individual inside motion individual (without grip connection) 2 metres before they execute the corresponding figure, free-hand, according the explanations. After the corresponding figure they have to perform again an individual (without grip connection) distance of at least 2 metres (outside motion). The mentioned inside motion, the following grip-connection, the corresponding figure and the outside motion have to be performed simultaneous and in motion.

8.3.024 In- and outside individual free-hand (in- and outside indiv. frh.) /

bis turn on and outside individual (turn on and outside indiv. frh.)

1. Inside individual free-hand means that the inside motion and the corresponding figure have to be executed free-hand. All riders have to perform the individual inside motion individual (without grip-connection) at least 2 metres free-hand before they execute the corresponding figure, free-hand, according the explanations. The mentioned individual distance, the following grip connection and the corresponding figure have to be performed simultaneous and in motion.

2. Turn on frh. means that the turn on motion and the corresponding figure have to be executed free-hand. All riders have to perform the turn on motion individual (without grip connection) at least 2 metres free-hand, then a turn on with a diameter of max. 50 cm and afterwards within a distance of 2 metres before they execute the corresponding figure, free-hand, according the explanations. The mentioned individual distance, the following grip connection and the corresponding figure have to be performed simultaneous and in motion.
3. Outside individual free-hand means that the outside motion after the belonging figure have to be executed free-hand. All riders have to perform the individual outside motion individual (without grip connection) at least 2 metres free-hand according the explanations. The mentioned individual distance, grip connection and the outside motion have to be performed simultaneous and in motion.

(text modified on 01.01.16)

8.3.025 Lowering and rising of the frontwheel

If riders, in advance of the first, or between figures obviously lower or rise the frontwheel, it has to occur simultaneously.

(text modified on 01.01.16)

8.3.026 Grab and release of the bicycle

If riders, in advance of the first or between figures obviously release or grab the bicycle, it has to occur simultaneously.

(text modified on 01.01.16)

8.3.027 Half circle (HC.)

Only the distance ridden outside the middle circle (4 metres) is valid for the evaluation. During the execution of a half circle the distance to the centre of the riding-area must stay the same for the total way of stretch.

A half circle ends after at least a half turn (180°) around the middle circle.

(article introduced on 01.01.16)

8.3.028 Circle (C.)

Only the distance ridden outside the middle-circle (4 metres) is valid for the evaluation. During the execution of a circle the distance to the centre of the riding-area must stay the same for the total way of stretch.

During circles which have to be executed separately the distance between the riders must be identical for the total way of stretch.

A circle ends after at least one total turn (360°) around the middle circle.

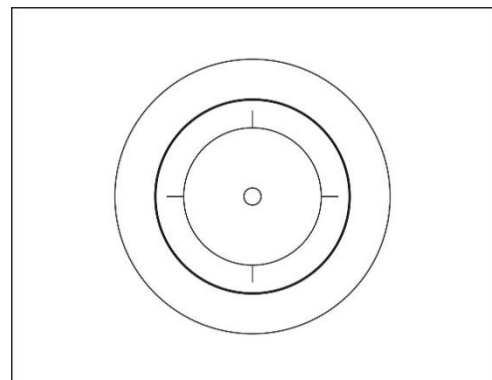

(article introduced on 01.01.16)

- 8.3.029** Single ring left (s.r.l.) / **single ring left through (s.r.l. through)**
1. A single ring left is performed with a way of stretch of a complete circle around a spot at the riding-area. In forward direction the surrounding direction is anti-clockwise. In backward direction, the surrounding direction is clockwise. A single ring ends after all riders have performed a complete circle and return to their starting position.
 2. **Single ring left through: execution similar to single ring left, except that the single rings of the two riding riders inside are overlapping.**

(article introduced on 01.01.16; text modified on 01.01.17)

- 8.3.030** Single ring right (s.r.r.)
- A single ring right is performed with a way of stretch of a complete circle around a spot at the riding-area. In forward direction the surrounding direction is clockwise. In backward direction, the surrounding direction is anti-clockwise. A single ring ends after that all riders have performed a complete circle and return to their starting position.

(article introduced on 01.01.16)

- 8.3.031** Half counter single ring (half count. s.r.)
- A half counter single ring consists of two half circles, around a spot (point) at the riding-area. Both half circles have to be performed in same size and uniform by all riders. One of the two half circles has to be performed clockwise; the other half circle has to be performed anti-clockwise. Before and after performing the change of direction the riders are required to show a minimum of 2 metres each in the respective direction.

(article introduced on 01.01.16)

- 8.3.032** Counter single ring (count. s.r.) / **counter single ring overlapping (count. s.r. overlapping)**
- Counter single ring:** A counter single ring consists of two circles, around a spot (point) at the riding-area. Both circles have to be performed in same size and uniform by all riders. One of the two circles has to be performed clockwise; the other circle **has** to be performed anti-clockwise. Before and after performing the change of direction the riders are required to show a minimum of 2 metres each in the respective direction.
- Counter single ring overlapping:** The way of stretch of the second circle overlaps with the first circle of the rider riding ahead.

(article introduced on 01.01.16; text modified on 01.01.17)

- 8.3.033** 2 connected single ring left (2 con. s.r.l.)
- A 2 connected single ring left is a surrounding around a common Point. Two riders are riding with closed grip connection and in same direction side by side. In direction forward, the surrounding direction is anti-clockwise. In direction backward, the surrounding direction is clockwise. The single ring is finished if they surrounded the point completely and return to their starting position.

(article introduced on 01.01.16)

8.3.034 2 connected single ring right (2 con. s.r.r.)

A 2 connected single ring right is a surrounding around a common Point. Two riders are riding with closed grip connection and in same direction side by side. In direction forward, the surrounding direction is clockwise. In direction backward, the surrounding direction is anti-clockwise. The single ring is finished if they surrounded the point completely and return to their starting position.

(article introduced on 01.01.16)

8.3.035 Half Eight (S)

A half eight consists of two half circles, each with a minimum diameter of 4 metres, each performed around a spot at the riding-area. Both half circles to be performed in same size and uniform by all riders. One of the two half circles has to be performed clockwise; the other half circle has to be performed anti-clockwise. The change of direction between the both half circles has to be performed within the inner circle. Before and after performing the change of direction the riders are required to show a minimum of 2 metres each in the respective direction. A half eight starts on the longitudinal or transverse axis and ends on the same axis.

(article introduced on 01.01.16)

8.3.036 Eight (8)

An eight consists of two circles, each with a minimum diameter of 4 metres, each performed around a spot at the riding-area. Both circles have to be performed in same size and uniform by all riders. One of the two circles has to be performed clockwise; the other circle has to be performed anti-clockwise. The change of direction between the both circles has to be performed within the inner circle. The inner circle has to be crossed twice during the execution of the figure. Before and after performing the change of direction the riders are obliged to show a minimum of 2 metres each in the respective direction.

(article introduced on 01.01.16)

8.3.037 50-cm-Spinnings (spin.)

Spinnings have to be performed on a spot with a ~~maximal~~ maximum diameter of 50 cm. The spinnings start being judged when the diameter has been achieved by all riders. All riders have to perform the required continuous spinnings according to the description of the figure. The described amount of spinnings has to be performed completely and continuously.

When spinnings are performed as a part of a figure with grip connection at the beginning and/or at the end of the figure the grip connection has to be released and closed in motion.

(article introduced on 01.01.16, text modified on 01.01.16; 01.01.17)

8.3.038 Star inside

All riders are standing, at the same distances between each other, without moving, around the middle of the riding-area. All are connected to each other by hand-in-hand grip connection. The bikes head tubes have to point to the middle of the riding-area. If the figure has to be shown inside individual, the grip connections have to be closed simultaneous. As soon as the grip connections are closed, the riders have to stand still.

(article introduced on 01.01.16)

8.3.039 Star outside

All riders are standing, at the same distances between each other, without moving, around the middle of the riding-area. All are connected to each other by hand-in-hand grip connection. The bikes rear wheels have to point to the middle of the riding area. If the figure has to be shown inside individual, the grip connections have to be closed simultaneous. As soon as the grip connections are closed, the riders have to stand still.

(article introduced on 01.01.16)

8.3.040 ½ turn on the spot

During the figure the grip connections will be released simultaneously and all riders perform, without pedalling, a half turn on the spot. As soon as the grip-connections are closed simultaneous, the riders have to stand still.

(article introduced on 01.01.16)

8.3.041 1 (or more) turn(s) on the spot

During the figure the grip connections will be released simultaneously and all riders perform, without pedalling, one (or more) turn(s) on the spot. As soon as the grip connections are closed simultaneous, the riders have to stand still.

(article introduced on 01.01.16)

8.3.042 Longline/shortline/diagonal pull

Line figures start 1 metre of the riders distance to the riding-areas's border, but they end 1 metre from the opposite border of the riding-area. The way of stretch has to be straight.

(article introduced on 01.01.16)

8.3.043 Descent from bicycle ~~at end of performance~~

At the end of the performance all riders have to descend ~~from their the~~ bicycle simultaneously and present themselves, while standing on the riding-area towards the audience. ~~After leaving the riding-area the evaluation ends~~ The evaluation ends at this moment (even after the ~~maximal maximum~~ time).

(text modified on 01.01.17)

Chapter IV TABLE OF FIGURES SINGLE ARTISTIC CYCLING

8.4.001 The values mentioned after "T" can be reached by tactical enlargement of the belonging figure.

8.4.002 Figures with both wheels on floor

Figure No. / Name of figure	Point value
1001 a Reg. seat HC.	0,5
1001 b Reg. seat C.	0,7
1001 c Reg. seat frh. HC.	0,7
1001 d Reg. seat frh. C.	0,9
1002 a Reg. seat bw. HC.	2,1
1002 b Reg. seat bw. C.	2,3
1002 c Reg. seat bw. frh. handlebar spinning s.r.	3,0
1003 a Reg. seat rev. HC.	1,2
1003 b Reg. seat rev. C.	1,4
1004 a Reg. seat rev. bw. HC.	1,9
1004 b Reg. seat rev. bw. C.	2,1
1004 c Reg. seat rev. bw. S	2,8
1004 d Reg. seat rev. bw. 8	3,6
1004 e Reg. seat rev. bw. frh. handlebar spinning s.r.	3,6
1011 a Steering with feet HC.	0,7
1011 b Steering with feet C.	0,9
1011 c Steering with feet frh. HC.	0,9
1011 d Steering with feet frh. C.	1,1
1012 a Lady seat HC.	0,8
1012 b Lady seat C.	1,0
1012 c Lady seat frh. HC.	1,2
1012 d Lady seat frh. C.	1,4
1013 a Lady seat bw. HC.	2,5
1013 b Lady seat bw. C.	2,7
1016 a Handlebarseat HC.	1,8
1016 b Handlebarseat C.	2,0
1016 c Handlebarseat frh. HC.	2,0
1016 d Handlebarseat frh. C.	2,2
1016 e Handlebarseat frh. S	2,6
1016 f Handlebarseat frh. 8	3,4
1017 a Handlebarseat rev. HC.	1,2
1017 b Handlebarseat rev. C.	1,4
1017 c Handlebarseat rev. frh. HC.	1,4
1017 d Handlebarseat rev. frh. C.	1,6
1021 a Split HC.	0,9
1021 b Split C.	1,1
1021 c Split frh. HC.	1,1

UCI CYCLING REGULATIONS

Figure No. / Name of figure	Point value
1021 d Split frh. C.	1,3
1022 a Split bw. HC.	2,6
1022 b Split bw. C.	2,8
1023 a Split rev. HC.	1,3
1023 b Split rev. C.	1,5
1023 c Split rev. frh. HC.	1,5
1023 d Split rev. frh. C.	1,7
1024 a Split rev. bw. HC.	2,6
1024 b Split rev. bw. C.	2,8
1031 a Frontstand HC.	1,8
1031 b Frontstand C.	2,0
1031 c Frontstand frh. HC.	2,0
1031 d Frontstand frh. C.	2,2
1031 e Frontstand frh. S	2,6
1031 f Frontstand frh. 8	3,4
1032 a Backstand HC.	2,0
1032 b Backstand C.	2,2
1036 a Side pedal stand HC.	1,3
1036 b Side pedal stand C.	1,5
1037 a Sidestand foot cranking HC.	1,2
1037 b Sidestand foot cranking C.	1,4
1038 a Sidestand HC.	1,2
1038 b Sidestand C.	1,4
1038 c Sidestand frh. HC.	1,4
1038 d Sidestand frh. C.	1,6
1039 a Sidestand rev. HC.	1,6
1039 b Sidestand rev. C.	1,8
1039 c Sidestand rev. frh. HC.	1,8
1039 d Sidestand rev. frh. C.	2,0
1040 a Side kneeling foot cranking HC.	1,2
1040 b Side kneeling foot cranking C.	1,4
1041 a Frameseat HC.	1,3
1041 b Frameseat C.	1,5
1046 a Stand on pins HC.	1,3
1046 b Stand on pins C.	1,5
1046 c Stand on pins frh. HC.	2,1
1046 d Stand on pins frh. C.	2,3
1046 e Stand on pins frh. S	2,7
1047 a Stand bent on pin HC.	1,6
1047 b Stand bent on pin C.	1,8

UCI CYCLING REGULATIONS

Figure No. / Name of figure	Point value
1047 c Stand bent on pin frh. HC.	3,0
1047 d Stand bent on pin frh. C.	3,2
1048 a Stand bent on pin bw. HC.	3,0
1048 b Stand bent on pin bw. C.	3,2
1051 a Bent knee seat HC.	1,3
1051 b Bent knee seat C.	1,5
1053 a Knee on saddle HC.	1,9
1053 b Knee on saddle C.	2,1
1054 a Knee on saddle bw. HC.	3,8
1054 b Knee on saddle bw. C.	4,0
1061 a Stand bent on saddle HC.	1,7
1061 b Stand bent on saddle C.	1,9
1062 a Stand bent on saddle bw. HC.	3,4
1062 b Stand bent on saddle bw. C.	3,6
1063 a Stand bent on frame HC.	1,7
1063 b Stand bent on frame C.	1,9
1064 a Stand bent on frame bw. HC.	3,4
1064 b Stand bent on frame bw. C.	3,6
1065 a Stand bent on frame rev. HC.	2,1
1065 b Stand bent on frame rev. C.	2,3
1066 a Stand bent on handlebar rev. HC.	2,2
1066 b Stand bent on handlebar rev. C.	2,3
1071 a Pedal side stand rev. HC,	1,2
1071 b Pedal side stand rev. C.	1,4
1076 a Framestand HC.	1,1
1076 b Framestand C.	1,3
1076 c Framestand frh. HC.	2,5
1076 d Framestand frh. C.	2,7
1076 e Framestand frh. S	3,1
1077 a Framestand rev. frh. HC.	3,1
1077 b Framestand rev. frh. C.	3,3
1081 a Fronthang HC.	1,5
1081 b Fronthang C.	2,1
1082 a Fronthang bw. HC.	3,4
1083 a Backhang HC.	1,3
1083 b Backhang C.	1,5
1083 c Backhang frh. HC.	1,5

UCI CYCLING REGULATIONS

Figure No. / Name of figure	Point value
1083 d Backhang frh. C.	1,7
1084 a Backhang bw. HC.	2,4
1091 a Lying on handlebar HC.	2,1
1091 b Lying on handlebar C.	2,3
1092 a Lying on saddle HC.	1,3
1092 b Lying on saddle C.	1,5
1092 c Lying on saddle handlebar HC.	1,5
1092 d Lying on saddle handlebar C.	1,7
1093 a Waterscale under saddle HC.	1,6
1093 b Waterscale under saddle C.	1,8
1093 c Waterscale on saddle HC.	1,8
1093 d Waterscale on saddle C.	2,0
1096 a Walk on frontwheel ¼ circle	2,4
1101 a Saddle handlebarstand HC.	2,9
1101 b Saddle handlebarstand C.	3,1
1101 c Saddle handlebarstand S	3,6
1101 d Saddle handlebarstand 8	4,1
1102 a Saddle handlebarstand bw. HC.	6,5
1102 b Saddle handlebarstand bw. C.	6,9
1102 c Saddle handlebarstand bw. S	7,8
1102 d Saddle handlebarstand bw. 8	9,2
1103 a Saddlestand HC.	5,7
1103 b Saddlestand C.	6,1
1103 c Saddlestand S	6,5
1103 d Saddlestand 8	7,3
1104 a Fronthandlebarstand HC.	4,0
1104 b Fronthandlebarstand C.	4,2
1104 c Fronthandlebarstand S	4,7
1104 d Fronthandlebarstand 8	5,2
1104 e Fronthandlebarstand HC. out of reg. seat	4,6
1104 f Fronthandlebarstand C. out of reg. seat	4,8
1104 g Fronthandlebarstand S out of reg. seat	5,3
1104 h Fronthandlebarstand 8 out of reg. seat.	5,8
1104 i Fronthandlebarstand ½ turn	5,1
1104 j Fronthandlebarstand 1 turn T (6,4 - 6,9 - 7,4 - 7,9)	5,9
1104 k Fronthandlebarstand 1½ turn T (7,2 - 7,7 - 8,2 - 8,7)	6,7
1104 l Fronthandlebarstand 2 turns T (8,0 - 8,5 - 9,0 - 9,5)	7,5
1104 m Fronthandlebarstand ½ turn out of reg. seat	5,7
1104 n Fronthandlebarstand 1 turn out of reg. seat T (7,0 - 7,5 - 8,0 - 8,5)	6,5
1104 o Fronthandlebarstand 1½ turn out of reg. seat T (7,8 - 8,3 - 8,8 - 9,3)	7,3
1104 p Fronthandlebarstand 2 turns out of reg. seat T (8,6 - 9,1 - 9,6 - 10,1)	8,1

		Given			
		1104i	1104j	1104k	1104l
Shown		½	1	1 ½	2
	½	5,1			
	1		5,9		
	1½		6,4	6,7	
	2		6,9	7,2	7,5
	2½		7,4	7,7	8,0
	3		7,9	8,2	8,5
	3½			8,7	9,0
	4				9,5

		Given			
		1104m	1104n	1104o	1104p
Shown		½	1	1 ½	2
	½	5,7			
	1		6,5		
	1½		7,0	7,3	
	2		7,5	7,8	8,1
	2½		8,0	8,3	8,6
	3		8,5	8,8	9,1
	3½			9,3	9,6
	4				10,1

Figure No. / Name of figure	Point value
1105 a Handlebarstand rev. HC.	4,4
1105 b Handlebarstand rev. C.	4,6
1105 c Handlebarstand rev. S	5,1
1105 d Handlebarstand rev. 8	5,6
1111 a Saddle support scale HC.	2,5
1111 b Saddle support scale C.	3,1
1111 c Saddle support scale S	3,5
1111 d Saddle support scale 8	5,1
1112 a Handlebar support scale HC.	2,5
1112 b Handlebar support scale C.	3,1
1112 c Handlebar support scale S	3,5
1112 d Handlebar grip scale, legs front HC.	3,5
1112 e Handlebar grip scale, legs front C.	4,2
1112 f Handlebar grip scale, legs front S	4,6
1112 g Handlebar grip scale, legs front 8	6,4
1112 h Handlebar grip scale, legs rear HC.	4,1
1112 i Handlebar grip scale, legs rear C.	4,8
1112 j Handlebar grip scale, legs rear S	5,2
1112 k Handlebar grip scale, legs rear 8	7,0
1115 a Handlebar L-shape hold HC.	2,8
1115 b Handlebar L-shape hold C.	3,2
1115 c Handlebar L-shape hold S	3,6
1115 d Handlebar L-shape hold 8	4,8
1116 a Handlebar L-shape hold rev. HC.	3,2
1116 b Handlebar L-shape hold rev. C.	3,6
1116 c Handlebar L-shape hold rev. S	4,0
1116 d Handlebar L-shape hold rev. 8	5,2
1117 a L-shape hold sideways HC.	3,8
1117 b L-shape hold sideways C.	4,4
1117 c L-shape hold sideways bw. HC.	6,5
1117 d L-shape hold sideways bw. C.	7,1

UCI CYCLING REGULATIONS

Figure No. / Name of figure	Point value
1118 a Handlebar support straddle HC.	3,3
1118 b Handlebar support straddle C.	3,9
1118 c Saddle support straddle HC.	4,2
1118 d Saddle support straddle C.	4,8
1121 a Headstand HC.	4,4
1121 b Headstand C.	4,6
1122 a Shoulderstand HC.	4,2
1122 b Shoulderstand C.	4,4
1123 a Saddle handlebar handstand HC.	7,0
1123 b Saddle handlebar handstand C.	7,8
1123 c Saddle handlebar handstand S	8,6
1123 d Saddle handlebar handstand 8	10,2
1123 e L-shape hold sdw. saddle handlebar handstand HC. T (9,8 - 10,4)	8,6
1123 f L-shape hold sdw. saddle handlebar handstand C. T (10,8 - 11,4)	9,6
1123 g L-shape hold sdw. saddle handlebar handstand S T (11,6 - 12,2)	10,4
1123 h L-shape hold sdw. saddle handlebar handstand 8 T (13,6 - 14,2)	12,4
1123 i L-shape hold sdw. swiss saddle handlebar handstand HC.	10,4
1123 j L-shape hold sdw. swiss saddle handlebar handstand C.	11,4
1123 k L-shape hold sdw. swiss saddle handlebar handstand S	12,2
1123 l L-shape hold sdw. swiss saddle handlebar handstand 8	14,2
1123 m L-shape hold sdw. german saddle handlebar handstand HC.	11,0
1123 n L-shape hold sdw. german saddle handlebar handstand C.	12,0
1123 o L-shape hold sdw. german saddle handlebar handstand S.	12,8
1123 p L-shape hold sdw. german saddle handlebar handstand 8.	14,8

		GIVEN			
		1123e	1123f	1123g	1123h
SHOWN	1123i	9,8			
	1123j		10,8		
	1123k			11,6	
	1123l				13,6
	1123m	10,4			
	1123n		11,4		
	1123o			12,2	
	1123p				14,2

Figure No. / Name of figure	Point value
1124 a Handlebar handstand HC.	7,2
1124 b Handlebar handstand C.	8,0
1124 c Handlebar handstand S	8,8
1124 d Handlebar handstand 8	10,4
1124 e L-shape hold handlebar handstand HC. T (10,0 - 10,6)	8,8
1124 f L-shape hold handlebar handstand C. T (11,0 - 11,6)	9,8
1124 g L-shape hold handlebar handstand S T (11,8 - 12,4)	10,6
1124 h L-shape hold handlebar handstand 8 T (13,8 - 14,4)	12,6
1124 i L-shape hold swiss handlebar handstand HC.	10,6

UCI CYCLING REGULATIONS

Figure No. / Name of figure	Point value
1124 j L-shape hold swiss handlebar handstand C.	11,6
1124 k L-shape hold swiss handlebar handstand S	12,4
1124 l L-shape hold swiss handlebar handstand 8	14,4
1124 m L-shape hold german handlebar handstand HC.	11,2
1124 n L-shape hold german handlebar handstand C.	12,2
1124 o L-shape hold german handlebar handstand S.	13,0
1124 p L-shape hold german handlebar handstand 8.	15,0

		Given			
Shown		1124e	1124f	1124g	1124h
	1124i	10,0			
	1124j		11,0		
	1124k			11,8	
	1124l				13,8
	1124m	10,6			
	1124n		11,6		
	1124o			12,4	
	1124p				14,4

Figure No. / Name of figure	Point value
1141 a Stillstand on pedals	1,0
1141 b Stillstand on pedals frh.	1,2
1141 c Stillstand pedal frontwheel	1,3
1141 d Stillstand pedal frontwheel frh.	1,5

(text modified on 01.01.12; 01.01.16)

8.4.003 Sidestand turn, squats and jumps

Figure No. / Name of figure	Point value
1151 a Sidestand turn	1,7
1156 a Reg. seat squat	1,7
1156 b Reg. seat squat bw.	3,1
1157 a Fronthang squat with use of pin	1,8
1157 b Fronthang squat	2,0
1157 c Fronthang squat bw.	3,5
1158 a Backhang squat with use of pin	1,7
1158 b Backhang squat	1,9
1158 c Backhang squat bw.	3,5
1159 a Handlebarseat rev. squat	1,7
1159 b Handlebarseat rev. squat bw.	2,9
1171 a Handlebarseat rev. scissors jump	2,2
1171 b Backhang scissors jump	2,6

UCI CYCLING REGULATIONS

Figure No. / Name of figure	Point value
1172 a Turning jump sidestand handlebarseat rev.	2,0
1172 b Turning jump reg. seat handlebarseat rev.	2,3
1172 c Turning jump handlebarseat rev. reg. seat	2,3
1172 d Turning jump reg. seat stand bent on frame rev.	2,8
1172 e Turning reg. seat, jump, scissors jump	3,8
1173 a Turning jump sidestand front wheel walk	2,2
1173 b Turning jump reg. seat front wheel walk	2,8
1174 a Turning jump sidestand backhang	1,8
1174 b Turning jump reg. seat backhang	2,2
1174 c Turning jump backhang reg. seat	2,3
1175 a Turning jump 1 turn	4,2
1175 b Turning jump 2 turns T (6,3 - 7,0 - 7,7 - 8,4 - 9,1)	5,6
1175 c Turning jump 3 turns T (7,6 - 8,3 - 9,0 - 9,7 - 10,4)	6,9
1175 d Turning jump 4 turns T (8,8 - 9,5 - 10,2 - 10,9 - 11,6)	8,1
1175 e Turning jump 5 turns T (9,9 - 10,6 - 11,3 - 12,0 - 12,7)	9,2

Given						
Shown	1175a	1175b	1175c	1175d	1175e	
	1	2	3	4	5	
	1	4,2				
	2		5,6			
	3		6,3	6,9		
	4		7,0	7,6	8,1	
	5		7,7	8,3	8,8	9,2
	6		8,4	9,0	9,5	9,9
	7		9,1	9,7	10,2	10,6
	8			10,4	10,9	11,3
	9				11,6	12,0
10					12,7	

Figure No. / Name of figure	Point value
1181 a Pedal jump	1,9
1186 a Maute jump	7,3

(text modified on 01.01.16)

8.4.004 Raiser figures

Figure No. / Name of figure	Point value
1201 a Raiser reg. seat HC.	2,4
1201 b Raiser reg. seat C.	2,6
1201 c Raiser reg. seat frh. HC.	2,5
1201 d Raiser reg. seat frh. C.	2,7
1201 e Raiser reg. seat 1 leg HC.	3,1
1201 f Raiser reg. seat 1 leg C.	3,3
1201 g Raiser reg. seat 1 leg frh. HC.	3,4
1201 h Raiser reg. seat 1 leg frh. C.	3,6
1202 a Raiser reg. seat bw. HC.	4,3

UCI CYCLING REGULATIONS

Figure No. / Name of figure	Point value
1202 b Raiser reg. seat bw. C.	4,5
1202 c Raiser reg. seat bw. frh. HC.	4,6
1202 d Raiser reg. seat bw. frh. C.	4,8
1202 e Raiser reg. seat bw. 1 leg HC.	5,7
1202 f Raiser reg. seat bw. 1 leg C.	6,5
1202 g Raiser reg. seat bw. 1 leg frh. HC.	6,7
1202 h Raiser reg. seat bw. 1 leg frh. C.	7,5
1202 i Raiser reg. seat spin. bw. frh.	5,3
1203 a Raiser reg. seat rev. frh. HC.	3,1
1203 b Raiser reg. seat rev. frh. C.	3,5
1203 c Raiser reg. seat rev. frh. S	3,9
1203 d Raiser reg. seat rev. frh. 8	5,1
1203 e Raiser reg. seat rev. frh. 1 leg frh. HC.	3,9
1203 f Raiser reg. seat rev. frh. 1 leg frh. C.	4,6
1203 g Raiser reg. seat rev. spin. frh.	5,7
1204 a Raiser reg. seat rev. bw. frh. HC.	4,8
1204 b Raiser reg. seat rev. bw. frh. C.	5,2
1204 c Raiser reg. seat rev. bw. frh. S	6,3
1204 d Raiser reg. seat rev. bw. frh. 8	7,8
1211 a Raiser lady seat HC.	3,1
1211 b Raiser lady seat C.	3,3
1211 c Raiser lady seat frh. HC.	3,4
1211 d Raiser lady seat frh. C.	3,6
1212 a Raiser lady seat bw. HC.	5,4
1212 b Raiser lady seat bw. C.	6,2
1212 c Raiser lady seat bw. frh. HC.	6,4
1212 d Raiser lady seat bw. frh. C.	7,2
1216 a Raiser stand on pin HC.	3,0
1216 b Raiser stand on pin C.	3,2
1216 c Raiser stand on pin frh. HC.	3,3
1216 d Raiser stand on pin frh. C.	3,5
1216 e Raiser sidestand HC.	3,2
1216 f Raiser sidestand C.	3,4
1216 g Raiser sidestand frh. HC.	3,5
1216 h Raiser sidestand frh. C.	3,7
1217 a Raiser stand on pin bw. HC.	5,2
1217 b Raiser stand on pin bw. C.	6,0
1217 c Raiser stand on pin bw. frh. HC.	6,2
1217 d Raiser stand on pin bw. frh. C.	7,0
1217 e Raiser stand on pin spin. bw.	7,2
1217 f Raiser sidestand bw. HC.	4,8
1217 g Raiser sidestand bw. C.	5,6
1219 a Raiser stand on pin rev. bw. HC.	3,9
1219 b Raiser stand on pin rev. bw. C.	4,7
1219 c Raiser sidestand rev. bw. HC.	4,2
1219 d Raiser sidestand rev. bw. C.	5,0

UCI CYCLING REGULATIONS

Figure No. / Name of figure	Point value
1226 a Raiser handlebarseat HC.	2,5
1226 b Raiser handlebarseat C.	2,7
1226 c Raiser handlebarseat frh. HC.	2,6
1226 d Raiser handlebarseat frh. C.	2,8
1227 a Raiser handlebarseat bw. HC.	4,3
1227 b Raiser handlebarseat bw. C.	4,5
1227 c Raiser handlebarseat bw. frh. HC.	4,4
1227 d Raiser handlebarseat bw. frh. C.	4,6
1227 e Raiser handlebarseat spin. bw. frh.	5,1
1228 a Raiser handlebarseat rev. frh. HC.	3,0
1228 b Raiser handlebarseat rev. frh. C.	3,4
1228 c Raiser handlebarseat rev. frh. S	3,8
1228 d Raiser handlebarseat rev. frh. 8	5,0
1228 e Raiser handlebarseat rev. spin. frh.	5,5
1229 a Raiser handlebarseat rev. bw. frh. HC.	4,8
1229 b Raiser handlebarseat rev. bw. frh. C.	5,2
1229 c Raiser handlebarseat rev. bw. frh. S	5,9
1229 d Raiser handlebarseat rev. bw. frh. 8	7,4
1236 a Raiser headtube frh. HC.	2,6
1236 b Raiser headtube frh. C.	2,8
1236 c Raiser headtube 1 leg frh. HC.	3,0
1236 d Raiser headtube 1 leg frh. C.	3,2
1236 e Raiser headtube spin. frh.	5,1
1237 a Raiser headtube bw. frh. HC.	4,4
1237 b Raiser headtube bw. frh. C.	4,6
1237 c Raiser headtube spin. bw. frh.	5,1
1238 a Raiser headtube rev. frh. HC.	3,0
1238 b Raiser headtube rev. frh. C.	3,4
1238 c Raiser headtube rev. spin. frh.	5,5
1239 a Raiser headtube rev. bw. frh. HC.	4,8
1239 b Raiser headtube rev. bw. frh. C.	5,2
1246 a Standraiser HC.	4,0
1246 b Standraiser C.	4,6
1247 a Standraiser bw. HC.	5,3
1247 b Standraiser bw. C.	5,9
1247 c Standraiser spin. bw.	6,5
1248 a Standraiser rev. HC.	4,2
1248 b Standraiser rev. C.	4,8
1248 c Standraiser rev. spin.	6,5
1249 a Standraiser rev. bw. HC.	5,5
1249 b Standraiser rev. bw. C.	6,1

UCI CYCLING REGULATIONS

Figure No. / Name of figure	Point value
1249 c Standraiser rev. bw. S	6,8
1249 d Standraiser rev. bw. 8	8,8

(text modified on 01.01.16; 01.01.17)

8.4.005 Raiser passages

Figure No. / Name of figure	Point value
1281 a P. fronthang raiser headtube	5,0
1281 b P. raiser headtube fronthang	2,4
1282 a P. fronthang standraiser rev.	7,0
1282 b P. standraiser rev. fronthang	3,0
1283 a P. raiser reg. seat raiser handlebarseat	3,1
1283 b P. raiser handlebarseat raiser reg. seat	2,1
1284 a P. raiser reg. seat raiser headtube	5,3
1284 b P. raiser headtube raiser reg. seat	4,3
1285 a P. raiser reg. seat raiser standraiser rev.	6,4
1285 b P. standraiser rev. raiser reg. seat	4,7
1286 a P. raiser handlebarseat raiser headtube	3,6
1286 b P. raiser headtube raiser handlebarseat	2,7
1287 a P. raiser headtube standraiser rev.	4,1
1287 b P. standraiser rev. raiser headtube	1,9
1288 a P. backhang raiser headtube rev.	3,7
1288 b P. raiser headtube rev. backhang	1,4
1289 a P. backhang standraiser	6,1
1289 b P. standraiser backhang	2,4
1290 a P. reg. seat rev. raiser handlebarseat rev.	5,1
1290 b P. raiser handlebarseat rev. reg. seat rev.	1,7
1291 a P. raiser handlebarseat rev. standraiser	6,8
1291 b P. standraiser raiser handlebarseat rev.	5,1
1292 a P. raiser headtube rev. raiser handlebarseat rev.	3,9
1292 b P. raiser handlebarseat rev. raiser headtube rev.	5,8
1293 a P. standraiser raiser headtube rev.	1,8
1293 b P. raiser headtube rev. standraiser	3,6

(text modified on 01.01.16; 01.01.17)

8.4.006 Final figures

Figure No. / Name of figure	Point value
1301 a Reg. seat handlebar squat	1,4

UCI CYCLING REGULATIONS

Figure No. / Name of figure	Point value
1301 b Side pedal stand squat over bike	1,9
1301 c Reg. seat handlebar straddle	3,5
1301 d Reg. seat handlebar squat ½ twist	2,5
1301 e Handlebarseat rev. handlebar squat	1,6
1301 f Handlebarseat rev. handlebar straddle	3,7
1301 g Stand bent on saddle handstandloop	6,6
1301 h Reg. seat handstandloop	7,7
1301 i Fronthandlebarstand stretchjump over bike	4,3
1301 j Fronthandlebarstand stretchjump in front of bike ½ twist	5,1
1301 k Fronthandlebarstand straddlejump behind the bike	4,7
1301 l Handlebarstand rev. stretchjump in front of bike	4,6
1301 m Handlebarstand rev. stretchjump in front of bike 1 twist	6,2
1301 n Handlebarstand rev. somersault bw. hooked legs	8,6
1301 o Handstand bicycle lying down	4,1
1301 p L-shape hold swiss handstand bicycle lying down	6,1

(text modified on 01.01.16)

Chapter V EXPLANATIONS OF FIGURES SINGLE ARTISTIC CYCLING

8.5.001 Figures with both wheels on the floor

Reg. seat

Regular seat on saddle, both feet each on a pedal. Chest directed to handlebar.

1002c: with continuous handlebarspinning, a complete single ring must be performed free-hand.



1001
1002

Reg. seat rev.

Regular seat reversed on saddle, both feet each on a pedal. Back directed to the handlebar.

1004e: with continuous handlebarspinning, a complete single ring must be performed free-hand.



1003
1004

Steering with feet

Regular seat on saddle, both feet on the handlebar.



1011

Lady seat

Regular seat on saddle, one foot on a pedal. The free leg must be stretched over the top tube to the opposite side of the bicycle and below the handlebar. The handlebar may not be touched by the leg or foot.



1012
1013

Handlebarseat

Seat on handlebar, back directed to the saddle. The free leg must be stretched forward, horizontally. Other foot hooked to the down tube.



1016

Handlebarseat rev.

Reversed seat on handlebar, both feet each on a pedal. Chest directed to the saddle.



1017

Split

Left foot standing on left rear-pin, right foot standing on right front-pin (or counterwise). Chest directed to the handlebar. The handlebar may not be touched with the leg.



1021
1022

Split rev.

Right foot standing on the left rear-pin, left foot standing on the right-frontpin (or counterwise). Chest directed to the saddle. The handlebar may not be touched with the leg.



1023
1024

Frontstand

Stand in front of the handlebar, back directed to the saddle. One foot on frontpin, other foot hooked to the down tube.



1031

Backstand

Stand with one foot on frontpin, handlebar in front of the rider. Chest directed to the saddle. The free leg must be stretched in moving-direction. Legs may not touch the handlebar. Riders head, body, leg and foot must show a straight line.



1032

Side pedal stand

Stand with both feet on one pedal (legs closed next to each other). Chest directed to the handlebar.



1036

Sidestand foot cranking

One foot standing on left rear-pin, other foot on left pedal (or counterwise). Chest directed to the handlebar.



1037

Sidestand

Stand with one foot on left rear-pin, other foot on left front-pin (or counterwise). Chest directed to the handlebar. The handlebar may not be touched with the leg.



1038

Sidestand rev.

Reversed stand with one foot on left rear-pin, other foot on left front-pin (or counterwise). Chest directed to the saddle. The handlebar may not be touched with the leg.



1039

Side kneeling foot cranking

Sideways kneeling on saddle with one knee. Other foot on pedal.



1040

Frameseat

Pushing one foot through the frame and placing foot on front-pin. Free leg stretched forward, while sitting on the down tube.



1041

Stand on pins

Standing with both feet each on a rear-pin. Both knees behind the saddle.



1046

Stand bent on pin

One foot standing on rear-pin, trunk bent forward, free leg stretched to the back in straight line with the trunk.



1047

1048

Bent knee seat

In squat position with one foot on top tube, free leg horizontally stretched forward, back directed to the saddle.



1051

Knee on saddle

Knee on saddle, trunk bent forward, free leg stretched to the back in straight line with the trunk.



1053

1054

Stand bent on saddle

One foot standing on the saddle, trunk bent forward, free leg stretched to the back in straight line with the trunk.



1061
1062

Stand bent on frame

One foot standing on the top tube, trunk bent forward, free leg stretched to the back in straight line with the trunk.



1063
1064

Stand bent on frame rev.

Reversed stand with one foot on the top tube, trunk bent downwards, free leg stretched in moving-direction in straight line with the trunk.



1065

Stand bent on handlebar rev.

Reversed stand with one foot on the handlebar, trunk bent downwards. One hand on saddle, other hand on handlebar. Free leg stretched in moving-direction in straight line with the trunk.



1066

Pedal side stand rev.

Reversed on bicycle with one leg through the frame, both feet standing on ~~each-a the~~ pedals. Chest directed to the saddle.



1071

Framestand

Standing upright with one foot standing on the down tube, other foot standing on the saddle tube. Chest directed to handlebar. Feet may not touch each other, legs may not touch the handlebar.



1076

Framestand rev.

Standing reversed with one foot on the down tube, other foot on the saddle tube. Chest directed to the saddle. Feet may not touch each other, legs may not touch the handlebar.



1077

Fronthang

Both hands leaning, behind the back, on the handlebar, frontwheel between the legs. Both feet on ~~each-a the~~ pedals.



1081
1082

Backhang

In front of the headtube hanging on the handlebar. Chest directed to the saddle, frame between the legs, both feet on ~~each-a the~~ pedals.



1083
1084

Lying on handlebar

Lying with front of body on the handlebar, head directed to the saddle. Closed legs stretched horizontally in moving direction.



1091

Lying on saddle, Lying on saddle and handlebar

a-b: Lying with front of body on the saddle, closed stretched legs to the back.

c-d: Lying with front of body on saddle, arms stretched sideways free-hand on handlebar-grips. Closed legs stretched horizontally to the back.



1092

Waterscale

Lying with back of body straight line on handlebar, stretched legs or feet under (a and b), or on (c and d) saddle.



1093

Walk on front wheel ¼ circle

Walking with both feet on front wheel tyre, both hands on handlebar. Chest directed to the saddle. The way of stretch for this figure has to be at least ¼ circle.



1096

Saddle handlebarstand

Standing free, upright stretched with one foot on saddle and the other foot on the handlebar.



1101
1102

Saddlestand

Standing free, upright stretched with both feet on saddle.



1103

Fronthandlebarstand, Fronthandlebarstand turn T

Standing free, upright with both feet on handlebar-grips, back directed to the saddle.

From one turn on the tactical enlargement of the fronthandlebarstand turn(s) is possible up to four half turns in maximum.

e - h: The rider jumps from regular seat to fronthandlebarstand.

i - l: From fronthandlebarstand with half or multiple front wheel turn to fronthandlebarstand or handlebarstand reverse. After the last turn, the end position must be held for at least 2 metres.

m - p: The rider jumps from regular seat to fronthandlebarstand; further according figure i – l.



1104

Handlebarstand rev.

Standing, reversed, free, upright stretched with both feet on handle-bar-grips, chest directed to the saddle.



1105

Saddle support scale

One hand on saddle, elbow supporting the body, other hand on handlebar (handlebar-grip may be used as support for the fore-arm). Head directed in moving-direction, closed legs stretched horizontally to the back. Legs and upper part of the body have to build a straight line.



1111

Handlebar support scale

One hand on handlebar, elbow supporting the body, other hand on saddle. Head directed to saddle, closed legs stretched horizontally in moving direction. Legs and upper part of the body have to build a straight line.



1112 a
1112 b
1112 c
1112 d

Handlebar grip scale, legs front

Both hands on handlebar, elbows supporting the body. Closed legs stretched horizontally in moving-direction. Head directed to the saddle. Legs and upper part of the body have to build a straight line.



1112 d
1112 e
1112 f
1112 g

Handlebar grip scale, legs rear

Both hands on handlebar, elbows supporting the body. Closed legs stretched horizontally above the saddle. Head directed to moving-direction. Legs and upper part of the body have to build a straight line.



1112 h
1112 i
1112 j
1112 k

Handlebar L-shape hold

Arms stretched, hands on handlebar-grips. Legs closed and horizontally stretched in moving direction. Back directed to the saddle.



1115

Handlebar L-shape hold rev.

Reversed position on bicycle. Arms stretched, hands on handlebar-grips. Legs closed and horizontally stretched. Chest directed to the saddle.



1116

L-shape hold sideways

Arms stretched, one hand on saddle, other hand on handlebar. Legs closed and horizontally stretched sideways. Fore-arm or wrist may not lean against handlebar-grip.

1117

Handlebar support straddle, Saddle support straddle.

a-b: Arms stretched, hands on handlebar-grips. Legs horizontally stretched, straddled on the outside of the arms.

c-d: Arms stretched, hands on saddle. Legs horizontally ~~straddled and~~ stretched, ~~straddled on the outside of the arms~~, without touching the handlebar.



1118

Headstand

Headstand on the saddle, both hands on the handlebar. Legs closed and **vertically** stretched **straight upwards**.



1121

Shoulderstand

Shoulderstand with one shoulder on saddle or top tube, both hands on the handlebar. Legs closed and **vertically** stretched **straight upwards**.



1122

Saddle handlebar handstand

Handstand with one hand on handlebar and other hand on saddle. Arms stretched, legs closed and **vertically** stretched **straight upwards**. The fore-arm or the wrist may not be leaned against the handlebar-grip.



1123 a
1123 b
1123 c
1123 d

L-shape hold sideways saddle handlebar handstand (T)

From the L-shape hold sideways, which has to be performed for at least 2 metres, going directly to handstand without touching the frame with foot/feet. The handstand must be performed as described in figures **1123a-d** and held through the whole way of stretch.

The tactical enlargement is possible for the kind of execution as Swiss saddle handlebar handstand which has to be performed like the figures **1123i-l**.

The tactical enlargement is possible for the kind of execution as German saddle handlebar handstand which has to be performed like the figures **1123m-p**.

1123 e
1123 f
1123 g
1123 h

L-shape hold sideways Swiss saddle handlebar handstand

From the L-shape hold sideways, which has to be performed for at least 2 metres, going directly to handstand with stretched legs over the frame but without touching the frame **and/or handlebar** with foot/feet. After passing the frame, with stretched and straddled legs to the handstand, which has to be performed as described in figures **1123a-d** and held through the whole way of stretch.

1123 i
1123 j
1123 k
1123 l

L-shape hold sideways German saddle handlebar handstand

From the L-shape sideways, which has to be performed for at least 2 metres, going directly to handstand with stretched, closed legs over the frame without touching the frame or else with foot/feet. After passing the frame with stretched, closed legs to the handstand, which has to be performed as described in figures **1123a-d** and held through the whole way of stretch.

1123 m
1123 n
1123 o
1123 p

Handlebar handstand

Handstand with both hands on handlebar-grips. Arms stretched, legs closed and **vertically** stretched **straight upwards**.

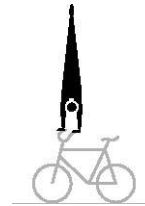

1124 a
1124 b
1124 c
1124 d

L-shape hold handlebar handstand (T)

From L-shape hold or L-shape hold rev., which have to be performed for at least 2 metres, going directly to handstand without touching the handlebar and/or frame with foot/feet. The handstand must be performed as described in figures **1124a-d** and held through the whole way of stretch.

The tactical enlargement is possible for the kind of execution as Swiss handlebar handstand which has to be performed like the exercises **1124i-l**.

The tactical enlargement is possible for the kind of execution as German handlebar handstand which has to be performed like the exercises **1124m-p**.

1124 e
1124 f
1124 g
1124 h

L-shape hold Swiss handlebar handstand

From L-shape hold or L-shape hold rev., which has to be performed for at least 2 metres, going directly to handstand with stretched legs over the handlebar without touching the handlebar and/or frame with foot/feet. After passing the handlebar, with stretched and straddled legs to the handstand, which has to be performed as described in figures **1124a-d** and held through the whole way of stretch.

1124 i
1124 j
1124 k
1124 l

L-shape hold German handlebarstand

From the L-shape hold or L-shape hold rev., which has to be performed for at least 2 metres, going directly to handstand with stretched, closed legs over the handlebar without touching the handlebar or else with foot/feet. After passing the handlebar with stretched, closed legs to the handstand, which has to be performed as described in figures **1124a-d** and held through the whole way of stretch.

1124m
1124 n
1124 o
1124 p

Stillstand on pedals, Stillstand pedal front wheel

a-b: Standing with both feet, only, on ~~each~~ **the** pedals. Back directed to the saddle. The stillstand has to be performed for at least 3 seconds.

c-d: Standing with one foot, only, on a pedal, the other foot on front wheel tyre. Back directed to the saddle. The stillstand has to be performed for at least 3 seconds.



1141

(text modified on 01.01.12; 01.01.16; 01.01.17)

8.5.002 Sidestand turn, squats and jumps

Sidestand turn

Chest directed to handlebar, right foot on right front-pin and left foot on the right pedal (or counterwise). With half turn of handlebar and front wheel to backhang. While



1151 a

performing the turn, the foot may not leave the pedal.

Reg. seat squat

- a: While riding forward, squat from regular seat over the handlebar to riding forward in fronthang.
- b: While riding backwards, squat from regular seat over the handle-bar to riding backwards in fronthang.

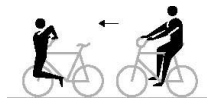

1156

Fronthang squat

- a: While riding forward, squat from fronthang over the handlebar to riding forward in regular seat. Pushing off one foot from a front-pin is allowed.
- b: Like a: but without pushing off from front-pin.
- c: While riding backwards, squat from fronthang over the handlebar to riding backwards in regular seat.

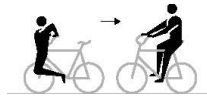

1157

Backhang squat

- a: While riding forward, squat from backhang over handlebar to riding forward in handlebarseat reverse. Pushing off one foot from a frontpin is allowed.
- b: Like a: but without pushing off front front-pin.
- c: While riding backwards, squat from backhang over handlebar to riding backwards in handlebarseat reverse.



1158

Handlebarseat rev. squat

- a: While riding forward, squat from handlebarseat reverse over handlebar to riding forward in backhang.
- b: While riding backwards, squat from handlebarseat reverse over handlebar to riding backwards in backhang.



1159

Handlebarseat rev. Scissors jump

While riding forward from handlebarseat reverse crossing stretched legs above the saddle. Then changing grips to riding forward in regular seat. Turning the upper part of the body while crossing or grip-changing. Intermediate sitting, after crossing, on frame or handlebar is allowed.



1171 a

Backhang scissors jump

While riding forward, squat from backhang over the handlebar without an intermediate seat in position handlebarseat rev., crossing stretched legs above the saddle. Then changing grips to riding forward in regular seat. Turning the upper part of the body while crossing or grip-changing. Intermediate sitting, after crossing, on frame or handlebar is allowed.

1171 b

Turning jump / Turning-scissors jump

a: While riding forward from sidestand foot-cranking jump with half turn of handlebar and front wheel, then squat over handlebar to riding forward in handlebar reverse. During the jump it is not allowed to leave the foot on the pedal.

b: While riding forward from regular seat jump with half turn of handlebar and front wheel, then squat over handlebar to riding forward in handlebar reverse. During the jump it is not allowed to leave the foot on the pedal.

c: While riding forward from handlebarseat reverse squat over the handlebar, immediately followed by jump with half turn of the handlebar and front wheel to riding forward in regular seat.

d: While riding forward from regular seat jump with half turn of handlebar and front wheel to riding forward in stand bent on frame reverse.

e: While riding forward from regular seat jump with half turn of handlebar and frontwheel over the handlebar, without an intermediate seat in position handlebarseat rev., crossing stretched legs over the saddle, and changing grips to riding forward in regular seat. Turning the upper part of the body while crossing or grip-changing. Intermediate sitting, after crossing, on frame or handlebar is allowed.



1172

Turning jump

a: While riding forward from sidestand foot cranking jump with half turn of handlebar and front wheel to riding forward in walk on front wheel. During the jump it is not allowed to leave the foot on the pedal.

b: While riding forward from regular seat jump with half turn of handlebar and front wheel to riding forward in walk on front wheel.

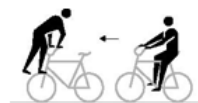

1173

Turning jump

a: While riding forward from sidestand foot cranking with half turn of the handlebar and front wheel to riding in backhang. During the jump it is not allowed to leave the foot on the pedal.

b: While riding forward from regular seat with half turn of the handlebar and front wheel to riding backhang.

c: While riding forward from backhang with half turn of the handlebar and front wheel to riding regular seat.



1174

Turning jump (T)

The tactical enlargement of the turning jumps is possible from two to seven, three to eight, from four to nine and from five to ten turning jumps.

a: While riding forward from regular seat jump with whole turn of the front wheel to riding forward in regular seat.

b-e: While riding forward from regular seat jump with, continuous multiple turns to riding forward in regular seat.



1175

Pedal jump

From side pedal stand jump simultaneously with both feet over the top tube to side pedal stand on the other side of the bicycle.



1181

Maute jump

Jump from saddlestand to fronthandlebarstand which has to be performed, after the jump, for at least 2 metres.

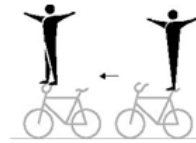

1186

(text modified on 01.01.16)

8.5.003 Raiser figures

Raiser reg. seat

a-d/i: Regular raiser with seat on saddle, chest directed to handlebar, both feet on ~~each-a~~ the pedals.

e-h: Regular raiser with seat on saddle, chest directed to handlebar, one foot on pedal. The free leg has to be stretched and may not touch the bicycle.



1201

1202

Raiser reg. seat rev.

a-d/g: Reversed regular raiser with seat on saddle, back directed to handlebar, both feet on ~~each-a~~ the pedals.

e-f: Reversed regular raiser with seat on saddle, back directed to handlebar, one foot on pedal. The free leg has to be stretched and may not touch the bicycle.



1203

1204

Raiser lady seat

Raiser with seat on saddle, chest directed to handlebar, one foot on pedal. The free leg must be stretched over the top tube to the opposite side of the bicycle, below the handlebar without the foot wedging the front wheel.



1211

1212

Raiser stand on pin / raiser stand on pin bw.

1216a-d/1217a-e: Raiser standing with left foot on left rear-pin and with right foot on right pedal (or counterwise). Chest directed to handlebar.



1216

1217

Raiser sidestand / raiser sidestand bw.

1216e-h/1217f-g: Raiser standing with one foot on the right rear-pin and with the other on the right pedal (or counterwise). Chest directed to handlebar.

1216

1217

Raiser stand on pin rev.

Raiser standing with right foot on left rear-pin and left foot on the right pedal (or counterwise). Back directed to handlebar.



1219 a

1219 b

Raiser sidestand rev.

Raiser standing with one foot on right rear-pin and the other foot on right pedal (or counterwise). Back directed to the handlebar.

1219 c

1219 d

Raiser handlebarseat

Raiser, ~~with seat in on~~ the lower part of the handlebar (~~front wheel with crossed position~~), chest facing towards the front wheel. Both feet on ~~each-a the~~ pedals. ~~Chest directed to the front wheel.~~



1226
1227

Raiser handlebarseat rev.

Reversed raiser, ~~with seat in on~~ the lower part of the handlebar (~~front wheel with crossed position~~), back directed to the front wheel. Both feet on ~~each-a the~~ pedals.



1228
1229

Raiser head tube

Raiser sitting on the head tube, both feet on ~~each-a the~~ pedals. Front wheel in front of oneself.



1236 a
1236 b
1236 e
1237

Raiser head tube 1 leg

Raiser sitting on the head tube, one foot on pedal. The free leg has to be stretched and may not touch the bicycle.

1236 c
1236 d

Raiser head tube rev.

Reversed raiser sitting on the head tube, both feet on ~~each a the~~ pedals. Front wheel behind oneself.



1238
1239

Standraiser

Raiser. Saddle pointing downwards, holding front wheel ~~with one hand~~ in front of oneself. Standing with both feet on ~~each-a the~~ pedals.



1246
1247

Standraiser rev.

Reversed raiser. Saddle pointed downwards, holding front wheel ~~with one hand~~ behind oneself. Standing with both feet on ~~each-a the~~ pedals.



1248
1249

(text modified on 01.01.17)

8.5.004 Raiser passages

Passages

Execution according 8.2.039 "Passages"

1281-
1293

8.5.005 Final figures

It is only allowed to perform one final figure as last figure of the riders program. The rider has to end the figure standing on the riding-area (except for figure **o** and **p**), holding the bicycle in one hand. The other hand has to be stretched, horizontally sideways.

- Reg. seat handlebar squat** 1301 a
 From position regular seat squat over the handlebar to standing with both feet on the floor. During the jump it is not allowed to release the handlebar with one or two hands.
- Side pedal stand squat over the bike** 1301 b
 From position side pedal stand (both feet on one pedal) squat over the frame to standing with both feet on the floor. During the jump it is not allowed to release the handlebar with one or two hands.
- Reg. seat handlebar straddle** 1301 c
 From position regular seat jump with straddled legs over the handlebar to standing with both feet on the floor. During the jump the rider it is not allowed to touch or hold the handlebar with one or both hands.
- Reg. seat handlebar squat ½ twist** 1301 d
 From position regular seat squat over the handlebar with a ½ twist to standing with both feet on the floor. The ½ twist has to end before the rider is standing on the floor. After the jump over the handlebar the rider has to release the handlebar until the end of the ½ twist.
- Handlebarseat rev. handlebar squat** 1301 e
 From position handlebarseat reverse squat over the handlebar to standing with both feet on the floor. During the jump ~~it is not allowed to release~~ the handlebar ~~has to be held on~~ with ~~one or two~~ both hands.
- Handlebarseat rev. handlebar straddle** 1301 f
 From position handlebarseat reverse jump with straddled legs over the handlebar to standing with both feet on the floor. During the jump the rider it is not allowed to touch or hold the handlebar with one or both hands.
- Stand bent on saddle handstandloop** 1301 g
 From position stand bent on saddle with handstandloop to standing with both feet on the floor. The handstand has to be performed with stretched arms and stretched and closed legs/feet above the handlebar. A short stop of the loop at this position is no obligation. After the handstand both hands have to be released from the handlebar, after the following rotation of the body the rider has to land with both feet at the floor.
- Reg. seat handstandloop** 1301 h
 From position regular seat jump, without stop, with handstandloop to standing with both feet on the floor. The handstand has to be performed with stretched arms and stretched and closed legs/feet above the handlebar. A short stop of the loop at this position is no obligation. After the handstand both hands have to be released from the handlebar, after the following rotation of the body the rider has to land with both feet at the floor.
- Fronthandlebarstand stretchjump over bike** 1301 i
 From position fronthandlebarstand with stretchjump upwards, with complete stretched body and closed legs, to standing with both feet on the floor, behind the bicycle.

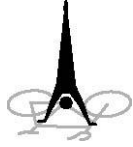
- Fronthandlebarstand stretchjump in front of bike ½ twist** 1301 j
 From position fronthandlebarstand with stretchjump upwards, with complete stretched body and closed legs, and a ½ twist to standing with both feet on the floor, in front of the bicycle.
- Fronthandlebarstand straddlejump behind the bike** 1301 k
 From position fronthandlebarstand with straddle-jump, with straddled and horizontally stretched legs, to standing with both feet at the floor, behind the bicycle. At the stretched-straddled position the hands have to touch each one foot.
- Handlebarstand rev. stretchjump in front of bike** 1301 l
 From position handlebarstand reverse with stretchjump upwards, with complete stretched body and closed legs, to standing with both feet on the floor, in front of the bicycle.
- Handlebarstand rev. stretchjump in front of bike 1 twist** 1301 m
 From position handlebarstand reverse with stretchjump upwards, with complete stretched body and closed legs, and 1 twist to standing with both feet on the floor, in front of the bicycle.
- Handlebarstand rev. somersault bw. hooked legs** 1301 n
 From position handlebarstand reverse somersault-jump backwards with hooked legs to standing with both feet on the floor, in front of bicycle.
- Handstand bicycle lying down** 1301 o
 Handstand on bicycle lying down on floor with stretched arms, **legs closed and stretched straight upwards and closed-legs**. The fore-arms or wrists may not lean on handlebar, saddle or pedal. The handstand has to be performed for at least 3 seconds.
- 
- L-shape hold swiss handstand bicycle lying down** 1301 p
 From position l-shape hold performed on the bicycle lying down on the riding-area, which has to be shown for at least 3 seconds, going to handstand with stretched legs over the frame but without touching the bicycle with foot/feet. After passing the frame/bicycle, with stretched and straddled legs and stretched arms direct to the handstand, which has to be performed like the figure 1301o. The handstand has to be shown for at least 3 seconds.

(text modified on 01.01.16; 01.01.17)

Chapter VI TABLE OF FIGURES PAIR ARTISTIC CYCLING

8.6.001 The values mentioned after "T" can be reached by tactical extension of the belonging figure.

8.6.002 Figures with both wheels on floor on two bicycles

Figure No. / Name of figure	Point value
2001 a Reg. seat HC.	0,4
2001 b Reg. seat C.	0,5
2001 c Reg. seat frh. HC.	0,8
2001 d Reg. seat frh. C.	0,9
2001 e Reg. seat mill	0,5
2001 f Reg. seat mill frh.	0,9
2001 g Reg. seat mill s.r. frh.	1,5
2002 a Reg. seat bw. HC.	0,8
2002 b Reg. seat bw. C.	1,0
2002 c Reg. seat s.r. bw.	2,4
2004 a Reg. seat mill bw.	0,9
2004 b Reg. seat mill s.r. bw.	2,0
2005 a Reg. seat rev. HC.	0,7
2005 b Reg. seat rev. C.	0,8
2005 c Reg. seat rev. frh. HC.	1,1
2005 d Reg. seat rev. frh. C.	1,2
2011 a Steering with feet HC.	0,8
2011 b Steering with feet C.	0,9
2011 c Steering with feet frh. HC.	1,0
2011 d Steering with feet frh. C.	1,2
2012 a Lady seat HC.	0,7
2012 b Lady seat C.	0,8
2012 c Lady seat frh. HC.	1,1
2012 d Lady seat frh. C.	1,2
2013 a Lady seat bw. HC.	1,4
2013 b Lady seat bw. C.	1,5
2021 a Handlebarseat HC.	1,8
2021 b Handlebarseat C.	2,0
2021 c Handlebarseat frh. HC.	2,0
2021 d Handlebarseat frh. C.	2,2
2022 a Handlebarseat rev. HC.	0,9
2022 b Handlebarseat rev. C.	1,0
2022 c Handlebarseat rev. frh. HC.	1,3
2022 d Handlebarseat rev. frh. C.	1,5
2026 a Split HC.	0,7
2026 b Split C.	0,8
2026 c Split frh. HC.	1,1

UCI CYCLING REGULATIONS

Figure No. / Name of figure			Point value
2026	d	Split frh. C.	1,2
2027	a	Split rev. HC.	1,3
2027	b	Split rev. C.	1,5
2027	c	Split rev. frh. HC.	1,5
2027	d	Split rev. frh. C.	1,7
2031	a	Frontstand HC.	1,8
2031	b	Frontstand C.	2,0
2031	c	Frontstand frh. HC.	2,0
2031	d	Frontstand frh. C.	2,2
2036	a	Sidestand foot cranking HC.	0,9
2036	b	Sidestand foot cranking C.	1,0
2037	a	Sidestand HC.	0,8
2037	b	Sidestand C.	1,0
2037	c	Sidestand frh. HC.	1,2
2037	d	Sidestand frh. C.	1,4
2046	a	Stand on pins HC.	0,8
2046	b	Stand on pins C.	1,0
2046	c	Stand on pins frh. HC.	1,7
2046	d	Stand on pins frh. C.	1,9
2047	a	Stand bent on pin HC.	1,1
2047	b	Stand bent on pin C.	1,2
2047	c	Stand bent on pin frh. HC.	1,9
2047	d	Stand bent on pin frh. C.	2,1
2051	a	Bent knee seat HC.	1,2
2051	b	Bent knee seat C.	1,3
2052	a	Knee on saddle HC.	1,2
2052	b	Knee on saddle C.	1,3
2061	a	Lying on saddle HC.	1,1
2061	b	Lying on saddle C.	1,2
2061	c	Lying on saddle handlebar HC.	1,9
2061	d	Lying on saddle handlebar C.	2,1
2062	a	Waterscale under saddle HC.	1,5
2062	b	Waterscale under saddle C.	1,7
2062	c	Waterscale on saddle HC.	2,2
2062	d	Waterscale on saddle C.	2,4
2066	a	Framestand HC.	1,1
2066	b	Framestand frh. HC.	1,9
2066	c	Framestand frh. C.	2,1
2067	a	Saddle handlebarstand separate HC.	2,9
2067	b	Saddle handlebarstand separate C.	3,3
2067	c	Saddle handlebarstand HC.	2,9

UCI CYCLING REGULATIONS

Figure No. / Name of figure	Point value
2067 d Saddle handlebarstand C.	3,3
2067 e Saddle handlebarstand s.r.	3,9
2067 f Saddle handlebarstand count. 8	4,4
2068 a Saddle handlebarstand bw. separate HC.	5,8
2068 b Saddle handlebarstand bw. separate C.	6,4
2069 a Saddlestand separate HC.	4,2
2069 b Saddlestand separate C.	4,5
2069 c Saddlestand HC.	4,1
2069 d Saddlestand C.	4,3
2069 e Saddlestand s.r.	5,8
2069 f Saddlestand count. 8	6,7
2070 a Fronthandlebarstand separate HC.	3,7
2070 aa Fronthandlebarstand separate HC. out of regular seat	4,5
2070 b Fronthandlebarstand separate C.	3,9
2070 ba Fronthandlebarstand separate C. out of regular seat	4,7
2070 c Fronthandlebarstand HC.	3,7
2070 ca Fronthandlebarstand HC. out of regular seat	4,5
2070 d Fronthandlebarstand C.	3,9
2070 da Fronthandlebarstand C. out of regular seat	4,7
2070 e Fronthandlebarstand s.r.	4,8
2070 ea Fronthandlebarstand s.r. out of regular seat	5,6
2070 f Fronthandlebarstand count. 8	5,4
2070 fa Fronthandlebarstand count. 8 out of regular seat	6,2
2070 g Fronthandlebarstand ½ turn	6,8
2070 ga Fronthandlebarstand ½ turn out of regular seat	7,6
2070 h Fronthandlebarstand 1 turn T (8,0 - 8,5 - 9,0 - 9,5)	7,5
2070 ha Fronthandlebarstand 1 turn out of reg. seat T (8,8 - 9,3 - 9,8 - 10,3)	8,3
2070 i Fronthandlebarstand 1½ turns T (8,8 - 9,3 - 9,8 - 10,3)	8,3
2070 ia Fronthandlebarstand 1½ turns out of reg. seat T (9,6 - 10,1 - 10,6 - 11,1)	9,1
2070 j Fronthandlebarstand 2 turns T (9,5 - 10,0 - 10,5 - 11,0)	9,0
2070 ja Fronthandlebarstand 2 turns out of reg. seat T (10,3 - 10,8 - 11,3 - 11,8)	9,8
2070 k Count. C fronthandlebarstand ½ turn	6,5
2070 ka Count. C fronthandlebarstand ½ turn out of reg. seat	7,3
2070 l Count. C fronthandlebarstand 1 turn T (7,7 - 8,2 - 8,7 - 9,2)	7,2
2070 la Count. C fronthandlebarstand 1 turn out of reg. seat T (8,5 - 9,0 - 9,5 - 10,0)	8,0
2070 m Count. C fronthandlebarstand 1½ turns T (8,5 - 9,0 - 9,5 - 10,0)	8,0
2070 ma Count. C fronthandlebarstand 1½ turns out of regular seat T (9,3 - 9,8 - 10,3 - 10,8)	8,8
2070 n Count. C fronthandlebarstand 2 turns T (9,2 - 9,7 - 10,2 - 10,7)	8,7
2070 na Count. C fronthandlebarstand 2 turns out of regular seat T (10,0 - 10,5 - 11,0 - 11,5)	9,5

UCI CYCLING REGULATIONS

		Given			
Shown		2070g	2070h	2070i	2070j
		½	1	1 ½	2
	½	6,8			
	1		7,5		
	1½		8,0	8,3	
	2		8,5	8,8	9,0
	2½		9,0	9,3	9,5
	3		9,5	9,8	10,0
	3½			10,3	10,5
	4				11,0

		Given			
Shown		2070k	2070l	2070m	2070n
		½	1	1 ½	2
	½	6,5			
	1		7,2		
	1½		7,7	8,0	
	2		8,2	8,5	8,7
	2½		8,7	9,0	9,2
	3		9,2	9,5	9,7
	3½			10,0	10,2
	4				10,7

		Given			
Shown		2070ga	2070ha	2070ia	2070ja
		½	1	1 ½	2
	½	7,6			
	1		8,3		
	1½		8,8	9,1	
	2		9,3	9,6	9,8
	2½		9,8	10,1	10,3
	3		10,3	10,6	10,8
	3½			11,1	11,3
	4				11,8

		Given			
Shown		2070ka	2070la	2070ma	2070na
		½	1	1 ½	2
	½	7,3			
	1		8,0		
	1½		8,5	8,8	
	2		9,0	9,3	9,5
	2½		9,5	9,8	10,0
	3		10,0	10,3	10,5
	3½			10,8	11,0
	4				11,5

Figure No. / Name of figure	Point value
2071 a Handlebarstand rev. separate HC.	3,9
2071 b Handlebarstand rev. separate C.	4,1
2071 c Handlebarstand rev. HC.	3,9
2071 d Handlebarstand rev. C.	4,1
2071 e Handlebarstand rev. s.r.	5,0
2071 f Handlebarstand rev. count. 8	5,7
2073 a Headstand separate HC.	4,4
2073 b Headstand separate C.	4,6
2074 a Shoulderstand separate HC.	4,2
2074 b Shoulderstand separate C.	4,4
2076 a Saddle handlebar handstand separate HC.	9,2
2076 b Saddle handlebar handstand separate C.	9,6
2076 c Saddle handlebar handstand count. 8	11,4
2076 d L-shape hold sdw. saddle handlebar handstand separate HC. T (12,0 - 12,6)	10,8
2076 e L-shape hold sdw. saddle handlebar handstand separate C. T (12,4 - 13,0)	11,2
2076 f L-shape hold sdw. saddle handlebar handstand count. 8 T (14,2 - 14,8)	13,0

UCI CYCLING REGULATIONS

Figure No. / Name of figure	Point value
2076 g L-shape hold sdw. swiss saddle handlebar handstand separate HC.	12,6
2076 h L-shape hold sdw. swiss saddle handlebar handstand separate C.	13,0
2076 i L-shape hold sdw. swiss saddle handlebar handstand count. 8	14,8
2076 j L-shape hold sdw. german saddle handlebar handstand separate HC.	13,2
2076 k L-shape hold sdw. german saddle handlebar handstand separate C.	13,6
2076 l L-shape hold sdw. german saddle handlebar handstand count. 8	15,4

		Given		
Shown		2076d	2076e	2076f
	2076g	12,0		
	2076h		12,4	
	2076i			14,2
	2076j	12,6		
	2076k		13,0	
	2076l			14,8

Figure No. / Name of figure	Point value
2077 a Handlebar handstand separate HC.	9,1
2077 b Handlebar handstand separate C.	9,5
2077 c Handlebar handstand count. 8	11,3
2077 d L-shape hold handlebar handstand separate HC. T (11,9 - 12,5)	10,7
2077 e L-shape hold handlebar handstand separate C. T (12,3 - 12,9)	11,1
2077 f L-shape hold handlebar handstand count. 8 T (14,1 - 14,7)	12,9
2077 g L-shape hold swiss handlebar handstand separate HC.	12,5
2077 h L-shape hold swiss handlebar handstand separate C.	12,9
2077 i L-shape hold swiss handlebar handstand count.8	14,7
2077 j L-shape hold german handlebar handstand separate HC.	13,1
2077 k L-shape hold german handlebar handstand separate C.	13,5
2077 l L-shape hold german handlebar handstand count. 8	15,3

		Given		
Shown		2077d	2077e	2077f
	2077g	11,9		
	2077h		12,3	
	2076i			14,1
	2076j	12,5		
	2076k		12,9	
	2076l			14,7

Figure No. / Name of figure	Point value
2081 a Maute jump separate	10,2
2091 a Stillstand on pedals	0,8
2091 b Stillstand on pedals frh.	1,2

2091	c	Stillstand pedal frontwheel	1,1
2091	d	Stillstand pedal frontwheel frh.	1,6

(text modified on 01.01.12; 01.01.16)

8.6.003 Raiser figures on two bicycles

Figure No. / Name of figure			Point value
2131	a	Raiser reg. seat HC.	1,5
2131	b	Raiser reg. seat C.	1,7
2131	c	Raiser reg. seat frh. HC.	1,9
2131	d	Raiser reg. seat frh. C.	2,1
2131	e	Raiser reg. seat s.r.	3,1
2131	f	Raiser reg. seat s.r. frh.	3,6
2132	a	Raiser reg. seat bw. frh. HC.	2,3
2132	b	Raiser reg. seat bw. frh. C.	2,5
2132	c	Raiser reg. seat s.r. bw. frh.	4,5
2133	a	Raiser reg. seat mill	1,6
2133	b	Raiser reg. seat mill frh.	2,0
2133	c	Raiser reg. seat mill s.r.	2,7
2133	d	Raiser reg. seat mill s.r. frh.	3,3
2134	a	Raiser reg. seat mill bw. frh.	2,3
2134	b	Raiser reg. seat mill bw. s.r. frh.	4,1
2134	c	Raiser reg. seat mill spin. bw. frh.	5,5
2135	a	Raiser reg. seat rev. frh. HC.	2,3
2135	b	Raiser reg. seat rev. frh. C.	2,5
2135	c	Raiser reg. seat rev. s.r. frh.	4,7
2136	a	Raiser reg. seat rev. bw. frh. HC.	2,9
2136	b	Raiser reg. seat rev. bw. frh. C.	3,1
2136	c	Raiser reg. seat rev. s.r. bw. frh.	5,7
2137	a	Raiser reg. seat rev. mill frh.	2,4
2137	b	Raiser reg. seat rev. mill s.r. frh.	4,3
2137	c	Raiser reg. seat rev. mill spin. frh.	6,0
2138	a	Raiser reg. seat rev. mill bw. frh.	2,9
2138	b	Raiser reg. seat rev. mill s.r. bw. frh.	5,3
2147	a	Raiser lady seat s.r. bw. frh.	6,6
2151	a	Raiser stand on pin HC.	2,2
2151	b	Raiser stand on pin C.	2,4
2152	a	Raiser stand on pin s.r. bw.	5,4
2154	a	Raiser stand on pin mill s.r. bw.	5,0
2161	a	Raiser handlebarseat HC.	1,7
2161	b	Raiser handlebarseat C.	1,9

UCI CYCLING REGULATIONS

Figure No. / Name of figure	Point value
2161 c Raiser handlebarseat frh. HC.	2,1
2161 d Raiser handlebarseat frh. C.	2,3
2161 e Raiser handlebarseat s.r. frh.	3,8
2162 a Raiser handlebarseat bw. frh. HC.	2,5
2162 b Raiser handlebarseat bw. frh. C.	2,7
2162 c Raiser handlebarseat s.r. bw. frh.	4,7
2163 a Raiser handlebarseat mill	1,8
2163 b Raiser handlebarseat mill frh.	2,2
2163 c Raiser handlebarseat mill s.r. frh.	3,4
2164 a Raiser handlebarseat mill bw. frh.	2,9
2164 b Raiser handlebarseat mill s.r. bw. frh.	4,3
2164 c Raiser handlebarseat mill spin. bw. frh.	5,5
2165 a Raiser handlebarseat rev. frh. HC.	2,3
2165 b Raiser handlebarseat rev. frh. C.	2,5
2165 c Raiser handlebarseat rev. s.r. frh.	4,4
2166 a Raiser handlebarseat rev. bw. frh. HC.	2,8
2166 b Raiser handlebarseat rev. bw. frh. C.	3,0
2166 c Raiser handlebarseat rev. s.r. bw. frh.	5,0
2167 a Raiser handlebarseat rev. mill frh.	2,4
2167 b Raiser handlebarseat rev. mill s.r. frh.	4,0
2167 c Raiser handlebarseat rev. mill spin. frh.	5,6
2168 a Raiser handlebarseat rev. mill bw. frh.	3,2
2168 b Raiser handlebarseat rev. mill s.r. bw. frh.	4,8
2176 a Raiser headtube frh. HC.	1,6
2176 b Raiser headtube frh. C.	1,8
2176 c Raiser headtube s.r. frh.	3,2
2177 a Raiser headtube bw. frh. HC.	2,1
2177 b Raiser headtube bw. frh. C.	2,3
2177 c Raiser headtube s.r. bw. frh.	4,1
2178 a Raiser headtube mill frh.	1,8
2178 b Raiser headtube mill s.r. frh.	2,7
2179 a Raiser headtube mill bw. frh.	2,1
2179 b Raiser headtube mill s.r. bw. frh.	3,7
2179 c Raiser headtube mill spin. bw. frh.	5,0
2180 a Raiser headtube rev. frh. HC.	2,4
2180 b Raiser headtube rev. frh. C.	2,6
2180 c Raiser headtube rev. s.r. frh.	4,2
2181 a Raiser headtube rev. bw. frh. HC.	2,9
2181 b Raiser headtube rev. bw. frh. C.	3,1
2181 c Raiser headtube rev. s.r. bw. frh.	5,1

UCI CYCLING REGULATIONS

Figure No. / Name of figure	Point value
2182 a Raiser headtube rev. mill frh.	2,5
2182 b Raiser headtube rev. mill s.r. frh.	3,8
2182 c Raiser headtube rev. mill spin. frh.	5,9
2183 a Raiser headtube rev. mill bw. frh.	3,0
2183 b Raiser headtube rev. mill s.r. bw. frh.	4,7
2191 a Standraiser HC.	2,6
2191 b Standraiser C.	2,8
2191 c Standraiser s.r.	4,4
2192 a Standraiser bw. HC.	2,9
2192 b Standraiser bw. C.	3,1
2192 c Standraiser s.r. bw.	4,9
2193 a Standraiser mill	2,7
2193 b Standraiser mill s.r.	4,0
2194 a Standraiser mill bw.	2,9
2194 b Standraiser mill s.r. bw.	4,5
2194 c Standraiser mill spin. bw.	5,9
2195 a Standraiser rev. HC.	2,9
2195 b Standraiser rev. C.	3,1
2195 c Standraiser rev. s.r.	4,7
2196 a Standraiser rev. bw. HC.	3,2
2196 b Standraiser rev. bw. C.	3,4
2196 c Standraiser s.r. bw.	5,4
2197 a Standraiser rev. mill	3,0
2197 b Standraiser rev. mill s.r.	4,3
2197 c Standraiser rev. mill spin.	6,3
2198 a Standraiser rev. mill bw.	3,2
2198 b Standraiser rev. mill s.r. bw.	5,0

8.6.004 Turns on the spot on two bicycles

Figure No. / Name of figure	Point value
2211 a Raiser handlebarseat 1 turn	4,6
2211 b Raiser handlebarseat 2 turns T (6,8 - 7,3)	6,3
2211 c Raiser handlebarseat 3 turns T (7,8)	7,2
2212 a Raiser handlebarseat rev. 1 turn	4,9
2212 b Raiser handlebarseat rev. 2 turns T (7,0 - 7,5)	6,5
2212 c Raiser handlebarseat rev. 3 turns T (8,1)	7,5
2213 a Raiser headtube 1 turn	4,4
2213 b Raiser headtube 2 turns T (6,5 - 7,0)	6,0
2213 c Raiser headtube 3 turns T (7,6)	7,0

UCI CYCLING REGULATIONS

Figure No. / Name of figure	Point value
2214 a Raiser headtube rev. 1 turn	4,9
2214 b Raiser headtube rev. 2 turns T (7,0 - 7,5)	6,5
2214 c Raiser headtube rev. 3 turns T (8,1)	7,5
2215 a Standraiser 1 turn	5,2
2215 b Standraiser 2 turns T (7,4 - 7,9)	6,9
2215 c Standraiser 3 turns T (8,4)	7,8
2216 a Standraiser rev. 1 turn	5,5
2216 b Standraiser rev. 2 turns T (7,7 - 8,2)	7,2
2216 c Standraiser rev. 3 turns T (8,7)	8,1

(text modified 01.01.12)

8.6.005 Passages on two bicycles

Figure No. / Name of figure	Point value
2236 a P. raiser reg. seat raiser handlebarseat	1,9
2236 b P. raiser handlebarseat raiser reg. seat	1,9
2237 a P. raiser reg. seat raiser headtube	2,9
2237 b P. raiser headtube raiser reg. seat	2,9
2238 a P. raiser handlebarseat raiser headtube	2,4
2238 b P. raiser headtube raiser handlebarseat	2,4
2239 a P. raiser headtube standraiser rev.	2,1
2239 b P. standraiser rev. raiser headtube	2,1
2240 a P. standraiser raiser headtube rev.	2,1
2240 b P. raiser headtube rev. standraiser	2,2
2241 a P. raiser headtube rev. raiser handlebarseat rev.	3,4
2241 b P. raiser handlebarseat rev. raiser headtube rev.	3,5
2242 a P. backhang standraiser separate	5,7
2243 a P. backhang raiser headtube rev. separate	4,6

(text modified on 01.01.17)

8.6.006 Final figures on two bicycles

Figure No. / Name of figure	Point value
2250 a Handlebarstand rev. somersault bw. hooked legs	12,1

(text modified on 01.01.16)

8.6.007 Figures on one bicycle

Figure No. / Name of figure	Point value
2261 a Reg. seat / Stand on pins HC.	0,3

UCI CYCLING REGULATIONS

Figure No. / Name of figure	Point value
2261 b Reg. seat / Stand on pins C.	0,4
2261 c Reg. seat / Saddlestand HC.	0,7
2261 d Reg. seat / Saddlestand C.	0,9
2266 a Reg. seat / Shoulderseat HC.	0,7
2266 b Reg. seat / Shoulderseat C.	0,9
2266 c Reg. seat frh. / Shoulderseat HC.	1,6
2266 d Reg. seat frh. / Shoulderseat C.	1,9
2267 a Reg. seat bw. / Shoulderseat HC.	1,9
2267 b Reg. seat bw. / Shoulderseat C.	2,2
2268 a Reg. seat / Shoulderstand HC.	2,0
2268 b Reg. seat / Shoulderstand C.	2,3
2268 c Reg. seat frh. / Shoulderstand HC.	3,0
2268 d Reg. seat frh. / Shoulderstand C.	3,4
2269 a Reg. seat bw. / Shoulderstand HC.	3,7
2269 b Reg. seat bw. / Shoulderstand C.	4,1
2270 a Reg. seat / Chest suspended hang HC.	1,3
2270 b Reg. seat / Chest suspended hang C.	1,5
2270 c Reg. seat frh. / Chest suspended hang HC.	2,1
2270 d Reg. seat frh. / Chest suspended hang C.	2,4
2271 a Reg. seat bw. / Chest suspended hang HC.	2,3
2271 b Reg. seat bw. / Chest suspended hang C.	2,6
2276 a Reg. seat / Handlebarstand HC.	1,2
2276 b Reg. seat / Handlebarstand C.	1,3
2277 a Reg. seat / Handlebar handstand HC.	5,5
2277 b Reg. seat / Handlebar handstand C.	5,9
2281 a Reg. seat rev. / Shoulderseat HC.	1,1
2281 b Reg. seat rev. / Shoulderseat C.	1,3
2282 a Reg. seat rev. bw. / Shoulderseat HC.	1,9
2282 b Reg. seat rev. bw. / Shoulderseat C.	2,1
2283 a Reg. seat rev. / Shoulderstand HC.	2,7
2283 b Reg. seat rev. / Shoulderstand C.	3,0
2285 a Reg. seat rev. / Chest suspended hang HC.	1,7
2285 b Reg. seat rev. / Chest suspended hang C.	1,9
2286 a Reg. seat rev. bw. / Chest suspended hang HC.	2,5
2286 b Reg. seat rev. bw. / Chest suspended hang C.	2,7
2296 a Handlebarseat / Stand on pins HC.	1,1
2296 b Handlebarseat / Stand on pins C.	1,2
2296 c Handlebarseat frh. / Stand on pins HC.	1,6
2296 d Handlebarseat frh. / Stand on pins C.	1,8
2296 e Handlebarseat / Saddlestand HC.	1,8

UCI CYCLING REGULATIONS

Figure No. / Name of figure	Point value
2296 f Handlebarseat / Saddlestand C.	2,0
2296 g Handlebarseat frh. / Saddlestand HC.	2,3
2296 h Handlebarseat frh. / Saddlestand C.	2,5
2301 a Handlebarseat rev. / Stand on pins HC.	0,8
2301 b Handlebarseat rev. / Stand on pins C.	0,9
2301 c Handlebarseat rev. frh. / Stand on pins HC.	1,3
2301 d Handlebarseat rev. frh. / Stand on pins C.	1,4
2302 a Handlebarseat rev. / Saddle handlebarstand HC.	1,3
2302 b Handlebarseat rev. / Saddle handlebarstand C.	1,4
2302 c Handlebarseat rev. frh. / Saddle handlebarstand HC.	1,8
2302 d Handlebarseat rev. frh. / Saddle handlebarstand C.	1,9
2302 e Handlebarseat rev. / Saddlestand HC.	1,4
2302 f Handlebarseat rev. / Saddlestand C.	1,7
2302 g Handlebarseat rev. frh. / Saddlestand HC.	2,0
2302 h Handlebarseat rev. frh. / Saddlestand C.	2,3
2303 a Handlebarseat rev. / Shoulderseat HC.	1,3
2303 b Handlebarseat rev. / Shoulderseat C.	1,5
2303 c Handlebarseat rev. frh. / Shoulderseat HC.	1,9
2303 d Handlebarseat rev. frh. / Shoulderseat C.	2,2
2304 a Handlebarseat rev. / Shoulderstand HC.	2,9
2304 b Handlebarseat rev. / Shoulderstand C.	3,2
2304 c Handlebarseat rev. frh. / Shoulderstand HC.	3,6
2304 d Handlebarseat rev. frh. / Shoulderstand C.	3,9
2305 a Handlebarseat rev. / Chest suspended hang HC.	1,8
2305 b Handlebarseat rev. / Chest suspended hang C.	2,0
2305 c Handlebarseat rev. frh. / Chest suspended hang HC.	2,4
2305 d Handlebarseat rev. frh. / Chest suspended hang C.	2,6
2306 a Handlebarseat rev. / Headstand HC.	2,7
2306 b Handlebarseat rev. / Headstand C.	2,9
2311 a Frontstand / Stand on pins HC.	0,9
2311 b Frontstand / Stand on pins C.	1,0
2311 c Frontstand frh. / Stand on pins HC.	1,4
2311 d Frontstand frh. / Stand on pins C.	1,6
2311 e Frontstand / Saddlestand HC.	1,6
2311 f Frontstand / Saddlestand C.	1,8
2311 g Frontstand frh. / Saddlestand HC.	2,1
2311 h Frontstand frh. / Saddlestand C.	2,3
2316 a Split / Shoulderseat HC.	1,0
2316 b Split / Shoulderseat C.	1,2
2316 c Split frh. / Shoulderseat HC.	1,6
2316 d Split frh. / Shoulderseat C.	1,8
2317 a Sidestand / Sidestand ring grip HC.	1,4
2317 b Sidestand / Sidestand ring grip C.	1,6

UCI CYCLING REGULATIONS

Figure No. / Name of figure	Point value
2319 a Stand bent on saddle / Stand bent on handlebar rev. HC.	1,8
2319 b Stand bent on saddle / Stand bent on handlebar rev. C.	2,0
2321 a Frameseat / Stand bent on saddle HC.	1,1
2321 b Frameseat / Stand bent on saddle C.	1,2
2322 a Frameseat / Saddle handlebarstand HC.	1,5
2322 b Frameseat / Saddle handlebarstand C.	1,7
2322 c Frameseat / Saddlestand HC.	1,8
2322 d Frameseat / Saddlestand C.	2,0
2323 a Frameseat / Saddle support scale HC.	2,4
2323 b Frameseat / Saddle support scale C.	2,8
2331 a Fronthang / Stand bent on saddle HC.	1,0
2331 b Fronthang / Stand bent on saddle C.	1,2
2332 a Fronthang / Saddle handlebarstand HC.	1,5
2332 b Fronthang / Saddle handlebarstand C.	1,7
2332 c Fronthang / Saddlestand HC.	1,8
2332 d Fronthang / Saddlestand C.	2,0
2334 a Fronthang / Headstand HC.	2,8
2334 b Fronthang / Headstand C.	3,0
2334 c Fronthang / Saddle handlebar handstand HC.	6,6
2334 d Fronthang / Saddle handlebar handstand C.	7,0
2341 a Backhang / Stand on pins HC.	0,9
2341 b Backhang / Stand on pins C.	1,0
2342 a Backhang / Saddle handlebarstand HC.	1,4
2342 b Backhang / Saddle handlebarstand C.	1,5
2342 c Backhang / Saddlestand HC.	1,7
2342 d Backhang / Saddlestand C.	1,9
2343 a Backhang / Handlebarstand HC.	1,8
2343 b Backhang / Handlebarstand C.	1,9
2346 a Backhang / Headstand HC.	2,7
2346 b Backhang / Headstand C.	2,9
2346 c Backhang / Saddle handlebar handstand HC.	6,6
2346 d Backhang / Saddle handlebar handstand C.	7,0
2351 a Lying on handlebar / Stand bent on saddle HC.	1,3
2351 b Lying on handlebar / Stand bent on saddle C.	1,5
2351 c Lying on handlebar / Saddlestand HC.	2,2
2351 d Lying on handlebar / Saddlestand C.	2,4
2352 a Lying on saddle / Handlebarstand HC.	1,9
2352 b Lying on saddle / Handlebarstand C.	2,0
2352 c Lying on saddle / Handlebar handstand HC.	6,0
2352 d Lying on saddle / Handlebar handstand C.	6,4

UCI CYCLING REGULATIONS

Figure No. / Name of figure	Point value
2353 a Waterscale / Stand bent on saddle HC.	1,5
2353 b Waterscale / Stand bent on saddle C.	1,6
2353 c Waterscale / Saddlestand HC.	2,2
2353 d Waterscale / Saddlestand C.	2,4
2356 a Saddle handlebarstand / Saddle handlebarstand HC.	3,0
2356 b Saddle handlebarstand / Saddle handlebarstand C.	3,2
2356 c Saddle handlebarstand / Saddle handlebarstand S	3,6
2356 d Saddle handlebarstand / Saddle handlebarstand 8	4,1
2357 a Saddle handlebarstand / Stand on pins HC.	2,5
2357 b Saddle handlebarstand / Stand on pins C.	2,6
2357 c Saddle handlebarstand / Saddlestand HC.	3,1
2357 d Saddle handlebarstand / Saddlestand C.	3,2
2357 e Saddle handlebarstand / Handlebarstand HC.	3,7
2357 f Saddle handlebarstand / Handlebarstand C.	3,8
2358 a Handlebarstand / Stand on pins HC.	3,2
2358 b Handlebarstand / Stand on pins C.	3,4
2358 c Handlebarstand ½ turn / Stand on pins	5,9
2358 d Handlebarstand 1 turn / Stand on pins T (7,2 - 7,7 - 8,2 - 8,7)	6,7
2358 e Handlebarstand 1½ turns / Stand on pins T (8,0 - 8,5 - 9,0 - 9,5)	7,5
2358 f Handlebarstand 2 turns / Stand on pins T (8,8 - 9,3 - 9,8 - 10,3)	8,3
2358 g Handlebarstand out of reg. seat / Stand on pins HC.	4,0
2358 h Handlebarstand out of reg. seat / Stand on pins C.	4,1
2358 i Handlebarstand ½ turn out of reg. seat / Stand on pins	6,7
2358 j Handlebarstand 1 turn out of reg. seat / Stand on pins T (8,0 - 8,5 - 9,0 - 9,5)	7,5
2358 k Handlebarstand 1½ turns out of reg. seat / Stand on pins T (8,8 - 9,3 - 9,8 - 10,3)	8,3
2358 l Handlebarstand 2 turns out of reg. seat / Stand on pins T (9,6 - 10,1 - 10,6 - 11,1)	9,1

		Given			
		2358c	2358d	2358e	2358f
Shown		½	1	1 ½	2
	½	5,9			
	1		6,7		
	1½		7,2	7,5	
	2		7,7	8,0	8,3
	2½		8,2	8,5	8,8
	3		8,7	9,0	9,3
	3½			9,5	9,8
	4				10,3

		Given			
		2358i	2358j	2358k	2358l
Shown		½	1	1 ½	2
	½	6,7			
	1		7,5		
	1½		8,0	8,3	
	2		8,5	8,8	9,1
	2½		9,0	9,3	9,6
	3		9,5	9,8	10,1
	3½			10,3	10,6
	4				11,1

Figure No. / Name of figure	Point value
2359 a Handlebarstand / Saddlestand ring grip HC.	3,6
2359 b Handlebarstand / Saddlestand ring grip C.	3,7
2359 c Handlebarstand / Saddlestand HC.	4,9
2359 d Handlebarstand / Saddlestand C.	5,1

UCI CYCLING REGULATIONS

Figure No. / Name of figure	Point value
2359 e Handlebarstand / Saddlestand S	5,6
2359 f Handlebarstand / Saddlestand 8	6,1
2366 a Handlebar L-shape hold / Stand on pins HC.	3,0
2366 b Handlebar L-shape hold / Stand on pins C.	3,5
2366 c Handlebar L-shape hold / Saddlestand HC.	3,8
2366 d Handlebar L-shape hold / Saddlestand C.	4,2
2366 e Handlebar L-shape hold / Saddle support straddle HC.	5,0
2366 f Handlebar L-shape hold / Saddle support straddle C.	5,4
2366 g Handlebar support straddle / Saddle support straddle HC.	6,0
2366 h Handlebar support straddle / Saddle support straddle C.	6,4
2371 a Headstand / Handlebarstand HC.	3,8
2371 b Headstand / Handlebarstand C.	4,1
2372 a Headstand / Frame shoulderstand HC.	5,1
2372 b Headstand / Frame shoulderstand C.	5,5
2373 a Headstand / Handlebar support straddle HC.	6,1
2373 b Headstand / Handlebar support straddle C.	6,5
2374 a Headstand / Handlebar handstand HC.	8,5
2374 b Headstand / Handlebar handstand C.	9,0
2374 c Headstand / Handlebar handstand S	9,8
2374 d Headstand / Handlebar handstand 8	10,6
2374 e Headstand / Handlebar support straddle handlebar handstand HC.	11,0
2374 f Headstand / Handlebar support straddle handlebar handstand C.	11,5
2374 g Headstand / Handlebar support straddle handlebar handstand S	12,3
2374 h Headstand / Handlebar support straddle handlebar handstand 8	13,1
2376 a Saddle handlebar handstand / Handlebarstand HC.	7,7
2376 b Saddle handlebar handstand / Handlebarstand C.	8,1
2376 c Handlebar handstand / Saddlestand HC.	7,6
2376 d Handlebar handstand / Saddlestand C.	8,0
2377 a Handlebar handstand / Saddle handlebar handstand HC.	10,6
2377 b Handlebar handstand / Saddle handlebar handstand C.	11,0
2391 a Stillstand on pedals / Shoulderseat	1,3
2391 b Stillstand on pedals frh. / Shoulderseat	1,8
2391 c Stillstand on pedals / Shoulderstand	2,7
2391 d Stillstand on pedals frh. / Shoulderstand	3,2

(text modified on 01.01.16)

8.6.008 Raiser figures on one bicycle

Figure No. / Name of figure	Point value
2411 a Raiser reg. seat / Stand on pins HC.	2,2
2411 b Raiser reg. seat / Stand on pins C.	2,4
2412 a Raiser reg. seat / Shoulderseat HC.	2,9

UCI CYCLING REGULATIONS

Figure No. / Name of figure	Point value
2412 b Raiser reg. seat / Shoulderseat C.	3,1
2412 c Raiser reg. seat frh. / Shoulderseat HC.	3,5
2412 d Raiser reg. seat frh. / Shoulderseat C.	3,8
2413 a Raiser reg. seat bw. frh. / Shoulderseat HC.	4,1
2413 b Raiser reg. seat bw. frh. / Shoulderseat C.	4,4
2413 c Raiser reg. seat spin. bw. frh. / Shoulderseat	6,1
2414 a Raiser reg. seat / Chest suspended hang HC.	3,1
2414 b Raiser reg. seat / Chest suspended hang C.	3,3
2414 c Raiser reg. seat frh. / Chest suspended hang HC.	3,8
2414 d Raiser reg. seat frh. / Chest suspended hang C.	4,2
2415 a Raiser reg. seat bw. frh. / Chest suspended hang HC.	4,4
2415 b Raiser reg. seat bw. frh. / Chest suspended hang C.	4,6
2416 a Raiser reg. seat / Shoulderstand HC.	4,8
2416 b Raiser reg. seat / Shoulderstand C.	5,1
2416 c Raiser reg. seat frh. / Shoulderstand HC.	5,6
2416 d Raiser reg. seat frh. / Shoulderstand C.	6,0
2417 a Raiser reg. seat bw. frh. / Shoulderstand HC.	6,5
2417 b Raiser reg. seat bw. frh. / Shoulderstand C.	7,0
2418 a Raiser reg. seat rev. frh. / Shoulderseat HC.	3,9
2418 b Raiser reg. seat rev. frh. / Shoulderseat C.	4,3
2418 c Raiser reg. seat rev. spin. frh. / Shoulderseat	6,5
2419 a Raiser reg. seat rev. bw. frh. / Shoulderseat HC.	4,9
2419 b Raiser reg. seat rev. bw. frh. / Shoulderseat C.	5,3
2420 a Raiser reg. seat rev. frh. / Chest suspended hang HC.	4,1
2420 b Raiser reg. seat rev. frh. / Chest suspended hang C.	4,5
2421 a Raiser reg. seat rev. bw. frh. / Chest suspended hang HC.	5,1
2421 b Raiser reg. seat rev. bw. frh. / Chest suspended hang C.	5,5
2422 a Raiser reg. seat rev. frh. / Shoulderstand HC.	6,7
2422 b Raiser reg. seat rev. frh. / Shoulderstand C.	7,1
2426 a Raiser handlebarseat / Shoulderseat HC.	3,4
2426 b Raiser handlebarseat / Shoulderseat C.	3,7
2426 c Raiser handlebarseat frh. / Shoulderseat HC.	4,0
2426 d Raiser handlebarseat frh. / Shoulderseat C.	4,4
2427 a Raiser handlebarseat bw. frh. / Shoulderseat HC.	4,7
2427 b Raiser handlebarseat bw. frh. / Shoulderseat C.	5,0
2427 c Raiser handlebarseat spin. bw. frh. / Shoulderseat	6,9
2428 a Raiser handlebarseat / Shoulderstand HC.	5,5
2428 b Raiser handlebarseat / Shoulderstand C.	5,9
2428 c Raiser handlebarseat frh. / Shoulderstand HC.	6,3
2428 d Raiser handlebarseat frh. / Shoulderstand C.	6,7

UCI CYCLING REGULATIONS

Figure No. / Name of figure	Point value
2429 a Raiser handlebarseat bw. frh. / Shoulderstand HC.	7,4
2429 b Raiser handlebarseat bw. frh. / Shoulderstand C.	8,0
2436 a Raiser headtube frh. / Shoulderseat HC.	3,6
2436 b Raiser headtube frh. / Shoulderseat C.	4,0
2437 a Raiser headtube bw. frh. / Shoulderseat HC.	4,2
2437 b Raiser headtube bw. frh. / Shoulderseat C.	4,6
2437 c Raiser headtube spin. bw. frh. / Shoulderseat	6,4
2438 a Raiser headtube frh. / Shoulderstand HC.	6,0
2438 b Raiser headtube frh. / Shoulderstand C.	6,4
2439 a Raiser headtube bw. frh. / Shoulderstand HC.	7,0
2439 b Raiser headtube bw. frh. / Shoulderstand C.	7,6
2446 a Raiser headtube rev. frh. / Shoulderseat HC.	4,3
2446 b Raiser headtube rev. frh. / Shoulderseat C.	4,7
2446 c Raiser headtube rev. spin. frh. / Shoulderseat	7,0
2447 a Raiser headtube rev. bw. frh. / Shoulderseat HC.	5,3
2447 b Raiser headtube rev. bw. frh. / Shoulderseat C.	5,7
2448 a Raiser headtube rev. frh. / Shoulderstand HC.	6,4
2448 b Raiser headtube rev. frh. / Shoulderstand C.	6,8
2449 a Raiser headtube rev. bw. frh. / Shoulderstand HC.	7,9
2449 b Raiser headtube rev. bw. frh. / Shoulderstand C.	8,5

8.6.009 Passages on one bicycle

Figure No. / Name of figure	Point value
2471 a P. raiser reg. seat raiser handlebarseat / Shoulderseat	4,8
2471 b P. raiser reg. seat raiser handlebarseat / Shoulderstand	6,7
2472 a P. raiser reg. seat raiser headtube / Shoulderseat	7,0
2472 b P. raiser reg. seat raiser headtube / Shoulderstand	9,7
2473 a P. raiser handlebarseat raiser headtube / Shoulderseat	5,9
2473 b P. raiser handlebarseat raiser headtube / Shoulderstand	8,2

Chapter VII EXPLANATIONS OF FIGURES PAIR ARTISTIC CYCLING

8.7.001 Figures with both wheels on floor on two bicycles

Reg. seat

Regular seat on saddle, both feet on ~~each~~ **a the** pedals.
Chest directed to handlebar.



2001
2002
2003
2004

Reg. seat rev.

Reversed seat on saddle, both feet on ~~each~~ **a the** pedals.
Back directed to handlebar.



2005

Steering with feet

Regular seat on saddle, both feet on handlebar.



2011

Lady seat

Regular seat on saddle, one foot on pedal. The free leg must be stretched over the top tube to the opposite side of the bicycle and below the handlebar. The handlebar may not be touched by the leg or foot.



2012
2013

Handlebarseat

Seat on handlebar, back directed to the saddle. The free leg must be stretched forward, horizontally. Other foot hooked to the down tube.



2021

Handlebarseat rev.

Reversed seat on handlebar, both feet each on a pedal.
Chest directed to the saddle.



2022

Split

Left foot standing on left rear-pin, right foot standing on right front-pin (or counterwise). Chest directed to the handlebar. The handlebar may not be touched with the leg.



2026

Split rev.

Right foot standing on the left rear-pin, left foot standing on the right-frontpin (or counterwise). Chest directed to the saddle. The handlebar may not be touched with the leg.



2027

Frontstand

Stand in front of the handlebar, back directed to the saddle. One foot on frontpin, other foot hooked to the down tube.



2031

Sidestand foot cranking

One foot standing on left rear-pin, other foot on left pedal (or counterwise). Chest directed to the handlebar.



2036

Sidestand

Stand with one foot on left rear-pin, other foot on left front-pin (or counterwise). Chest directed to the handlebar. The handlebar may not be touched with the leg.



2037

Stand on pins

Standing with both feet each on a rear-pin. Both knees behind the saddle



2046

Stand bent on pin

One foot standing on rear-pin, trunk bent forward, free leg stretched to the back in straight line with the trunk.



2047

Bent knee seat

In squat position with one foot on top tube, free leg horizontally stretched forward, back directed to the saddle.

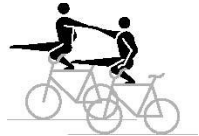

2051

Knee on saddle

Knee on saddle, trunk bent forward, free leg stretched to the back in straight line with the trunk.



2052

Lying on saddle; Lying on saddle and handlebar

a-b: Lying with front of body on the saddle, closed stretched legs to the back.

c-d: Lying with front of body on saddle, arms stretched sideways free-hand on handlebar-grips. Closed legs stretched horizontally to the back.

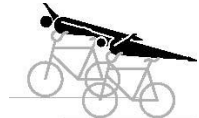

2061

Waterscale

Lying with back of body in a straight line on the handlebar, stretched legs or feet under (a and b), or on (c and d) the saddle.

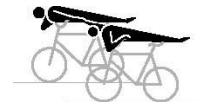

2062

Framestand

Standing upright with one foot standing on the down tube, other foot standing on the saddle tube. Chest directed to handlebar. Feet may not touch each other, legs may not touch the handlebar.



2066

Saddle handlebarstand

Standing free, upright stretched with one foot on saddle and the other foot on the handlebar.



2067

2068

Saddlestand

Standing free, upright stretched with both feet on saddle.



2069

Fronthandlebarstand, Fronthandlebarstand turn (T)

From one turn of the tactical enlargement of the fronthandlebarstand turn(s) is possible up to four half turns in maximum.

a-f: Standing free, upright with both feet on handlebar-grips, back directed to the saddle.

g-j: From fronthandlebarstand **after releasing grip connection** with half or multiple front wheel turn(s) to fronthandlebarstand or handlebarstand reverse. After **completion of** the last **handlebarstand** turn, the **handlebarstand end-position** must be held for at least 2 metres **in grip connection**.

aa-ja: The riders jump **simultaneously** from regular seat to fronthandlebarstand; further execution according **to** the figure **a-e; g-j**.



2070

Counter circle fronthandlebarstand (T)

k-n: From fronthandlebarstand with half or multiple front wheel turn(s) to fronthandlebarstand or handlebarstand reverse. Execution of the figure according **to** the guidelines for counter circle. After **completion of** the last **handlebarstand** turn, but before the required hand touch, **at the end of the figure** the **handlebarstand end-position** must be held for at least 2 metres.

ka-na: The riders jump **simultaneously** from regular seat to fronthandlebarstand; further execution according **to** the figure **k-n**.

2070 k
2070 l
2070 m
2070 n

Handlebarstand rev.

Standing, reversed, free, upright stretched with both feet on handle-bar-grips, chest directed to the saddle.



2071

Headstand

Separate performed headstand on the saddle, both hands on the handlebar. Legs closed and **vertically** stretched **straight upwards**.



2073

Shoulderstand

Separate performed shoulderstand with one shoulder on saddle or top tube, both hands on the handlebar. Legs closed and **vertically** stretched **straight upwards**.



2074

Saddle handlebar handstand

Separate performed handstand with one hand on handlebar and other hand on saddle. Arms stretched, legs closed and **vertically** stretched **straight upwards**. The forearm or the wrist may not be leaned against the handlebar-grip.

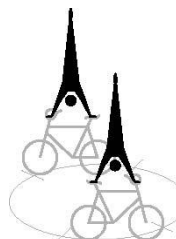

2076 a
2076 b
2076 c

L-shape hold sideways saddle handlebar handstand (T)

2076 d
2076 e
2076 f

From the L-shape hold sideways, which has to be performed for at least 2 metres, going directly to the handstand without touching the frame with foot/feet. The handstand must be performed as described in the figures **2076a-c** and held through the whole way of stretch.

The tactical enlargement is possible for the kind of execution as Swiss saddle handlebar handstand, which has to be performed like the figures **2076g-i**. The tactical enlargement is possible for the kind of execution as German saddle handlebar handstand, which has to be performed like the figures **2076j-l**.

L-shape hold sideways Swiss saddle handlebar handstand

2076 g
2076 h
2076 i

From the L-shape hold sideways, which has to be performed for at least 2 metres, going directly to handstand with stretched legs over the frame but without touching the frame and/or handlebar with foot/feet. After passing the frame, with stretched and straddled legs to the handstand, which has to be performed as described in the figures **2076a-c** and held through the whole way of stretch.

L-shape hold sideways German saddle handlebar handstand

2076 j
2076 k
2076 l

From the L-shape sideways, which has to be performed for at least 2 metres, going directly to handstand with stretched, closed legs over the frame without touching the frame or else with foot/feet. After passing the frame with stretched, closed legs to the handstand, which has to be performed as described in the figures **2076a-c** and held through the whole way of stretch.

Handlebar handstand

Separate performed handstand with both hands on handlebar-grips. Arms stretched, legs closed and **vertically** stretched **straight upwards**.

2077 a
2077 b
2077 c

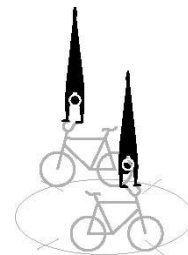

L-shape hold handlebar handstand (T)

2077 d
2077 e
2077 f

From L-shape hold or L-shape hold rev, which have to be performed for at least 2 metres, going directly to handstand without touching the handlebar and/or frame with foot/feet. The handstand must be performed as described in figures 2077a-c and held through the whole way of stretch.

The tactical enlargement is possible for the kind of execution as Swiss handlebar handstand, which has to be performed like the figures 2077g-i. The tactical enlargement is possible for the kind of execution as German handlebar handstand, which has to be performed like the figures 2077j-l.

L-shape hold Swiss handlebar handstand

2077 g
2077 h
2077 i

From L-shape hold or L-shape hold rev, which has to be performed for at least 2 metres, going directly to handstand with stretched legs over the handlebar without touching the handlebar and/or frame with foot/feet. After passing the handlebar, with stretched and straddled legs to the handstand, which has to be performed as described in the figures 2077a-c and held through the whole way of stretch.

L-shape hold German handlebar

2077 j
2077 k
2077 l

From the L-shape hold or L-shape hold rev, which has to be performed for at least 2 metres, going directly to handstand with stretched, closed legs over the handlebar without touching the handlebar or else with foot/feet. After passing the handlebar with stretched, closed legs to the handstand, which has to be performed as described in the figures 2077a-c and held through the whole way of stretch.

Maute jump

2081

Jump from saddlestand separate to fronthandlebarstand which has to be performed, after the jump, for at least 2 metres. The jumps have to be performed simultaneously. It is only allowed to perform the jumps riding opposite to each other during execution of a circle or after a counter eight. Riders do not have to touch before and after the jump.

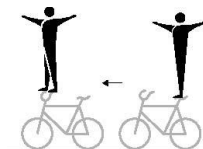

Stillstand on pedals, Stillstand pedal front wheel

2091

a-b: Standing with both feet, only, on ~~each~~ **a the** pedals. Back directed to the saddle. The stillstand has to be performed for at least 3 seconds.

c-d: Standing with one foot, only, on a pedal, the other foot on front wheel tyre. Back directed to the saddle. The stillstand has to be performed for at least 3 seconds.



(text modified on 01.01.12; 01.01.16; 01.01.17)

8.7.002 Raiser figures on two bicycles

Raiser reg. seat

Regular raiser with seat on saddle, chest directed to handlebar, both feet on ~~each a the~~ pedals.



2131
2132
2133
2134

Raiser reg. seat rev.

Reversed regular raiser with seat on saddle, back directed to handlebar, both feet on ~~each a the~~ pedals.



2135
2136
2137
2138

Raiser lady seat

Raiser with seat on saddle, chest directed to handlebar, one foot on pedal. The free leg must be stretched over the top tube to the opposite side of the bicycle, below the handlebar without the foot wedging the front wheel.



2147

Raiser stand on pins

Raiser standing with left foot on left rear-pin and with right foot on right pedal (or counterwise). Chest directed to handlebar.



2151
2152
2154

Raiser handlebarseat

Raiser, ~~with~~ seat ~~in on~~ the lower part of the handlebar (~~front wheel with crossed position~~), chest facing towards the front wheel. Both feet on ~~each a the~~ pedals. ~~Chest directed to the front wheel.~~



2161
2162
2163
2164

Raiser handlebarseat rev.

Reversed raiser, ~~with~~ seat ~~in on~~ the lower part of the handlebar (~~front wheel with crossed position~~), back directed to the front wheel. Both feet on ~~each a the~~ pedals.



2165
2166
2167
2168

Raiser head tube

Raiser sitting on the head tube, both feet on ~~each a the~~ pedals. Front wheel in front of oneself.



2176
2177
2178
2179

Raiser head tube rev.

Reversed raiser sitting on the head tube, both feet on ~~each a the~~ pedals. Front wheel behind oneself.



2180
2181
2182
2183

Standraiser

Raiser. Saddle pointing downwards, holding front wheel ~~with one hand~~ in front of oneself. Standing with both feet on ~~each a the~~ pedals.



2191
2192
2193
2194

<p>Standraiser rev. Reversed raiser. Saddle pointed downwards, holding front wheel with one hand behind oneself. Standing with both feet on each a the pedals.</p> <p><i>(text modified on 01.01.17)</i></p> <p>8.7.003 Turns on the spot on two bicycles</p> <p>Turns on the spot (T) The tactical enlargement of the turns on the spot is possible from 2 turns up to 4 turns.</p> <p>Execution according 8.2.022 turn on spot.</p> <p><i>(text modified on 01.01.16)</i></p> <p>8.7.004 Passages on two bicycles</p> <p>Passages Execution according 8.2.039 passages.</p> <p>8.7.005 Final figures on two bicycles</p> <p>Handlebarstand rev. somersault bw. hooked legs From position handlebarstand reverse somersault-jump backwards with hooked legs to standing with the feet on the floor, in front of bicycle. Both somersault have to be performed simultaneously. It is only allowed to perform the somersault riding opposite to each other during execution of a circle or after a counter eight. Riders do not have to touch before and after the somersault.</p> <p><i>(text modified on 01.01.16)</i></p> <p>8.7.006 Figures on one bicycle</p> <p>Reg. seat / Stand on pins, Saddlestand a-b: Regular seat on saddle, one foot on each pedal. Chest directed to handlebar / Stand with both feet on each a rear-pin. Both knees behind the saddle. c-d: Like a-b until slash / Standing with feet on saddle.</p> <p>Reg. seat / Shoulderseat Regular seat on saddle, one foot on each pedal. Chest directed to handlebar / Sitting on the partner's shoulders.</p>	<p>2195 2196 2197 2198</p> <p>2211 2212 2213 2214 2215 2216</p> <p>2236 2237 2238 2239 2240 2241 2242 2243</p> <p>2250 a</p> <p>2261 2266 2267</p>
---	--



Reg. seat / Shoulderstand

Regular seat on saddle, one foot on each pedal. Chest directed to handlebar / Standing with feet on the partner's shoulders.



2268
2269

Reg. seat / Chest suspended hang

Regular seat on saddle, one foot on each pedal. Chest directed to handlebar / Hanging with chest-grip on the partner's back, head downwards, upwards stretched legs in straight line with the body.



2270
2271

Reg. seat / Handlebarstand

Regular seat on saddle, one foot on each pedal. Chest directed to the handlebar / Standing with feet on handlebar-grips.



2276

Reg. seat / Handlebar handstand

Regular seat on saddle, both feet each on pedal. Chest directed to the handlebar / Handstand on handlebar-grips, arms stretched, legs closed and **vertically** stretched **straight upwards**.



2277

Reg. seat rev. / Shoulderseat

Reversed regular seat on saddle, one foot on each pedal. Back directed to the handlebar / Sitting on the partner's shoulders.



2281
2282

Reg. seat rev. / Shoulderstand

Reversed regular seat on saddle one foot on each pedal. Back directed to the handlebar / Standing with feet on the partner's shoulders.



2283

Reg. seat rev. / Chest suspended hang

Reversed regular seat on saddle, one foot on each pedal. Back directed to the handlebar / Hanging with chest-grip on the partner's back, head downwards, upwards stretched legs in straight line with the body.



2285
2286

Handlebarseat / Stand on pins, Saddlestand

a-d: Seat on handlebar, back directed to saddle, free leg stretched forward horizontally. Other foot hooked to down tube. / Standing with feet each on a rear-pin. Both knees behind the saddle.

e-h: Like **a-d** until slash / Standing with feet on the saddle.



2296

Handlebarseat rev. / Stand on pins

Reversed seat on handlebar, one foot on each pedal. Chest directed to saddle / Standing with feet each on a rear-pin. Both knees behind the saddle.



2301

Handlebarseat rev. / Saddle- handlebarstand, Saddlestand

a-d: Reversed seat on handlebar, one foot on each pedal. Chest directed to saddle / Standing with one foot on saddle, other foot on the handlebar.

e-h: Like **a-d** until slash / Standing with feet on saddle.



2302

Handlebarseat rev. / Shoulderseat

Reversed seat on handlebar, one foot on each pedal. Chest directed to saddle / Sitting on the partner's shoulders.



2303

Handlebarseat rev. / Shoulderstand

Reversed seat on handlebar, one foot on each pedal. Chest directed to saddle / Standing with feet on the partner's shoulders.



2304

Handlebarseat rev. / Chest suspended hang

Reversed seat on handlebar, one foot on each pedal. Chest directed to saddle / Hanging with chest-grip on the partner's back, head downwards, upwards stretched legs in straight line with the body.



2305

Handlebarseat rev. / Headstand

Reversed seat on handlebar, one foot on each pedal. Chest directed to saddle / Headstand on the saddle, hands on handlebar. Both legs closed and **vertically stretched straight upwards**.



2306

Frontstand / Stand on pins, Saddlestand

a-d: Stand in front of the handlebar, back directed to saddle. One foot on front-pin, other foot hooked to down tube. / Standing with each foot on a rear-pin. Both knees behind the saddle.

e-h: Like **a-d** until slash / Standing with feet on the saddle.



2311

Split / Shoulderseat

Left foot standing on left rear-pin, right foot standing on right front-pin (or counterclockwise). Chest directed to handlebar. The handlebar may not be touched with the leg / Sitting on the partner's shoulders.



2316

Sidestand / Sidestand, Ring grip

Stand with one foot on left rear-pin and the other foot on left front-pin (or counterwise). Chest directed to handlebar. The handlebar may not be touched with the leg / Similar stand on the opposite side of the bike. Partners are connected by hand-in-hand grip-connection to a ring, with stretched arms.



2317

Stand bent on saddle / Stand bent on handlebar

Stand with foot on saddle, trunk bent forward to handlebar, free leg stretched to the back in straight line with the trunk / Stand with foot on the handlebar, trunk bent forward to saddle, free leg stretched in straight line with the trunk in moving direction.



2319

Frameseat / Stand bent on saddle

Pushing one foot through the frame and placing the foot on front-pin. Free leg stretched forward, while sitting on the down tube / Stand with foot on saddle, trunk bent forward to handlebar, free leg stretched to the back in straight line with the trunk.



2321

Frameseat / Saddle handlebarstand, Saddlestand

a-b: Pushing one foot through the frame and placing the foot on front-pin. Free leg stretched forward, while sitting on the down tube / Standing with one foot on saddle, other foot on the handlebar.

c-d: Like **a-b** until slash / Standing with feet on the saddle.



2322

Frameseat / Saddle support scale

Pushing one foot through the frame and placing the foot on the front-pin. Free leg stretched forward, while sitting on the down tube / One hand on saddle, elbow supporting the body, other hand on the handlebar (handlebar-grip may be used as support for the fore-arm). Head directed in moving-direction, closed legs stretched horizontally to the back. The upper part of the body and legs have to build a straight line.



2323

Fronthang / Stand bent on saddle

Both hands leaning, behind the back, on the handlebar, frontwheel between the legs. One foot on each pedal / Stand with foot on saddle, trunk bent forward to handlebar, free leg stretched to the back in straight line with the trunk.



2331

Fronthang / Saddle handlebarstand, Saddlestand

a-b: Both hands leaning, behind the back, on the handlebar, frontwheel between the legs. One foot on each pedal / Standing with one foot on saddle, other foot on the handlebar.

c-d: Like **a-b** until slash / Standing with feet on the saddle.



2332

Fronthang / Headstand, Saddle handlebar handstand

a-b: Both hands leaning, behind the back, on the handlebar, frontwheel between the legs. One foot on each pedal / Headstand on the saddle, hands on handlebar. Both legs closed and **vertically** stretched **straight upwards**.

c-d: Like **a-b** until slash / Handstand with one hand on handlebar and other hand on saddle. Arms stretched, legs closed and **vertically** stretched **straight upwards**. The forearm or the wrist may not be leaned against the handlebar-grip.



2334

Backhang / Stand on pins

In front of the headtube hanging on the handlebar. Chest directed to the saddle, frame between the legs, both feet on **each-a the** pedals / Standing with each foot on a rear-pin. Both knees behind the saddle.



2341

Backhang / Saddle handlebarstand, Saddlestand

a-b: In front of the headtube hanging on the handlebar. Chest directed to the saddle, frame between the legs, one foot on each pedal / Standing with one foot on saddle, other foot on the handlebar.

c-d: Like **a-b** until slash / Standing with feet on the saddle.



2342

Backhang / Handlebarstand

In front of the headtube hanging on the handlebar. Chest directed to the saddle, frame between the legs, one foot on each pedal / Standing with feet on handlebar-grips.



2343

Backhang / Headstand, Saddle handlebar handstand

a-b: In front of the headtube hanging on the handlebar. Chest directed to the saddle, frame between the legs, one foot on each pedal / Headstand on the saddle, hands on handlebar. Both legs closed and **vertically** stretched **straight upwards**.

c-d: Like **a-b** until slash / Handstand with one hand on handlebar and other hand on saddle. Arms stretched, legs closed and **vertically** stretched **straight upwards**. The forearm or the wrist may not be leaned against the handlebar-grip.



2346

Lying on handlebar/ Stand bent on saddle, Saddle-stand

a-b: Lying with front of body on the handlebar, head directed to the saddle. Closed legs stretched horizontally in moving direction / Stand with foot on saddle, trunk bent forward to handlebar, free leg stretched to the back in straight line with the trunk.

c-d: Like **a-b** until slash / Standing with feet on the saddle.



2351

Lying on saddle / Handlebarstand, Handlebar-handstand

a-b: Lying with front of body on the saddle, closed stretched legs to the back / Standing with feet on handlebar-grips.

c-d: Like **a-b** until slash / Handstand on handlebar-grips, arms stretched, legs closed and **vertically stretched straight upwards**.



2352

Waterscale / Stand bent on saddle, Saddlestand

a-b: Lying with back of body in a straight line on handlebar, stretched legs or feet under the saddle / Stand with feet on the saddle, trunk bent forward to handlebar, free leg stretched to the back in straight line with the trunk.

c-d: Like **a-b**: until slash / Standing with feet on the saddle.



2353

Saddle handlebarstand / Saddle handlebarstand

Standing with one foot on the saddle, other foot on the handlebar.



2356

Saddle handlebarstand / Stand on pins, Saddlestand, Handlebarstand

a-b: Standing with one foot on the saddle, other foot on the handlebar / Standing with each foot on a rear-pin. Both knees behind the saddle.

c-d: Like **a-b** until slash / Standing with feet on the saddle.

e-f: Like **a-b**: until slash / Standing with feet on handlebar-grips.



2357

Handlebarstand / Stand on pins

Standing with feet on handlebar-grips / Standing with feet each on a rear-pin. Both knees behind the saddle.



2358 a
2358 b

Handlebarstand-turn (T) - multiple / Stand on pins

From one turn of the tactical enlargement of the fronthandlebarstand turn(s) is possible up to four half turns in maximum.

c-f: From fronthandlebarstand with half or multiple front wheel turn to fronthandlebarstand or handlebarstand reverse. After the last turn, the end position must be held for at least 2 metres / Standing with each foot on a rear-pin. Both knees behind the saddle.

g-h: The rider jumps from regular seat to fronthandlebarstand; further according figures **a-b**.

i-l: The rider jumps from regular seat to fronthandlebarstand; further according figures **c-f**.

2358 c
2358 d
2358 e
2358 f
2358 g
2358 h
2358 i
2358 j
2358 k
2358 l

Handlebarstand / Saddlestand

a-b: Standing with feet on handlebar-grips / Standing with feet on the saddle. Riders are connected by hand-in-hand grip-connection to a ring, with stretched arms.

c-f: Like **a-b** but without grip-connection.



2359

Handlebar L-shape hold / Stand on pins, Saddlestand, Saddle support straddle

a-b: Arms stretched, hands on handlebar-grips. Legs closed and horizontally stretched in moving direction. Back directed to the saddle / Standing with both feet each on a rear-pin. Both knees behind the saddle.

c-d: Like **a-b** until slash / Standing with both feet on the saddle.

e-f: Like **a-b** until slash / Arms stretched, hands on saddle. Legs horizontally straddled and stretched without touching the rider or the handlebar.



2366 a
2366 b
2366 c
2366 d
2366 e
2366 f

Handlebar support straddle / Saddle support straddle

Arms stretched, hands on handlebar-grips. Legs horizontally stretched, straddled on the outside of the arms / Arms stretched, hands on saddle. Legs horizontally stretched, straddled on the outside of the arms and stretched, without touching the partner or the handlebar.



2366 g
2366 h

Headstand / Handlebarstand

Headstand on the saddle, hands on handlebar. Both legs closed and vertically stretched straight upwards / Standing with feet on handlebar-grips.



2371

Headstand / Frame shoulderstand

Headstand on the saddle, hands on handlebar. Both legs closed and vertically stretched straight upwards / Shoulderstand with one shoulder on saddle or top tube, both hands on the handlebar. Legs closed and vertically stretched straight upwards.



2372

Headstand / Handlebar support straddle

Headstand on the saddle, hands on handlebar. Both legs closed and vertically stretched straight upwards / Arms stretched, hands on handlebar-grips. Legs horizontally stretched, straddled on the outside of the arms.

2373

Headstand / Handlebar handstand

Headstand on the saddle, hands on handlebar. Both legs closed and vertically stretched straight upwards / Handstand on handlebar-grips, arms stretched, legs closed and vertically stretched straight upwards.



2374 a
2374 b
2374 c
2374 d

Headstand / Handlebar support straddle, Handlebar handstand

Headstand on the saddle, hands on handlebar. Both legs closed and **vertically** stretched **straight upwards** / From L-shape hold, which has to be performed for at least 2 metres (partner in headstand), going directly to handstand with stretched and straddled legs without touching the handlebar and/or frame with foot/feet. The handstand must be performed as described in the figures **2374a-d** and held through the whole way of stretch.

2374 e
2374 f
2374 g
2374 h

Saddle handlebar handstand / Handlebarstand

Handstand with one hand on handlebar and other hand on saddle. Arms stretched, legs closed and **vertically** stretched **straight upwards**. The fore-arm or the wrist may not be leaned against the handlebar-grip / Standing with feet on handlebar-grips.



2376 a
2376 b

Handlebar handstand / Saddlestand

Handstand on handlebar-grips, arms stretched, legs closed and **vertically** stretched **straight upwards** / Standing with feet on the saddle.



2376 c
2376 d

Handlebar handstand / Saddle handlebar handstand

Handstand on handlebar-grips, arms stretched, legs closed and **vertically** stretched **straight upwards** / Handstand with one hand on handlebar and other hand on saddle. Arms stretched, legs closed and **vertically** stretched **straight upwards**. The fore-arm or the wrist may not be leaned against the handlebar-grip.

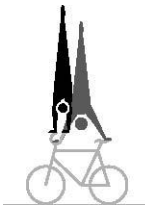

2377

Stillstand on pedals / Shoulderseat, Shoulderstand

a-b: Standing with feet, only, on **each-a the** pedals. Back directed to the saddle. The stillstand has to be performed for at least 3 seconds / Sitting on the partner's shoulders.
c-d: Like **a-b** until slash / Standing with feet on the partner's shoulders.



2391

(text modified on 01.01.16; 01.01.17)

8.7.007 Raiser figures on one bicycle

Raiser reg. seat / Stand on pins

Regular raiser with seat on saddle, chest directed to handlebar, one foot on each pedal / Standing with one foot on a rear-pin, or one foot each on a rear-pin.



2411

Raiser reg. seat / Shoulderseat

Regular raiser with seat on saddle, chest directed to handlebar, both feet on **each-a the** pedals / Sitting on the partner's shoulders.



2412
2413

Raiser reg. seat / Chest suspended hang

Regular raiser with seat on saddle, chest directed to handlebar, feet on ~~each-a the~~ pedals / Hanging with chest-grip on the partner's back, head downwards, upwards stretched legs in straight line with the body.



2414
2415

Raiser reg. seat / Shoulderstand

Regular raiser with seat on saddle, chest directed to handlebar, feet on ~~each-a the~~ pedals / Standing with feet on the partner's shoulders.



2416
2417

Raiser reg. seat rev. / Shoulderseat

Reversed regular raiser with seat on saddle, back directed to handlebar, one foot on each pedal / Sitting on the partner's shoulders.



2418
2419

Raiser reg. seat rev. / Chest suspended hang

Reversed regular raiser with seat on saddle, back directed to handlebar, one foot on each pedal / Hanging with chest-grip on the partner's back, head downwards, upwards stretched legs in straight line with the body.



2420
2421

Raiser reg. seat rev. / Shoulderstand

Reversed regular raiser with seat on saddle, back directed to handlebar, one foot on each pedal / Standing with feet on the partner's shoulders.



2422

Raiser handlebarseat / Shoulderseat

Raiser, ~~with~~ seat ~~in on~~ the lower part of the handlebar (~~front wheel with crossed position~~), chest facing towards the front wheel. Both feet on ~~each-a the~~ pedals. ~~Chest directed to the front wheel~~ / Sitting on the partner's shoulders.



2426
2427

Raiser handlebarseat / Shoulderstand

Raiser, ~~with~~ seat ~~in on~~ the lower part of the handlebar (~~front wheel with crossed position~~), chest facing towards the front wheel. Both feet on ~~each-a the~~ pedals. ~~Chest directed to the front wheel~~ / Standing with feet on the partner's shoulders.



2428
2429

Raiser head tube / Shoulderseat

Raiser sitting on the head tube, one foot on each pedal. Front wheel in front of oneself / Sitting on the partner's shoulders.



2436
2437

Raiser head tube / Shoulderstand

Raiser sitting on the head tube, one foot on each pedal. Front wheel in front of oneself / Standing with feet on the partner's shoulders.



2438
2439

Raiser head tube rev. / Shoulderseat

Reversed raiser ~~sitting on the head tube, with seat on the lower part of the handlebar (front wheel with crossed position), one~~ both feet ~~feet~~ on ~~each a~~ the pedals. Front wheel behind oneself ~~Back directed to the front wheel~~ / Sitting on the partner's shoulders.



2446
2447

Raiser head tube rev. / Shoulderstand

Reversed raiser ~~sitting on the head tube, with seat on the lower part of the handlebar (front wheel with crossed position), one~~ both feet ~~feet~~ on ~~each a~~ the pedals. Front wheel behind oneself ~~Back directed to the front wheel~~ / Standing with feet on the partner's shoulders.



2448
2449

(text modified on 01.01.16; 01.01.17)

8.7.008 Passages on one bicycle

Passages

Execution according **8.2.039** "Passages".

2471
2472
2473

Chapter VIII TABLE OF FIGURES ARTISTIC CYCLING TEAM 4

8.8.001 Artistic Cycling Team 4

The values after "T" can be reached by tactical extension of the belonging figure.

Figure No. / Name of figure	Point value
4001 a 4 f.e.o. HC.	0,3
4001 b 4 f.e.o. C.	0,5
4001 c 4 f.e.o. HC. 4 s.r.l.	0,9
4001 d 4 f.e.o. C. 4 s.r.l.	1,1
4001 e 4 f.e.o. HC. 4 s.r.r.	0,8
4001 f 4 f.e.o. C. 4 s.r.r.	1,0
4001 g 4 f.e.o. HC. 2 s.r.l. 2 s.r.r.	0,9
4001 h 4 f.e.o. C. 2 s.r.l. 2 s.r.r.	1,1
4001 i 4 f.e.o. 4 count. s.r. overlapping	2,8
4002 a 4 f.e.o. HC. bw.	1,8
4002 b 4 f.e.o. C. bw.	2,0
4002 c 4 f.e.o. HC. 4 s.r.l. bw.	3,0
4002 d 4 f.e.o. C. 4 s.r.l. bw.	3,2
4002 e 4 f.e.o. 4 count. s.r. overlapping bw.	5,2
4003 a 4 f.e.o. HC. raiser	2,3
4003 b 4 f.e.o. C. raiser	2,6
4003 c 4 f.e.o. HC. raiser frh.	2,6
4003 d 4 f.e.o. C. raiser frh.	2,9
4003 e 4 f.e.o. HC. 4 s.r.l. raiser	3,8
4003 f 4 f.e.o. C. 4 s.r.l. raiser	4,1
4003 g 4 f.e.o. HC. 4 s.r.l. raiser frh.	4,1
4003 h 4 f.e.o. C. 4 s.r.l. raiser frh.	4,4
4004 a 4 f.e.o. HC. raiser bw. frh.	5,0
4004 b 4 f.e.o. C. raiser bw.frh.	5,8
4004 c 4 f.e.o. HC. 4 s.r.l. raiser bw.frh.	6,6
4004 d 4 f.e.o. C. 4 s.r.l. raiser bw. frh.	7,2
4004 e 4 f.e.o. HC. 2 s.r.l. 2 s.r.r. raiser bw. frh.	7,7
4004 f 4 f.e.o. HC. 4 s.r.l. 4 s.r.r. raiser bw. frh.	10,7
4004 g 4 f.e.o. count. s.r. overlapping raiser bw. frh.	10,2
4006 a 4 f.e.o. diagonal pull	0,9
4006 b 4 f.e.o. diagonal pull 2 s.r.l. 2 s.r.r.	1,5
4007 a 4 f.e.o. S	1,7
4007 b 4 f.e.o. 8	2,1
4007 c 4 f.e.o. 8 through	2,5
4008 a 4 f.e.o. S bw.	4,0
4008 b 4 f.e.o. 8 bw.	4,6
4008 c 4 f.e.o. 8 through bw.	5,2
4010 a 4 f.e.o. S raiser bw. frh.	9,2
4010 b 4 f.e.o. 8 raiser bw. frh.	9,9
4010 c 4 f.e.o. 8 through raiser bw. frh.	9,6

UCI CYCLING REGULATIONS

Figure No. / Name of figure	Point value
4011 a 4 f.e.o. longline	0,9
4011 b 4 f.e.o. longline 2 s.r.l. 2 s.r.r.	1,5
4012 a 2 f.e.o. longline opp. dir.	0,9
4012 b 2 f.e.o. longline opp. dir. two mills	1,5
4013 a 2 n.e.o. longline opp. dir.	0,9
4013 b 2 n.e.o. longline opp. dir. 4 s.r.l.	1,4
4013 c 2 n.e.o. longline opp. dir. through	1,0
4013 d 2 n.e.o. longline opp. dir. trough 4 s.r.l.	1,6
4013 e 2 n.e.o. longline opp. dir. through two mills	1,8
4014 a 2 f.e.o. diagonal pull opp. dir.	0,9
4014 b 2 f.e.o. diagonal pull opp. dir. two mills	1,5
4017 a 4 n.e.o. shortline	0,8
4017 b 4 n.e.o. shortline 4 s.r.l.	1,6
4018 a 4 n.e.o. shortline bw.	2,0
4018 b 4 n.e.o. shortline 4 s.r.l. bw.	3,5
4019 a 4 n.e.o. shortline raiser	2,4
4019 b 4 n.e.o. shortline raiser frh.	2,7
4019 c 4 n.e.o. shortline 4 s.r.l. raiser	4,2
4024 a 2 con. wingmill HS 3 spin. raiser bw. frh.	10,4
4024 b 2 con. wingmill 3 spin. raiser bw. frh.	10,8
4024 c Remmlinger spin. raiser bw. frh.	13,8
4026 a 2 f.e.o. half double circle	0,5
4026 b 2 f.e.o. double circle	0,7
4026 c 2 f.e.o. half double circle 4 s.r.l.	1,1
4026 d 2 f.e.o. double circle 4 s.r.l.	1,3
4027 a 2 f.e.o. half double circle bw.	1,6
4027 b 2 f.e.o. double circle bw.	1,9
4027 c 2 f.e.o. half double circle 4 s.r.l. bw.	2,7
4027 d 2 f.e.o. double circle 4 s.r.l. bw.	2,9
4028 a 2 f.e.o. half double circle raiser	2,2
4028 b 2 f.e.o. double circle raiser	2,5
4028 c 2 f.e.o. half double circle raiser frh.	2,7
4028 d 2 f.e.o. double circle raiser frh.	3,0
4028 e 2 f.e.o. half double circle 4 s.r.l. raiser	3,6
4028 f 2 f.e.o. double circle 4 s.r.l. raiser	3,9
4028 g 2 f.e.o. half double circle 4 s.r.l. raiser frh.	4,0
4028 h 2 f.e.o. double circle 4 s.r.l. raiser frh.	4,3
4029 a 2 f.e.o. half double circle raiser bw. frh.	4,9
4029 b 2 f.e.o. double circle raiser bw. frh.	5,5
4029 c 2 f.e.o. half double circle 4 s.r.l. raiser bw. frh.	7,1
4029 d 2 f.e.o. double circle 4 s.r.l. raiser bw. frh.	7,5

UCI CYCLING REGULATIONS

Figure No. / Name of figure	Point value
4031 a 2 f.e.o. shortline	0,9
4031 b 2 f.e.o. shortline 4 s.r.l.	1,4
4032 a 2 f.e.o. shortline bw.	2,8
4032 b 2 f.e.o. shortline 4 s.r.l. bw.	3,6
4044 a 2 n.e.o. shortline opp. dir.	0,9
4044 b 2 n.e.o. shortline opp. dir. 4 s.r.l.	1,4
4044 c 2 n.e.o. shortline opp. dir. through	1,0
4044 d 2 n.e.o. shortline opp. dir. through 4 s.r.l.	1,6
4044 e 2 n.e.o. half shortline opp. dir. count. s.r.	1,3
4044 f 2 n.e.o. shortline opp. dir. count. s.r	1,7
4045 a 2 n.e.o. shortline opp. dir. bw.	2,2
4045 b 2 n.e.o. shortline opp. dir. through bw.	2,4
4045 c 2 n.e.o. half shortline opp. dir. count. s.r.bw.	3,0
4045 d 2 n.e.o. shortline opp. dir. count. s.r. bw.	3,5
4047 a 2 n.e.o. shortline opp. dir. raiser	2,7
4047 b 2 n.e.o. shortline opp. dir. raiser frh.	3,2
4047 c 2 n.e.o. shortline opp. dir. through raiser	2,8
4047 d 2 n.e.o. shortline opp. dir. through raiser frh.	3,3
4047 e 2 n.e.o. half shortline opp. dir. count. s.r. raiser bw. frh.	9,4
4047 f 2 n.e.o. shortline opp. dir. count. s.r. raiser bw. frh.	10,5
4047 g 2 n.e.o. shortline opp. dir. count. s.r. through raiser bw. frh.	11,8
4071 a 2 con. HC.	0,9
4071 b 2 con. C.	1,1
4071 c 2 con. HC. 2 con. s.r.l.	1,4
4071 d 2 con. C. 2 con. s.r.l.	1,6
4071 e 2 con. HC. 4 s.r.l.	1,8
4071 f 2 con. C. 4 s.r.l.	2,0
4072 a 2 con. HC. bw.	1,2
4072 b 2 con. C. bw.	1,4
4072 c 2 con. HC. 2 con. s.r.l. bw.	1,9
4072 d 2 con. C. 2 con. s.r.l. bw.	2,1
4072 e 2 con. HC. 4 s.r.l. bw.	3,1
4072 f 2 con. C. 4 s.r.l. bw.	3,3
4073 a 2 con. HC. raiser	1,6
4073 b 2 con. C. raiser	1,8
4073 c 2 con. HC. raiser frh.	1,8
4073 d 2 con. C. raiser frh.	2,1
4073 e 2 con. HC. 2 con. s.r.l. raiser	2,5
4073 f 2 con. C. 2 con. s.r.l. raiser	2,8
4073 g 2 con. HC. 2 con. s.r.l. raiser frh.	2,6
4073 h 2 con. C. 2 con. s.r.l. raiser frh.	3,0
4073 i 2 con. HC. 4 s.r.l. raiser	4,1
4073 j 2 con. C. 4 s.r.l. raiser	4,4
4073 k 2 con. HC. 4 s.r.l. raiser frh.	4,4
4073 l 2 con. C. 4 s.r.l. raiser frh.	4,7

UCI CYCLING REGULATIONS

Figure No. / Name of figure	Point value
4073 m 2 con. HC. 4 s.r.l. through raiser	4,7
4073 n 2 con. C. 4 s.r.l. through raiser	5,0
4073 o 2 con. HC. 4 s.r.l. through raiser frh.	5,0
4073 p 2 con. C. 4 s.r.l. through raiser	5,3
4074 a 2 con. HC. raiser bw. frh.	2,0
4074 b 2 con. C. raiser bw. frh.	2,5
4074 c 2 con. HC. 2 con. s.r.l. raiser bw. frh.	3,0
4074 d 2 con. C. 2 con. s.r.l. raiser bw. frh.	3,3
4074 e 2 con. HC. 4 s.r.l. raiser bw. frh.	6,4
4074 f 2 con. C. 4 s.r.l. raiser bw. frh.	6,7
4074 g 2 con. HC. 4 s.r.l. through raiser bw. frh.	7,0
4074 h 2 con. C. 4 s.r.l. through raiser bw. frh.	7,3
4082 a 2 con. f.e.o. longline raiser bw. frh.	2,6
4082 b 2 con. f.e.o. longline 2 s.r.l. 2 s.r.r. raiser bw. frh.	8,3
4082 c 2 con. Longline opp. dir. 4 s.r.r. through raiser bw. frh.	10,6
4086 a 2 con. shortline	0,8
4086 b 2 con. shortline 2 con. s.r.l.	1,3
4086 c 2 con. shortline 2 con. s.r.r.	1,5
4086 d 2 con. shortline 4 s.r.l.	1,9
4087 a 2 con. shortline bw.	1,6
4087 b 2 con. shortline 2 con. s.r.l. bw.	2,4
4087 c 2 con. shortline 4 s.r.l. bw.	3,1
4088 a 2 con. shortline raiser	1,8
4088 b 2 con. shortline raiser frh.	2,1
4088 c 2 con. shortline 2 con. s.r.l. raiser	2,7
4088 d 2 con. shortline 2 con. s.r.l. raiser frh.	2,8
4088 e 2 con. shortline 4 s.r.l. raiser	4,5
4088 f 2 con. shortline 4 s.r.l. raiser frh.	4,8
4089 a 2 con. shortline raiser bw. frh.	2,3
4089 b 2 con. shortline 2 con. s.r.l. raiser bw. frh.	3,3
4089 c 2 con. shortline 4 s.r.l. raiser bw. frh.	6,8
4096 a 2 con. half shortline count. s.r.	1,1
4096 b 2 con. shortline count. s.r.	1,7
4097 a 2 con. half shortline count. s.r. bw.	2,0
4097 b 2 con. shortline count. s.r. bw.	2,6
4098 a 2 con. half shortline count. s.r. raiser	2,8
4098 b 2 con. shortline count. s.r. raiser	3,4
4098 c 2 con. half shortline count. s.r. raiser frh.	3,0
4098 d 2 con. shortline count. s.r. raiser frh.	3,6
4099 a 2 con. half shortline count. s.r. raiser bw. frh.	3,7
4099 b 2 con. shortline count. s.r. raiser bw. frh.	4,0
4105 a 2 con. shortline opp. dir.	1,1

UCI CYCLING REGULATIONS

Figure No. / Name of figure	Point value
4105 b 2 con. shortline opp. dir. 2 con. s.r.l.	1,6
4105 c 2 con. shortline opp. dir. 4 s.r.l.	2,1
4106 a 2 con. shortline opp. dir. bw.	2,0
4106 b 2 con. shortline opp. dir. 2 con. s.r.l. bw.	2,7
4106 c 2 con. shortline opp. dir. 4 s.r.l. bw.	3,7
4107 a 2 con. shortline opp. dir. raiser	2,4
4107 b 2 con. shortline opp. dir. raiser frh.	2,5
4107 c 2 con. shortline opp. dir. 2 con. s.r.l. raiser	3,2
4107 d 2 con. shortline opp. dir. 2 con. s.r.l. raiser frh.	3,4
4107 e 2 con. shortline opp. dir. 4 s.r.l. raiser	5,0
4107 f 2 con. shortline opp. dir. 4 s.r.l. raiser frh.	5,2
4108 a 2 con. shortline opp. dir. raiser bw. frh.	2,9
4108 b 2 con. shortline opp. dir. 4 s.r.l. raiser bw. frh.	7,2
4116 a Surrounding 1 around 1	1,5
4117 a Surrounding 1 around 1 bw.	2,1
4121 a Two mills	1,2
4121 b Two mills 4 s.r.r.	1,9
4122 a Two mills bw.	1,5
4122 b Two mills bw. inside indiv.	2,6
4122 c Two mills bw. in- a. outside indiv.	2,9
4123 a Two mills raiser	2,2
4123 b Two mills raiser frh.	2,4
4123 c Two mills raiser frh. inside indiv.	3,6
4123 d Two mills raiser inside indiv. frh.	3,9
4123 e Two mills raiser frh. in- a. outside indiv.	3,8
4123 f Two mills raiser in- a. outside indiv. frh.	4,1
4124 a Two mills raiser bw. frh.	2,5
4124 b Two mills raiser bw. inside indiv. frh.	5,2
4124 c Two mills raiser bw. in- a. outside indiv. frh.	5,7
4124 d Two mills 4 s.r.r. raiser bw. in- a. outside indiv. frh.	7,2
4133 a Two insiderings raiser	2,4
4133 b Two insiderings raiser inside indiv.	3,8
4133 c Two insiderings raiser inside indiv. frh.	4,1
4133 d Two insiderings raiser in- a. outside indiv.	4,1
4133 e Two insiderings raiser in- a. outside indiv. frh.	4,4
4134 a Two insiderings raiser bw.	2,7
4134 b Two insiderings raiser bw. inside indiv. frh.	5,5
4134 c Two insiderings raiser bw. in- a. outside indiv. frh.	6,0
4134 d Two mills 3 spin. raiser bw. in- a. outside indiv. frh.	9,2
4134 e Two insiderings 3 spin. raiser bw. in- a. outside indiv. frh.	10,4
4135 a Two outsiderings raiser	2,8

UCI CYCLING REGULATIONS

Figure No. / Name of figure	Point value
4135 b Two outsiderings raiser inside indiv.	4,2
4135 c Two outsiderings raiser inside indiv. frh.	4,5
4135 d Two outsiderings raiser in- a. outside indiv.	4,5
4135 e Two outsiderings raiser in- a. outside indiv. frh.	4,8
4136 a Two outsiderings raiser bw.	3,1
4136 b Two outsiderings raiser bw. inside indiv. frh.	5,9
4136 c Two outsiderings raiser bw. in- a. outside indiv. frh.	6,4
4151 a 4 con. HC.	0,8
4151 b 4 con. C.	1,2
4151 c 4 con. HC. 2 con. s.r.l.	1,8
4151 d 4 con. C. 2 con. s.r.l.	2,0
4151 e 4 con. HC. 4 s.r.l.	2,1
4151 f 4 con. C. 4 s.r.l.	2,4
4152 a 4 con. HC. bw.	1,5
4152 b 4 con. C. rw	1,7
4152 c 4 con. HC. 2 con. s.r.l. bw.	2,4
4152 d 4 con. C. 2 con. s.r.l. bw.	2,6
4152 e 4 con. HC. 4 s.r.l. bw.	3,6
4152 f 4 con. C. 4 s.r.l. bw.	3,8
4153 a 4 con. HC. raiser	2,1
4153 b 4 con. C. raiser	2,4
4153 c 4 con. HC. raiser frh.	2,3
4153 d 4 con. C. raiser frh.	2,7
4153 e 4 con. HC. 2 con. s.r.l. raiser	3,0
4153 f 4 con. C. 2 con. s.r.l. raiser	3,3
4153 g 4 con. HC. 2 con. s.r.l. raiser frh	3,1
4153 h 4 con. C. 2 con. s.r.l. raiser frh	3,4
4153 i 4 con. HC. 4 s.r.l. raiser	4,9
4153 j 4 con. C. 4 s.r.l. raiser	5,2
4153 k 4 con. HC. 4 s.r.l. raiser frh.	5,3
4153 l 4 con. C. 4 s.r.l. raiser frh.	5,6
4154 a 4 con. HC. raiser bw. frh.	2,9
4154 b 4 con. C. raiser bw. frh.	3,2
4154 c 4 con. HC. 2 con. s.r.l. raiser bw. frh.	3,7
4154 d 4 con. C. 2 con. s.r.l. raiser bw. frh.	4,0
4154 e 4 con. HC. 4 s.r.l. raiser bw. frh.	7,4
4154 f 4 con. C. 4 s.r.l. raiser bw. frh.	7,7
4154 g 4 con. HC. 3 spin. raiser bw. frh.	10,1
4154 h 4 con. C. 3 spin. raiser bw. frh.	10,5
4161 a 4 con. shortline	1,0
4161 b 4 con. shortline 2 con. s.r.l.	1,6
4161 c 4 con. shortline 2 con. s.r.r.	1,8
4161 d 4 con. shortline 4 s.r.l.	2,1
4161 e 4 n.e.o. half shortline count. s.r.	1,0
4161 f 4 n.e.o. shortline count. s.r.	1,2
4162 a 4 con. shortline bw.	1,7

UCI CYCLING REGULATIONS

Figure No. / Name of figure	Point value
4162 b 4 con. shortline 2 con. s.r.l. bw.	2,6
4162 c 4 con. shortline 2 con. s.r.r. bw.	3,2
4162 d 4 con. shortline 4 s.r.l. bw.	3,3
4163 a 4 con. shortline raiser	2,2
4163 b 4 con. shortline raiser frh.	2,4
4163 c 4 con. shortline 2 con. s.r.l. raiser	3,3
4163 d 4 con. shortline 2 con. s.r.l. raiser frh.	3,5
4163 e 4 con. shortline 4 s.r.l. raiser	5,3
4163 f 4 con. shortline 4 s.r.l. raiser frh.	5,6
4164 a 4 con. shortline raiser bw. frh.	3,0
4164 b 4 con. shortline 2 con. s.r.l. raiser bw. frh.	3,6
4164 c 4 con. shortline 4 s.r.l. raiser bw. frh.	7,7
4164 d 4 con. shortline 2 s.r.l. 2 s.r.r. raiser bw. frh.	8,8
4164 e 4 n.e.o. half shortline count. s.r. raiser bw. frh.	9,5
4164 f 4 n.e.o. shortline count. s.r. raiser bw. frh.	11,2
4171 a Surrounding 3 con. around 1	1,7
4172 a Surrounding 3 con. around 1 bw.	2,3
4173 a Surrounding 3 con. around 1 raiser	2,9
4173 b Surrounding 3 con. around 1 raiser frh.	3,1
4174 a Surrounding 3 con. around 1 raiser bw. frh.	3,6
4181 a Coach HC.	1,3
4181 b Coach C.	1,5
4182 a Coach HC. raiser	2,7
4182 b Coach C. raiser	2,9
4183 a Snake HC.	1,3
4183 b Snake C.	1,5
4191 a Chain HC.	1,0
4191 b Chain C.	1,2
4192 a Chain HC. raiser frh.	2,8
4192 b Chain C. raiser frh.	3,2
4196 a Saddlegrip HC.	1,2
4196 b Saddlegrip C.	1,4
4197 a Saddlegrip pass through	2,4
4198 a Saddlegripring	1,8
4198 b Saddlegripring 4 s.r.r.	2,2
4199 a Saddlegripring bw.	2,5
4199 b Saddlegripring bw. inside indiv.	3,3
4199 c Saddlegripring bw. in- a. outside indiv.	3,5

UCI CYCLING REGULATIONS

Figure No. / Name of figure	Point value
4211 a 2 con. wingmill	1,2
4211 b 2 con. wingmill HS 2 con. s.r.r.	1,7
4211 c 2 con. wingmill 2 con. s.r.r.	1,9
4211 d 2 con. wingmill HS 4 s.r.r.	2,3
4211 e 2 con. wingmill 4 s.r.r.	2,5
4212 a 2 con. wingmill bw.	1,8
4212 b 2 con. wingmill HS 2 con. s.r.r. bw.	2,7
4212 c 2 con. wingmill 2 con. s.r.r. bw.	2,9
4212 d 2 con. wingmill bw. inside indiv.	3,1
4212 e 2 con. wingmill bw. in- a. outside indiv.	3,3
4213 a 2 con. wingmill raiser	2,4
4213 b 2 con. wingmill raiser frh.	2,5
4213 c 2 con. wingmill raiser frh. inside indiv.	3,7
4213 d 2 con. wingmill raiser inside indiv. frh.	3,8
4213 e 2 con. wingmill raiser frh. in- a. outside indiv.	4,1
4213 f 2 con. wingmill raiser in- a. outside indiv. frh.	4,3
4214 a 2 con. wingmill raiser bw. frh.	3,5
4214 b 2 con. wingmill raiser bw. inside indiv. frh.	5,4
4214 c 2 con. wingmill raiser bw. in- a. outside indiv. frh.	5,6
4214 d 2 con. wingmill mill with 2 s.r.r. raiser bw. frh.	6,3
4214 e 2 con. wingmill HS 2 con. s.r.r. raiser bw. frh.	5,9
4214 f 2 con. wingmill 2 con. s.r.r. raiser bw. frh.	6,2
4214 g 2 con. wingmill HS 4 s.r.r. raiser bw. frh.	7,3
4214 h 2 con. wingmill HS 4 s.r.r. raiser bw. inside indiv. frh.	7,7
4214 i 2 con. wingmill HS 4 s.r.r. raiser bw. in- a. outside indiv. frh.	8,0
4214 j 2 con. wingmill 4 s.r.r. raiser bw. frh.	7,7
4214 k 2 con. wingmill 4 s.r.r. raiser bw. inside indiv. frh.	8,0
4214 l 2 con. wingmill 4 s.r.r. raiser bw. in- a. outside indiv. frh.	8,4
4223 a 2 con. wingring raiser	2,6
4223 b 2 con. wingring raiser frh.	2,8
4223 c 2 con. wingring raiser frh. inside indiv.	3,9
4223 d 2 con. wingring raiser inside indiv. frh.	4,1
4223 e 2 con. wingring raiser frh. in- a. outside indiv.	4,3
4223 f 2 con. wingring raiser in- a. outside indiv. frh.	4,6
4224 a 2 con. wingring raiser bw. frh.	3,4
4224 b 2 con. wingring raiser bw. inside indiv. frh.	5,8
4224 c 2 con. wingring raiser bw. in- a. outside indiv. frh.	6,0
4230 a 2 con. wingmill mill with 2 f.e.o. C.	1,3
4231 a 2 con. wingmill mill with 2 f.e.o. C. bw.	2,8
4232 a 2 con. wingmill mill with 2 f.e.o. C. raiser	3,5
4232 b 2 con. wingmill mill with 2 f.e.o. C. raiser frh.	3,7
4232 c 2 con. wingring insidering with 2 f.e.o. C. raiser	3,7
4232 d 2 con. wingring insidering with 2 f.e.o. C. raiser frh.	3,9

UCI CYCLING REGULATIONS

Figure No. / Name of figure	Point value
4233 a 2 con. wingmill mill with 2 f.e.o. C. raiser bw. frh.	4,9
4233 b 2 con. wingring insidering with 2 f.e.o. C. raiser bw. frh.	5,2
4233 c 2 con. wingmill mill with 3 spin. raiser bw. frh.	8,3
4241 a Mill	1,9
4241 b Mill 4 s.r.r.	2,7
4242 a Mill bw.	2,7
4242 b Mill bw. inside indiv.	4,0
4242 c Mill bw. in- a. outside indiv.	4,2
4243 a Mill raiser	2,7
4243 b Mill raiser frh.	2,9
4243 c Mill raiser frh. inside indiv.	4,4
4243 d Mill raiser inside indiv. frh.	4,6
4243 e Mill raiser frh. in- a. outside indiv.	4,8
4243 f Mill raiser in- a. outside indiv. frh.	5,1
4244 a Mill raiser bw. frh.	3,9
4244 b Mill raiser bw. inside indiv. frh.	6,7
4244 c Mill raiser bw. in- a. outside indiv. frh.	7,3
4244 d Mill 4 s.r.r. raiser bw. frh.	10,3
4244 e Mill 4 s.r.r. raiser bw. in- a. outside indiv. frh.	11,1
4251 a Insidering around 1 raiser	3,1
4251 b Insidering around 1 raiser inside indiv.	4,7
4251 c Insidering around 1 raiser inside indiv. frh.	4,8
4251 d Insidering around 1 raiser in- a. outside indiv.	5,3
4251 e Insidering around 1 raiser in- a. outside indiv. frh.	5,4
4252 a Insidering around 1 raiser bw.	4,0
4252 b Insidering around 1 raiser bw. inside indiv. frh.	7,1
4252 c Insidering around 1 raiser bw. in- a. outside indiv. frh.	7,7
4258 a Insidering raiser	2,5
4258 b Insidering raiser inside indiv.	4,3
4258 c Insidering raiser inside indiv. frh.	4,4
4258 d Insidering raiser in- a. outside indiv.	4,8
4258 e Insidering raiser in- a. outside indiv. frh.	4,9
4259 a Insidering raiser bw.	3,6
4259 b Insidering raiser bw. inside indiv. frh.	6,1
4259 c Insidering raiser bw. in- a. outside indiv. frh.	6,5
4259 d Insidering raiser bw. turn on frh.	8,5
4259 e Insidering raiser bw. turn on a. outside indiv. frh.	8,9
4267 a Ring with opp. grips raiser	2,8
4267 b Ring with opp. grips HS / Insidering HS raiser	3,3
4267 c Ring with opp. grips raiser inside indiv.	4,6
4267 d Ring with opp. grips raiser inside indiv. frh.	4,7
4267 e Ring with opp. grips raiser in- a. outside indiv.	5,1
4267 f Ring with opp. grips raiser in- a. outside indiv. frh.	5,2

UCI CYCLING REGULATIONS

Figure No. / Name of figure	Point value
4268 a Ring with opp. grips raiser bw.	3,8
4268 b Ring with opp. grips HS / Insidering HS raiser bw.	4,3
4268 c Ring with opp. grips raiser bw. inside indiv. frh.	6,4
4268 d Ring with opp. grips raiser bw. in- a. outside indiv. frh.	6,8
4272 a Outsidering raiser	3,0
4272 b Outsidering raiser inside indiv.	4,8
4272 c Outsidering raiser inside indiv. frh.	4,9
4272 d Outsidering raiser in- a. outside indiv.	5,2
4272 e Outsidering raiser in- a. outside indiv. frh.	5,3
4272 f Outsidering HS / Insidering HS raiser	3,6
4273 a Outsidering raiser bw.	4,0
4273 b Outsidering raiser bw. inside indiv. frh.	7,2
4273 c Outsidering raiser bw. in- a. outside indiv. frh.	8,0
4273 d Outsidering HS / Insidering HS raiser bw.	4,5
4280 a Half door	1,2
4280 b Door	1,9
4280 c Half opp. dir. door	1,5
4280 d Opp. dir. door	2,2
4280 e Opp. dir. door sim.	3,3
4281 a Half door bw.	2,5
4281 b Door bw.	3,4
4281 c Half opp. dir. door bw.	2,6
4281 d Opp. dir. door bw.	3,5
4281 e Opp. dir. door sim. bw.	4,5
4281 f Opp. dir. door Count. s.r. sim. bw.	6,4
4282 a Half door raiser	2,7
4282 b Door raiser	3,2
4282 c Half door raiser frh.	3,0
4282 d Door raiser frh.	3,5
4283 a Half door raiser bw. frh.	5,0
4283 b Door raiser bw. frh.	5,7
4284 a Opp. dir. door sim. raiser bw. frh.	7,8
4284 b Mill with opp. dir. door sim. raiser bw. frh.	8,7
4285 a Half opp. dir. door raiser	3,0
4285 b Opp.dir. door raiser	3,6
4285 c Half opp. dir. door raiser frh.	3,3
4285 d Opp. dir. door raiser frh.	3,9
4286 a Half opp. dir. door raiser bw. frh.	5,3
4286 b Opp. dir. door raiser bw. frh.	6,0
4287 a Opp. dir. door sim. raiser	5,1
4287 b Opp. dir. door sim. raiser frh.	5,4
4288 a Mill with half opp. dir. door raiser bw. frh.	5,7

UCI CYCLING REGULATIONS

Figure No. / Name of figure	Point value
4288 b Mill with opp. dir. door raiser bw. frh.	6,8
4291 a Double door	1,6
4292 a Double door bw.	4,0
4292 b Snake double door bw.	5,7
4293 a Double door raiser bw. frh.	7,5
4293 b Turbine raiser double door raiser bw. frh.	9,1
4294 a Snake double door raiser bw. frh.	9,2
4294 b Turbine raiser snake double door raiser bw. frh. opp-dir.	10,5
4296 a Count. s.r. door bw.	5,3
4297 a Count. s.r. door raiser bw. frh.	9,2
4298 a Opp. dir. door count. s.r. sim. raiser bw. frh.	10,8
4298 b Mill with opp. dir. door count. s.r. sim. raiser bw. frh.	12,0
4307 a Half dooring raiser bw.	4,8
4307 b Dooring raiser bw.	6,4
4307 c Compass raiser with ring Dooring raiser bw. opp-dir.	8,0
4316 a Star inside	2,4
4316 b Star inside 4 s.r.l.	2,7
4317 a Star inside raiser	4,2
4317 b Star inside raiser inside indiv.	5,1
4317 c Star inside raiser inside indiv. frh.	5,3
4317 d Star inside raiser bw. inside indiv. frh.	9,2
4326 a Star outside	2,4
4326 b Star outside bw. inside indiv.	4,3
4326 c Star outside 4 s.r.l. bw. inside indiv.	4,5
4327 a Star opp. dir. raiser inside indiv.	4,8
4327 b Star opp. dir. raiser inside indiv. frh.	5,0
4327 c Star opp. dir. raiser bw. inside indiv. frh.	9,5
4328 a Star outside raiser	4,0
4328 b Star outside raiser bw. inside indiv. frh.	6,7
4328 c Star outside 4 s.r.l. raiser bw. inside indiv. frh.	8,2
4331 a Star inside raiser ½ turn on the spot raiser	6,2
4331 b Star inside raiser 1 turn on the spot raiser	8,0
4341 a 2 con. raiser ½ turn on the spot T (5,9 - 6,2)	5,6
4341 b 2 con. raiser 1 turn on the spot T (7,1 - 7,5)	6,8
4341 c 2 con. raiser 1½ turns on the spot T (7,8)	7,4
4341 d 2 con. raiser 2 turns on the spot	8,3
4342 a 4 con. raiser ½ turn on the spot T (6,3 - 6,6)	6,0

UCI CYCLING REGULATIONS

Figure No. / Name of figure	Point value
4342 b 4 con. raiser 1 turn on the spot T (7,7 - 8,0)	7,3
4342 c 4 con. raiser 1½ turns on the spot T (8,6)	8,2
4342 d 4 con. raiser 2 turns on the spot	9,0

		Given			
Shown		4341a	4341b	4341c	4341d
		½	1	1 ½	2
	½	5,6			
	1	5,9	6,8		
	1½	6,2	7,1	7,4	
	2		7,5	7,8	8,3

		Given			
Shown		4342a	4342b	4342c	4342d
		½	1	1 ½	2
	½	6,0			
	1	6,3	7,3		
	1½	6,6	7,7	8,2	
	2		8,0	8,6	9,0

(text modified on 01.01.16; 01.01.17)

**Chapter IX EXPLANATIONS OF FIGURES ARTISTIC CYCLING
TEAM 4**

8.9.001 Artistic Cycling Team 4

4 following each other half circle

All riders are riding with same distances between each other and at same distances to the 4-metre-circle, outside of the 4-metre-circle.

A figure ends when, the 4-metre-circle is rounded half at the outside of the 4-metre-circle.

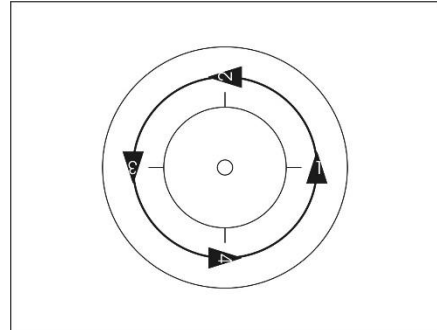

4001 a
4002 a
4003 a
4003 c
4004 a

4 following each other circle

All riders are riding with same distances between each other and at same distances to the 4-metre-circle, outside of the 4-metre-circle.

The figure ends, when the 4-metre-circle is rounded completely at the outside of the 4-metre-circle.

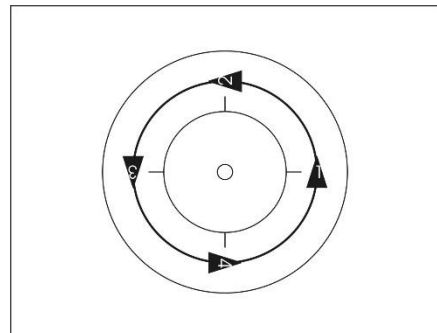

4001 b
4002 b
4003 b
4003d
4004 b

4 following each other half circle 4 single rings left

All riders are riding with same distances between each other and at same distances to the 4-metre-circle, outside of the 4-metre-circle. During the figure the riders have to perform simultaneously four same sized and uniform single ring left. The half circle has to be performed at least 2 metre before and 2 metre after the single ring left.

A figure ends when the 4-metre-circle is rounded half at the outside of the 4-metre-circle.

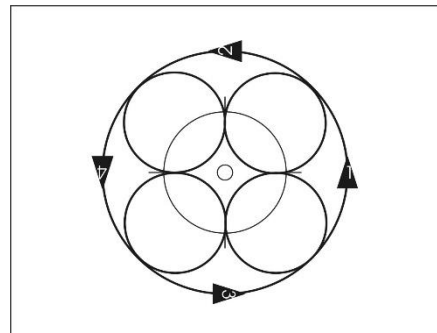

4001 c
4002 c
4003 e
4003 g
4004 c

Single ring left (8.3.029)

4 following each other circle 4 single rings left

All riders are riding with same distances between each other and at same distances to the 4-metre-circle, outside of the 4-metre-circle. During the figure the riders have to perform simultaneously four same sized, and uniform single ring left. The circle has to be performed at least 2 metre before and 2 metre after the single ring left.

The figure ends when the 4-metre-circle is rounded completely at the outside of the 4-metre-circle.

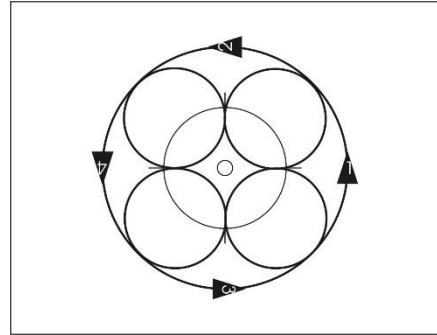

4001 d
4002 d
4003 f
4003 h
4004 d

Single ring left (8.3.029)

4 following each other half circle 4 single rings right

All riders are riding with same distances between each other and at same distances to the 4-metre-circle, outside of the 4-metre-circle. During the figure the riders have to perform simultaneously four same sized, and uniform single ring right. The half circle has to be performed at least 2 metre before and 2 metre after the single ring right.

The figure ends when the 4-metre-circle is rounded half at the outside of the 4-metre-circle.

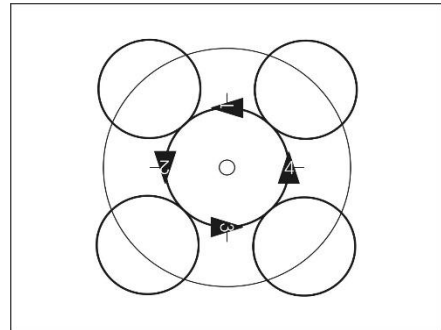

4001 e

Single ring right (8.3.030)

4 following each other circle 4 single rings right

All riders are riding with same distances between each other and at same distances to the 4-metre-circle, outside of the 4-metre-circle. During the figure the riders have to perform simultaneously four same sized, and uniform single ring right. The circle has to be performed at least 2 metre before and 2 metre after the single ring right.

The figure ends when the 4-metre-circle is rounded completely at the outside of the 4-metre-circle.

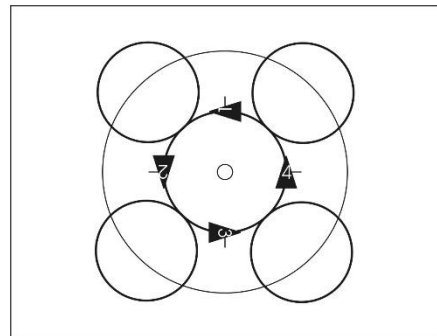

4001 f

Single ring right (8.3.030)

4 following each other half circle 2 s.r.l. 2 s.r.r.

All riders are riding with same distances between each other and at same distances to the 4-metre-circle, outside of the 4-metre-circle. During the figure the riders have to perform simultaneously two same sized and uniform single ring right and two same sized and uniform single ring left. The riders which are riding on the same axis have to perform the same type of single ring. The circle has to be performed at least 2 metre before and 2 metre after the single ring right and single ring left.

A figure ends when the 4-metre-circle is rounded half at the outside of the 4-metre-circle.

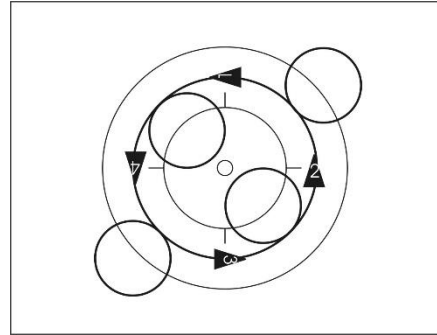

4001 g
4004 e

Single ring left (**8.3.029**)
Single ring right (**8.3.030**)

4 following each other circle 2 s.r.l. 2 s.r.r.

All riders are riding with same distances between each other and at same distances to the 4-metre-circle, outside of the 4-metre-circle. During the figure the riders have to perform simultaneously two same sized and uniform single ring right and two same sized and uniform single ring left. The riders which are riding on the same axis have to perform the same type of single ring. The circle has to be performed at least 2 metre before and 2 metre after the single ring right and single ring left.

The figure ends when the 4-metre-circle is rounded completely at the outside of the 4-metre-circle.

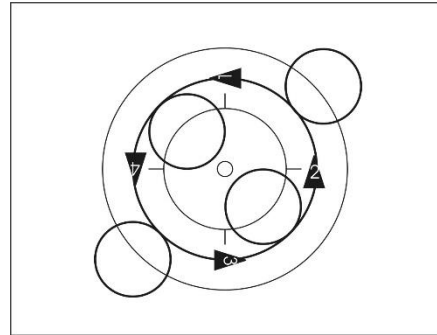

4001 h

Single ring left (**8.3.029**)
Single ring right (**8.3.030**)

4 following each other half circle 4 s.r.l. 4 s.r.r.

All riders are riding with same distances between each other and at same distances to the 4-metre-circle, outside of the 4-metre-circle. During the figure the riders have to perform simultaneously 4 single ring left and afterwards 4 single ring right same sized and uniform. The circle has to be performed at least 2 metre before the single ring left and 2 metre after the single ring right. The figure ends when the 4-metre-circle is rounded half at the outside of the 4-metre-circle.

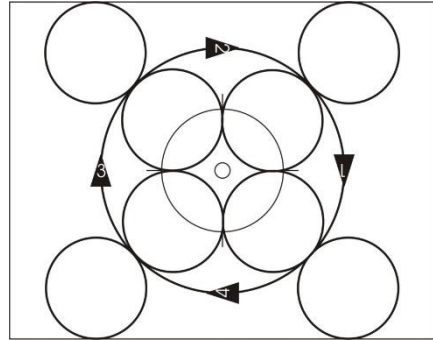

4004 f

Single ring left (8.3.029)
Single ring right (8.3.030)

4 following each other count. s.r. overlapping

All riders are riding with same distances between each other and at same distances from the 4-metre-circle, outside of the 4-metre-circle. During the figure the riders have to perform simultaneously, same sized and uniform 4 counter single rings. Each second ring has to overlap with the first ring of the rider riding ahead.

4001 i
4002 e
4004 g

Counter single ring overlapping (8.3.032)

4 following each other diagonal pull

All riders are following each other crossing the riding-area, from a corner in a straight line over the middle of the riding-area to the opposite corner. The distance between rider 1, 2, 3 and 4 may not be more than 2 metres. The way of stretch for the diagonal pull, for each rider will start at the distance of 1 metre from the starting corner until 1 metre before the opposite corner.

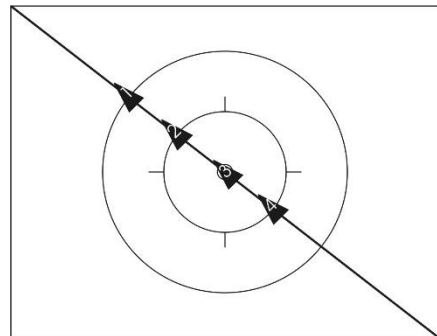

4006 a

**4 following each other diagonal pull
2 s.r.l. 2 s.r.r.**

All riders are following each other crossing the riding-area, from a corner in a straight line over the middle of the riding-area to the opposite corner.

The distance between rider 1, 2, 3 and 4 may not be more than 2 metres.

During the figure the riders have to perform 2 single rings right and 2 single rings left simultaneously. Rider 1 and 3 and rider 2 and 4 have to perform the same type of a single ring.

The 4 following each other cross line has to be performed at least 2 metres before of and 2 metres after the single rings. The way of stretch for the diagonal pull, for each rider, will start at the distance of 1 metre from the starting corner until 1 metre before the opposite corner.

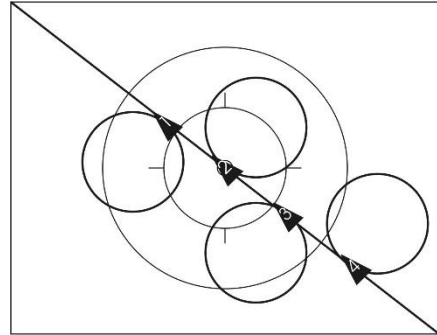

4006 b

Single ring left (8.3.029)

Single ring right (8.3.030)

4 following each other half eight

All riders following each other, on one common half eight. The distance between rider 1, 2, 3 and 4 may not be more than 2 metres and has to be identical.

Half Eight (8.3.035)

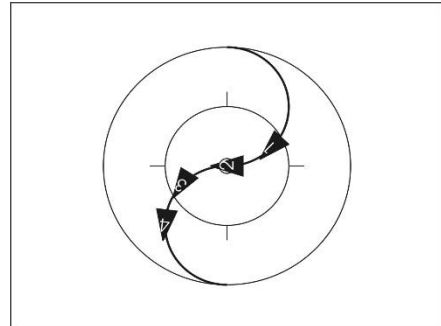

**4007 a
4008 a
4010 a**

4 following each other eight

All riders following each other, on one common half eight. The distance between rider 1, 2, 3 and 4 may not be more than 2 metres and has to be identical.

Eight (8.3.036)

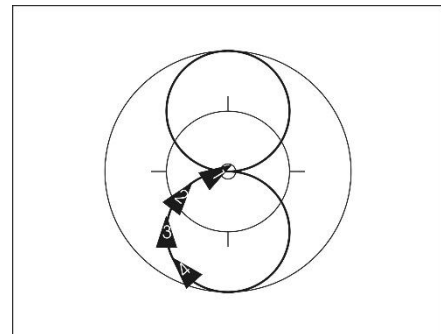

**4007 b
4008 b
4010 b**

4 following each other eight through

All riders are riding at the same distance between each other and at they have all the same distance to a spot on one half of the riding-area.

Rider 1 and 3 perform an eight without changing the distances between each other. After completing the eight they circle the spot at least once. Rider 2 and 4 circle the spot at least once.

After circling the spot they perform an eight without changing the distance between each other. The figure ends at the moment that all riders are riding at the same distances towards each other, while circling the spot. The distance of each rider to the spot must be the same.

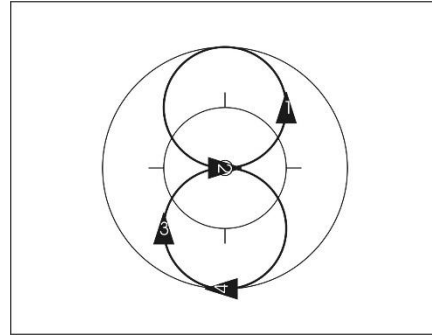

4007 c
4008 c
4010 c

Eight (8.3.036)

4 following each other longline

4011

All riders are riding at the same distance between each other on the line which runs parallel to the long side of the riding-area. The distance between rider 1 and 2 may not occur more than 2 metres and must be identical to the distance between rider 2 and 3 and between rider 3 and 4.

If in the text is mentioned, 2 single rings left 2 single rings right, during the figure 2 single rings right and 2 single rings left simultaneous from each group have to be executed with the same size and uniform. Rider 1 and 3 and rider 2 and 4 have to perform the same type of a single ring. The longline has to be performed at least 2 metres before of and 2 metres after the single rings.

Longline (8.3.042)

Single ring left (8.3.029)

Single ring right (8.3.030)

2 following each other longline opposite direction

4012

Each 2 riders are riding following each other. The distance between rider 1 and 2 must be identical to the distance between riders 3 and 4 and may not occur more than 2 metres. One group will start from the short side of the riding-area and ride to the opposite side of the riding-area. The other group will start from the other short side and will ride to the opposite side of the riding-area. Both groups are riding with the same speed during this figure.

If in the text is mentioned, two mills, during the figure two mills simultaneous from each group have to be executed. As soon as all riders are on the same level, the new groups have to connect simultaneous into a mill. The riders are connected with their left hands and are riding with same distances to each other a complete circle (360°) around a spot. The longline opposite direction has to be performed at least 2 metres before of and 2 metres after the mills.

Longline (8.3.042)

2 next to each other longline opposite direction

4013

Each 2 riders are riding next to each other without grip connection on an axis which runs parallel to the long side of the riding-area. The distance between rider 1 and 2 must be identical to the distance between riders 3 and 4. All riders are riding on an axis parallel to the long side of the riding-area. One group will start from the short side of the riding-area and ride to the opposite side of the riding-area. The other group will start from the other short side and will ride to the opposite side of the riding-area. Both groups are riding with the same speed during this figure.

If in the text is mentioned, 4 single rings left, during the figure 4 single rings left simultaneous from each group have to be executed with the same size and uniform.

If in the text is mentioned, through, after half of the way of stretch the rider is riding through the space which is built from two riders.

If in the text is mentioned, two mills, during the figure two mills simultaneous group executed. As soon as all riders are on the same level, the new groups have to connect simultaneous into a mill. The riders are connected with their left hands and are riding with same distances to each other a complete circle (360°) around a spot.

The longline opposite direction has to be performed at least 2 metres before of and 2 metres after the single rings or after the mills.

Longline (8.3.042)

Single ring left (8.3.029)

2 following each other diagonal pull opposite direction

4014

Each 2 riders are riding following each other. The distance between rider 1 and 2 must be identical to the distance between riders 3 and 4 and may not occur more than 2 metres. One group will start from one corner of the riding-area and ride to the opposite corner of the riding-area. The other group will start from the other corner and will ride to the opposite corner of the riding-area.

If in the text is mentioned, two mills, during the figure two mills simultaneous from each group have to be executed. As soon as all riders are on the same level, the new groups have to connect simultaneous into a mill. The riders are connected with their left hands and are riding with same distances to each other a complete circle (360°) around a spot. The diagonal pull opposite direction has to be performed at least 2 metres before of and 2 metres after the mills.

Diagonal pull (8.3.042)

4 next to each other shortline

All riders are riding next to each other, without grip connection, each on an own imaginary axis parallel to the short side of the riding-area and each on the same axis parallel which runs towards the long side of the riding-area. The distance between rider 1, 2, 3, and 4 must be identical. The way of stretch for the shortline will start at 1 metre distance from the long side of the riding-area until 1 metre distance before the opposite border of the riding-area.

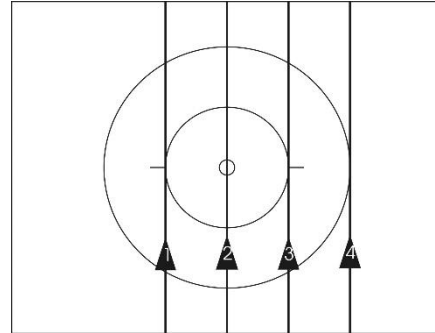

4017 a
4018 a
4019 a
4019 b

4 next to each other shortline 4 single rings left

All riders are riding next to each other, without grip connection, each on an own imaginary axis parallel to the short side of the riding-area and each on the same axis parallel which runs towards the long side of the riding-area. The distance between rider 1, 2, 3, and 4 must be identical. During the figure, each rider performs simultaneously a same sized and uniform single ring left. The shortline has to be performed 2 metres in front of and 2 metres towards the single ring left.

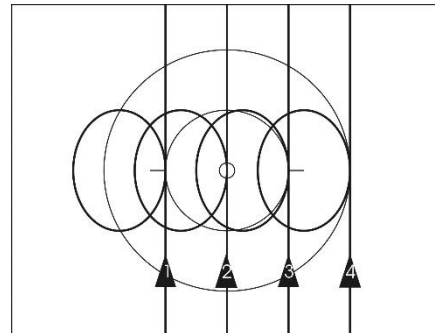

4017 b
4018 b
4019 c

The way of stretch for the shortline will start at 1 metre distance from the long side of the riding-area until 1 metre distance before the opposite border of the riding-area.

Single ring left (8.3.029)

2 connected wingmill half surrounding 3 spinnings

Two riders of each group are connected by grip connection and are riding side by side. Both groups are riding with same distances between each other on the same axis, while riding at the same distances around the centre of the riding-area. The distance between rider 1 and 2 has to be identical to the distance between riders 3 and 4. The inside riders of the groups are connected to each other by their left hands, above the centre of the riding-area.

During the figure the grip connections have to be released simultaneously and in motion. Each rider performs 3 spinnings simultaneously and on the same axis. After the spinnings the riders have to close the grip connection simultaneously and in motion. Before releasing and after closing the grip connection the wingmill has to be performed at least 2 metres.

The figure ends not before a half surrounding around the centre of the riding-area is performed.

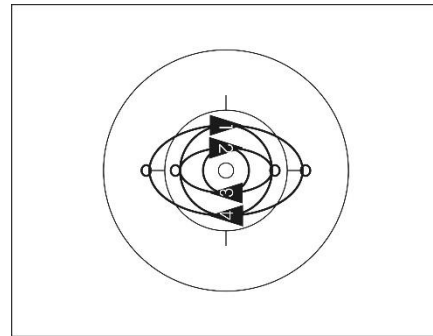

4024 a

Spinnings (8.3.037)

2 connected wingmill 3 spinnings

Two riders of each group are connected by grip connection and are riding side by side. Both groups are riding with same distances between each other on the same axis, while riding at the same distances around the centre of the riding-area. The distance between rider 1 and 2 has to be identical to the distance between riders 3 and 4. The inside riders of the groups are connected to each other by their left hands, above the centre of the riding-area.

During the figure the grip connections have to be released simultaneously and in motion. Each rider performs 3 spinnings simultaneously and on the same axis. After the spinnings the riders have to close the grip connection simultaneously and in motion. Before releasing and after closing the grip connection the wingmill has to be performed at least 2 metres.

The figure ends not before a complete surrounding around the centre of the riding-area is performed.

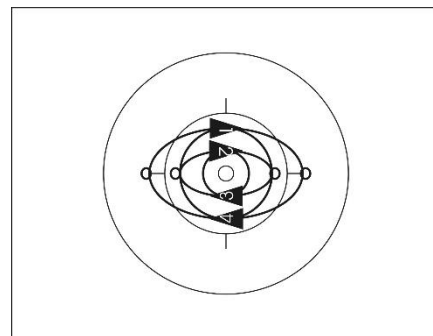

4024 b

Spinnings (8.3.037)

Remmlinger Spinnings

Starting position is the 2 connected wingmill. During the figure all grip connections have to be released simultaneously. After releasing the grip connections all riders perform 3 spinnings on an imaginary axis which leads through the middle of the riding-area. After completing the spinnings the inside riders perform a mill, connected with their left hands above the middle of the riding-area for at least a way of stretch of a complete circle. Then the two riders release the grip connection again and all riders will perform, simultaneously 1 spinning on an imaginary axis which leads through the middle of the riding-area. The outside riders will show continuous spinnings from the first spinnings until the last required spinning of this figure. The figure ends with a simultaneous performed hand-in-hand grip connection to the position two mills.

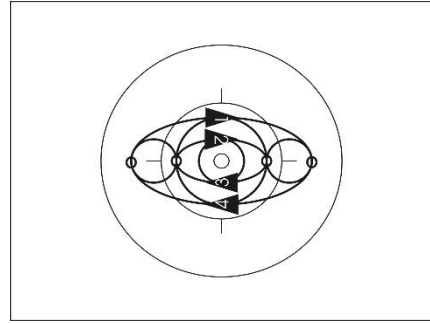

4024 c

2 connected wingmill

Two riders of each group are connected by grip connection and are riding side by side on an axis. The distances between rider 1 and 2 has to be identical to the distances of riders 3 and 4. Both groups are riding with same distances between each other on the same axis, while riding at the same distances around the centre of the riding-area. The inside riders of the groups are connected to each other by their left hands, above the centre of the riding-area.

Spinnings (8.3.037)

Two Mills

Each two riders are riding at equal distances following each other around a spot on the riding-area. The used spots for the mills have the same distances to the centre of the riding-area and are situated on the longitudinal axis. The riders of each group are connected with their left hands. The riding-area will be divided by the transverse axis. The mills will start as soon as the grip connections are closed. Each 2 riders (one of each group) are riding on the same longitudinal axis during the figure.

2 following each other half double circle

Each 2 riders following each other with same distances to each other while both are surrounding the same point on the riding-area. The centre of each point (one for each group) is situated the same distance to the centre of the riding-area on the longitudinal axis. Each two riders (one of each group) are riding on the same longitudinal axis during the figure. This axis runs parallel towards the long side of the riding-area during the whole way of stretch of the circle.

The riding-area is divided by the transverse axis. The diametre of each circle of the double circle has to be at least 4 metres. The figure ends when the point is surrounded half.

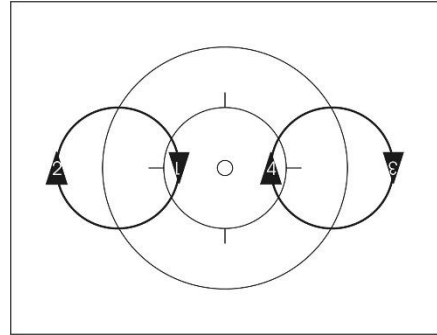

4026 a
4027 a
4028 a
4028 c
4029 a

2 following each other double circle

Each 2 riders following each other at the same distances to each other while both are surrounding the same point on the riding-area. The centre of each point (one for each group) is situated the same distance to the centre of the riding-area on the longitudinal axis. Each two riders (one of each group) are riding on the same longitudinal axis during the figure. This axis runs parallel towards the long side of the riding-area during the whole way of stretch of the circle.

The riding-area is divided by the transverse axis. The diametre of each circle of the double circle has to be at least 4 metres. The figure ends when the point is surrounded completely.

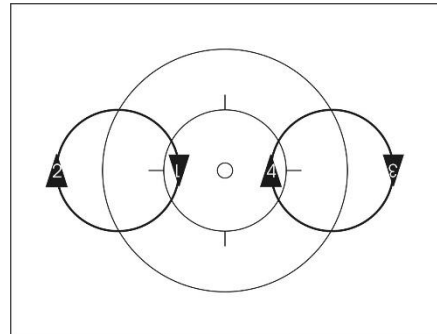

4026 b
4027 b
4028 b
4028 d
4029 b

2 following each other half double circle 4 single rings left

Each 2 riders following each other at the same distances to each other while both are surrounding the same point on the riding-area. The centre of each point (one for each group) is situated the same distance to the centre of the riding-area on the longitudinal axis. Each two riders (one of each group) are riding on the same longitudinal axis during the figure. This axis runs parallel towards the long side of the riding-area during the whole way of stretch of the circle. The riding-area is divided by the transverse axis. The diameter of each circle of the double circle has to be at least 4 metres. During the figure, each rider performs simultaneously a same sized and uniform single ring left. The half double circle has to be performed 2 metres before and 2 metres after the single ring left. The figure ends when the point is surrounded half.

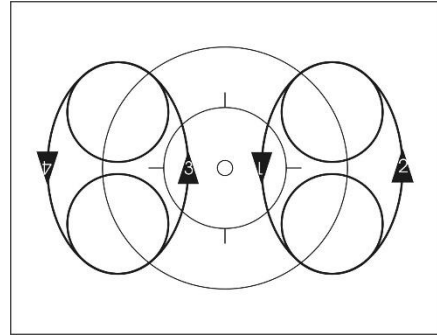

4026 c
4027 c
4028 e
4028 g
4029 c

Single ring left (8.3.029)

2 following each other double circle 4 single rings left

Each 2 riders following each other at the same distances to each other while both are surrounding the same point on the riding-area. The centre of each point (one for each group) is situated the same distance to the centre of the riding-area on the longitudinal axis. Each two riders (one of each group) are riding on the same longitudinal axis during the figure. This axis runs parallel towards the long side of the riding-area during the whole way of stretch of the circle. The riding-area is divided by the transverse axis. The diameter of each circle of the double circle has to be at least 4 metres. During the figure, each rider performs simultaneously a same sized and uniform single ring left. The half double circle has to be performed 2 metres before and 2 metres after the single ring left. The figure ends when the point is surrounded completely.

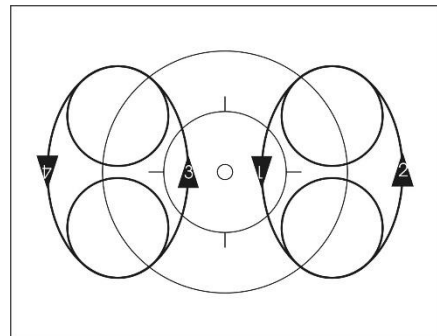

4026 d
4027 d
4028 f
4028 h
4029 d

Single ring left (8.3.029)

2 following each other shortline

Each 2 riders are riding next to each other without grip connection. Rider 1 and 3 and rider 2 and 4 are riding on the same axis parallel to the short side of the riding-area. Rider 1 and 2 and rider 3 and 4 are riding on the same axis which runs parallel to the long side of the riding-area. The distance between the riders which are following each other may not be more than 2 metres. The way of stretch for all shortline figures will start 1 metre from the long side of the riding-area until 1 metre distance before the opposite border of the riding-area.

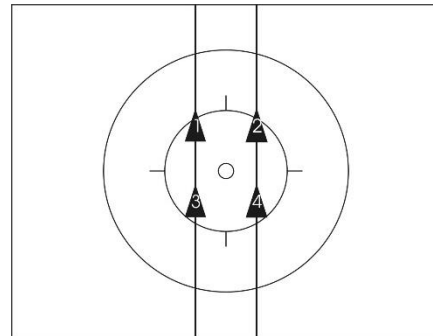

4031 a
4032 a

2 following each other shortline 4 single rings left

Each 2 riders are riding next to each other without grip connection. Rider 1 and 3 and rider 2 and 4 are riding on the same axis parallel to the short side of the riding-area. Rider 1 and 2 and rider 3 and 4 are riding on the same axis which runs parallel to the long side of the riding-area. The distance between the riders which are following each other may not be more than 2 metres. During the figure, each rider performs a single ring left simultaneously and uniform. The shortline has to be performed at least 2 metres before and 2 metres after the single ring left.

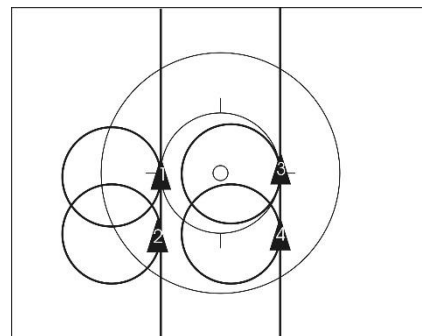

4031 b
4032 b

The way of stretch for all shortline figures will start 1 metre from the long side of the riding-area until 1 metre distance before the opposite border of the riding-area.

Single ring left (8.3.029)

2 next to each other short line opposite direction

Each 2 riders are riding next to each other without grip connection on an axis which runs parallel to the long side of the riding-area. The distance between rider 1 and 2 must be identical to the distance between riders 3 and 4. All riders are riding on an axis parallel to the short side of the riding-area. One group will start from the long side of the riding-area and ride to the opposite side of the riding-area. The other group will start from the other long side and will ride to the opposite side of the riding-area. Both groups are riding with the same speed during this figure. The way of stretch for all shortline figures will start 1 metre from the long side of the riding-area until 1 metre distance before the opposite border of the riding-area.

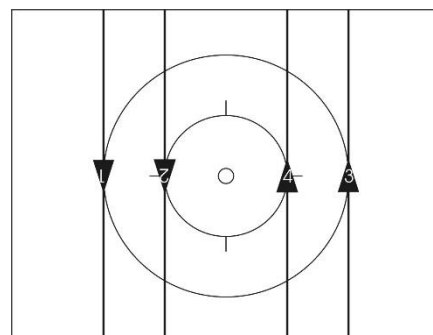

4044 a
4045 a
4047 a
4047 b

**2 next to each other shortline
opposite direction 4 s.r.l.**

Each 2 riders are riding next to each other without grip connection on one axis which runs parallel to the long side of the riding-area. The distance between rider 1 and 2 must be identical to the distance between riders 3 and 4. All riders are riding on an axis parallel to the short side of the riding-area. One group will start from the long side of the riding-area and ride to the opposite side of the riding-area. The other group will start from the other long side and will ride to the opposite side of the riding-area. Both groups are riding with the same speed during this figures. During the figure, each athlete performs a single ring left simultaneously and uniform. The shortline has to be performed 2 metres before and 2 metres after the single ring left. The way of stretch for all shortline figures will start 1 metre from the long side of the riding-area until 1 metre distance before of the opposite border of the riding-area.

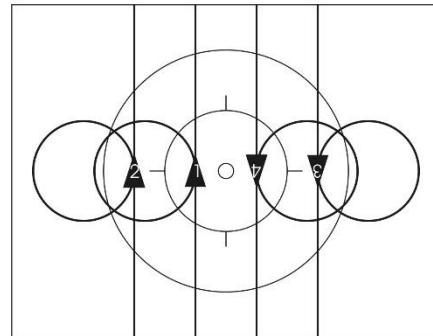

4044 b

Single ring left (8.3.029)

**2 next to each other shortline
opposite direction through**

Each 2 riders are riding next to each other without grip connection on an axis which runs parallel to the long side of the riding-area. The distance between rider 1 and 2 must be identical to the distance between riders 3 and 4. All riders are riding on an axis parallel to the short side of the riding-area. One group will start from the long side of the riding-area and ride to the opposite side of the riding-area. The other group will start from the other long side and will ride to the opposite side of the riding-area. Both groups are riding with the same speed during this figure. Half way, at the middle of the riding-area, one rider of each group, will ride through the space between the two facing riders. The way of stretch for all short line exercises will start 1 metre from the long side of the riding-area until 1 metre distance before the opposite border of the riding-area.

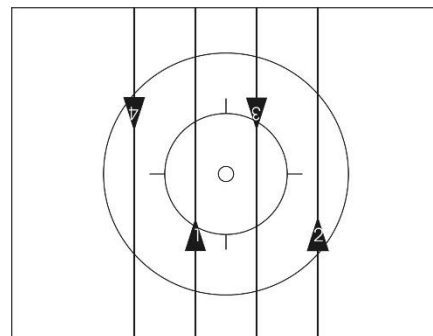

4044 c
4045 b
4047 c
4047 d

2 next to each other shortline opposite direction through 4 single rings left

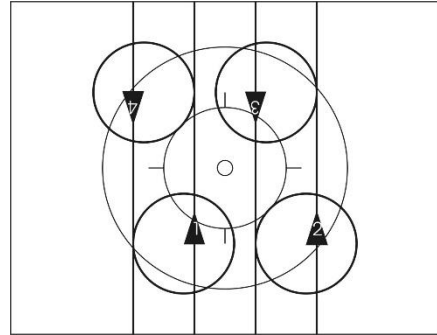

4044 d

Each 2 riders are riding next to each other without grip connection on an axis which runs parallel to the long side of the riding-area. The distance between rider 1 and 2 must be identical to the distance between riders 3 and 4. All riders are riding on an axis parallel to the short side of the riding-area. One group will start from the long side of the riding-area and ride to the opposite side of the riding-area. The other group will start from the other long side and will ride to the opposite side of the riding-area. Both groups are riding with the same speed during this figure. Half way, at the middle of the riding-area, one rider of each group, will ride through the space between the two facing riders. During the figure, each rider performs a single ring left simultaneously and uniform. The shortline has to be performed at least 2 metres before and 2 metres after the single ring left.

The way of stretch for all shortline figures will start 1 metre from the long side of the riding-area until 1 metre distance before the opposite border of the riding-area.

Single ring left (8.3.029)

2 next to each other shortline opposite half counter single ring

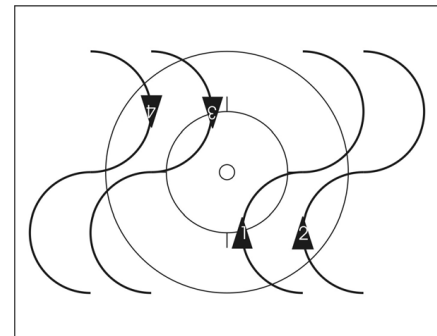

4044 e
4045 c
4047 e

Each 2 riders are riding next to each other without grip connection on an axis which runs parallel to the long side of the riding-area. The distance between rider 1 and 2 must be identical to the distance between riders 3 and 4. Both groups of riders perform a half counter single ring. Both groups are riding with the same speed during this figure. One group will start from the long side of the riding-area and ride to the opposite side of the riding-area. The other group will start from the other long side and will ride to the opposite side of the riding-area.

Half counter single ring (8.3.031)

2 next to each other shortline opposite counter single ring

Each 2 riders are riding next to each other without grip connection on an axis which runs parallel to the long side of the riding-area. The distance between rider 1 and 2 must be identical to the distance between riders 3 and 4. Both groups of riders perform a counter single ring. Both groups are riding with the same speed during this figure. One group will start from the long side of the riding-area and ride to the opposite side of the riding-area and back. The other group will start from the other long side and will ride to the opposite side of the riding-area and back.

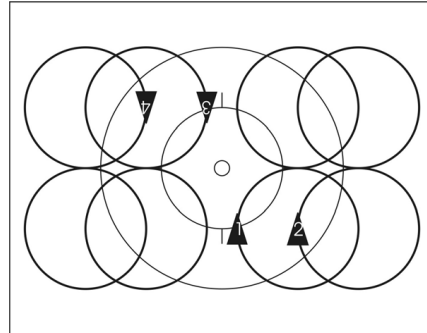

4044 f
4045 d
4047 f

Counter single ring (8.3.032)

2 next to each other shortline opposite direction counter single ring through

4047 g

Each 2 riders are riding next to each other without grip connection on an axis which runs parallel to the long side of the riding-area. The distance between rider 1 and 2 has to be identical to the distance between riders 3 and 4. Both groups of riders perform a counter single ring. Both groups are riding with the same speed during this figure. One group will start from the long side of the riding-area and ride to the opposite side of the riding-area and back. The other group will start from the other long side and will ride to the opposite side of the riding-area and back. During the figure all riders are riding on the longitudinal axis and they are riding through the space which is built from two riders. During the "riding through the space" all riders have to be situated within the 4-metre-circle.

Shortline opposite direction counter single ring through

Each 2 riders are riding next to each other without grip connection on an axis which runs parallel to the long side of the riding-area. Both groups of riders perform a counter single ring (without defined diameter, but all single rings must have the same size). One group will start from the long side of the riding-area and ride to the opposite side of the riding-area and back. The other group will start from the other long side and will ride to the opposite side of the riding-area and back. In the middle of the riding-area the groups have to cross twice.

2 connected half circle

Each two riders are riding side by side with grip connection they build a group of riders. The distance between rider 1 and two has to be identical to the distance between rider 3 and 4. Both groups are riding with same distance to each other and at same distance to the 4-metre-circle, at the outside of the 4-metre-circle.

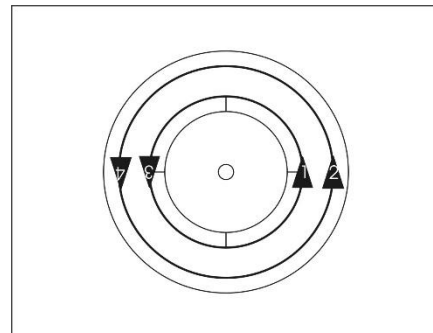

4071 a
4072 a
4073 a
4073 c
4074 a

The figure ends when the 4-metre-circle is rounded half at the outside of the 4-metre-circle.

2 connected circle

Each two riders are riding side by side with grip connection they build a group of riders. The distance between rider 1 and two has to be identical to the distance between rider 3 and 4. Both groups are riding with same distance to each other and at same distance to the 4-metre-circle, at the outside of the 4-metre-circle. The figure ends when the 4-metre-circle is rounded completely at the outside of the 4-metre-circle.

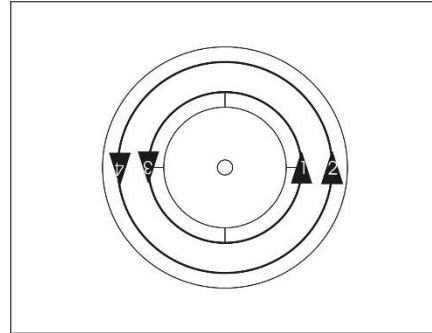

4071 b
4072 b
4073 b
4073 d
4074 b

2 connected half circle 2 connected single ring left

Each two riders are riding side by side with grip connection they build a group of riders. The distance between rider 1 and two has to be identical to the distance between rider 3 and 4. Both groups are riding with same distance to each other and at same distance to the 4-metre-circle, at the outside of the 4-metre-circle.

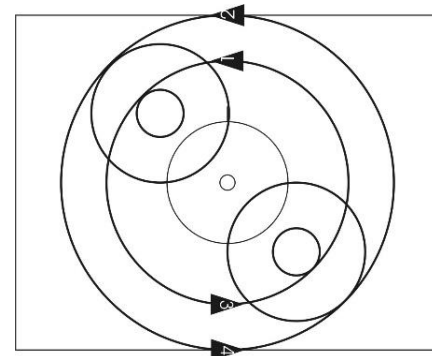

4071 c
4072 c
4073 e
4073 g
4074 c

The two groups of riders perform simultaneously a 2 connected single ring left with the same size and uniform.

The half circle has to be performed 2 metres before and 2 metres after the single ring left.

The figure ends when the 4-metre-circle is rounded half at the outside of the 4-metre-circle.

2 connected single ring left (8.3.033)

2 connected circle 2 connected single ring left

Each two riders are riding side by side with grip connection they build a group of riders. The distance between rider 1 and two has to be identical to the distance between rider 3 and 4. Both groups are riding with same distance to each other and at same distance to the 4-metre-circle, at the outside of the 4-metre-circle.

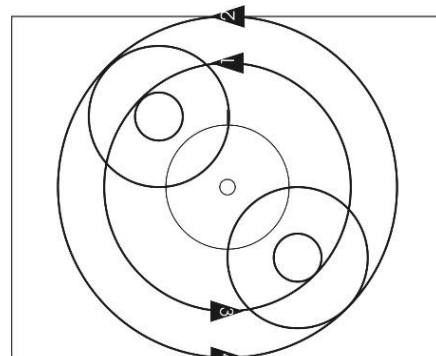

4071 d
4072 d
4073 f
4073 h
4074 d

The two groups of riders perform simultaneously a 2 connected single ring left with the same size and uniform.

The circle has to be performed 2 metres before and 2 metres after the single ring left.

The figure ends when the 4-metre-circle is rounded completely at the outside of the 4-metre-circle.

2 connected single ring left (8.3.033)

2 connected half circle 4 single rings left

Each two riders are riding side by side with grip connection they build a group of riders. The distance between rider 1 and two has to be identical to the distance between rider 3 and 4. Both groups are riding at same distance to each other and at same distance to the 4-metre-circle, at the outside of the 4-metre-circle.

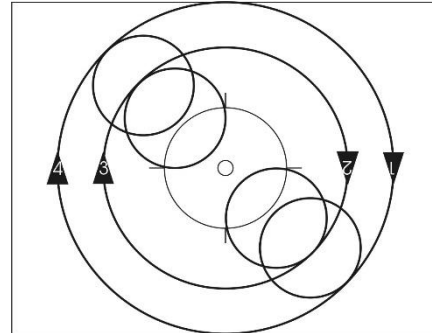

4071 e
4072 e
4073 i
4073 k
4074 e

During the figure, the grip connections have to be released simultaneously and in motion. Each rider performs a single ring left simultaneously and uniform.

After the single rings left, the athletes have to close the grip connections simultaneously and in motion.

The half circle has to be performed 2 metres before and 2 metres after the single ring left.

The figure ends when the 4-metre-circle is rounded half at the outside of the 4-metre-circle.

Single ring left (8.3.029)

2 connected circle 4 single rings left

Each two riders are riding side by side with grip connection they build a group of riders. The distance between rider 1 and two has to be identical to the distance between rider 3 and 4. Both groups are riding at same distance to each other and at same distance to the 4-metre-circle, at the outside of the 4-metre-circle.

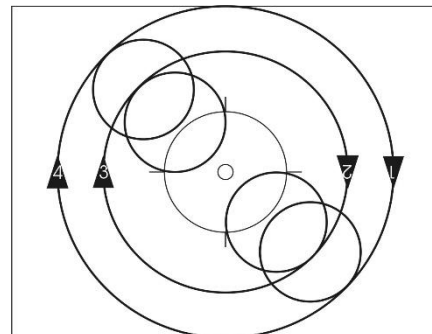

4071 f
4072 f
4073 j
4073 l
4074 f

During the figure, the grip connections have to be released simultaneously and in motion. Each rider performs a single ring left simultaneously and uniform.

After the single rings left, the riders have to close the grip connections simultaneously and in motion.

The circle has to be performed 2 metres before and 2 metres after the single ring left.

The figure ends when the 4-metre-circle is rounded completely at the outside of the 4-metre-circle.

Single ring left (8.3.029)

**2 connected half circle 4 single rings left through /
2 connected circle 4 single rings left through**

**4073m
4073 n
4073 o
4073 p
4074 g
4074 h**

Each two riders are connected to each other with a grip connection. The distance between rider 1 and 2 has to be identical to the distance between rider 3 and 4. Both groups are riding at same distance from each other and at same distance from the 4-metre-circle, at the outside of the 4-metre-circle. During the figure the grip connections have to be released simultaneously and in motion. Each rider performs a single ring left simultaneously and uniform to the other riders. The single rings left of the inside riding riders have to overlap. After the single rings left, the riders have to close the grip connection simultaneously and in motion.

The half circle / circle has to be performed 2 metres before and 2 metres after the single ring left.

The figure ends when the 4-metre-circle is rounded half / completely at the outside of the 4-metre-circle.

Single ring left through (8.3.029)

**2 connected following each other
longline**

Each 2 riders are connected to each other with grip connection. Rider 1 and 3 and rider 2 and 4 are following each other, riding on the same axis parallel to the long side of the riding-area. Rider 1 and 2 and rider 3 and 4 are riding as group on the same axis which runs parallel to the short side of the riding-area. The way of stretch for all longline figures will start at 1 metre from the short side of the riding-area until 1 metre before the opposite border of the riding-area.

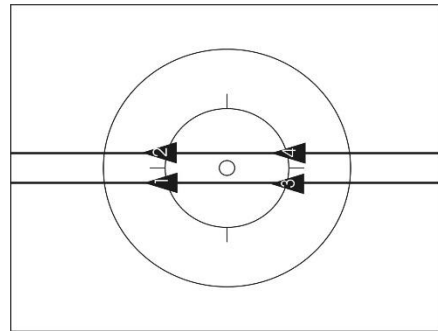

4082 a

**2 connected following each other
longline 2 single rings left 2 single
rings right**

4082 b

Each 2 riders are connected to each other with grip connection. Rider 1 and 3 and rider 2 and 4 are following each other, riding on the same axis which runs parallel to the long side of the riding-area. Rider 1 and 2 and rider 3 and 4 are riding on the same axis parallel to the short side of the riding-area.

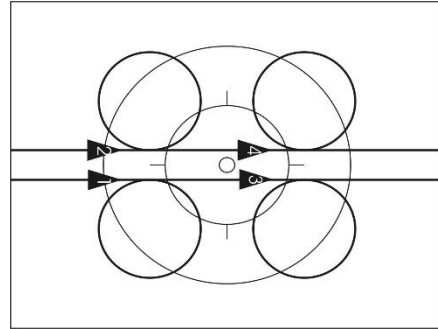

During the figure, the grip connections have to be released simultaneously and in motion, the riders have to perform 2 single rings left and 2 single rings right with the same size and uniform. Rider 1 and 3 and rider 2 and 4 have to perform the same type of single ring. After the single rings, the riders have to close the grip connections simultaneously and in motion.

The figure has to be performed 2 metres before and 2 metres after the single ring left. The way of stretch for all longline figures will start 1 metre from the short side of the riding-area until 1 metre before the opposite border of the riding-area.

Single ring left (8.3.029)

Single ring right (8.3.030)

**2 connected longline opposite
direction 4 single rings right
through**

4082 c

Each 2 riders are connected to each other with grip connection and are riding next to each other on an axis which runs parallel to the short side of the riding-area. The distance between rider 1 and 2 must be identical to the distance between riders 3 and 4. All riders are riding on an axis parallel to the long side of the riding-area. One group will start from the short side of the riding-area and ride to the opposite side of the riding-area. The other group will start from the other short side and will ride to the opposite side of the riding-area. During the figure the grip connections will all released simultaneously while riding and one rider of each group, will ride through the space between the two facing riders. Being all on one line all riders will perform, simultaneous a same shaped, single ring right; all with the same diametre. After performing the single rings, being again on one line, the groups will connect again, simultaneously and in motion. After being connected again the riders will finish the longline. The way of stretch for all longline figures will start 1 metre from the short side of the riding-area until 1 metre before the opposite border of the riding-area.

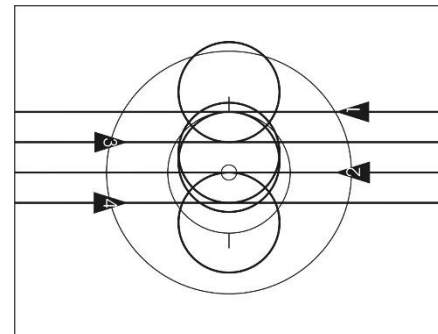

During the figure, the grip connections will all released simultaneously while riding and one rider of each group, will ride through the space between the two facing riders. Being all on one line all riders will perform, simultaneous a same shaped, single ring right; all with the same diametre. After performing the single rings, being again on one line, the groups will connect again, simultaneously and in motion. After being connected again the riders will finish the longline. The way of stretch for all longline figures will start 1 metre from the short side of the riding-area until 1 metre before the opposite border of the riding-area.

Single ring right (8.3.030)

2 connected shortline

Each 2 riders are connected to each other with grip connection. Each rider is riding on an axis parallel to the short side of the riding-area. The distance between rider 1 and 2 must be identical to the distance between riders 3 and 4. All riders are riding on the same axis which runs parallel to the long side of the riding-area. The way of stretch for all shortline figures will start at 1 metre from the ~~short~~ long side of the riding-area until 1 metre before the opposite border of the riding-area.

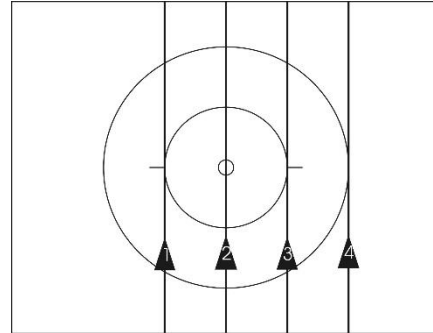

4086 a
4087 a
4088 a
4088 b
4089 a

2 connected shortline 2 connected single rings left

Each 2 riders are connected to each other with grip connection. Each rider is riding on an axis parallel to the short side of the riding-area. The distance between rider 1 and 2 must be identical to the distance between riders 3 and 4. All riders are riding on the same axis which runs parallel to the long side of the riding-area.

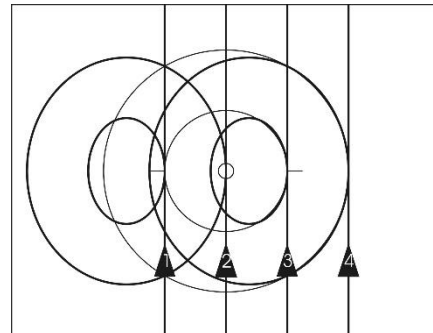

4086 b
4087 b
4088 c
4088 d
4089 b

During the figure the two groups of riders perform simultaneously a 2 connected single ring left with same size and uniform. The figure has to be performed 2 metres before and 2 metres after the single ring left. The way of stretch for all shortline figures will start 1 metre distance from the ~~short~~ long side of the riding-area until 1 metre before the opposite border of the riding-area.

2 connected single ring left (8.3.033)

2 connected shortline 2 connected single rings right

Each 2 riders are connected to each other with grip connection. Each rider is riding on an axis parallel to the short side of the riding-area. The distance between rider 1 and 2 must be identical to the distance between riders 3 and 4. All riders are riding on the same axis which runs parallel to the long side of the riding-area.

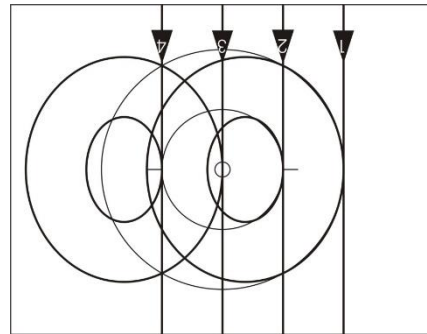

4086 c

During the figure the two groups of riders perform simultaneously a 2 connected single ring right with same size and uniform.

The figure has to be performed 2 metres before and 2 metres after the single ring left.

The way of stretch for all shortline figures will start 1 metre from the **short long** side of the riding-area until 1 metre before the opposite border of the riding-area.

2 connected single ring right (8.3.034)

2 connected shortline 4 single rings left

Each 2 riders are connected to each other with grip connection. Each rider is riding on an axis parallel to the short side of the riding-area. The distance between rider 1 and 2 must be identical to the distance between riders 3 and 4. All riders are riding on the same axis which runs parallel to the long side of the riding-area.

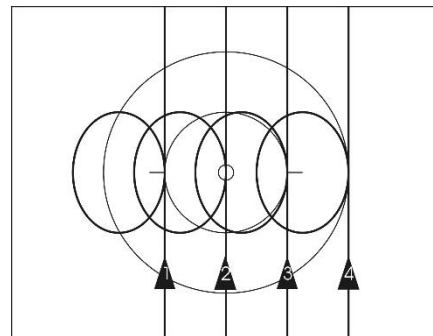

4086 d
4087 c
4088 e
4088 f
4089 c

During the figure, the grip connections have to be released simultaneously and in motion. Each rider performs simultaneously a single ring left with same size and uniform.

After the single rings left, the riders have to restore the grip connections simultaneously and in motion.

The shortline has to be performed 2 metres before and 2 metres after the single ring left.

The way of stretch for all shortline figures will start 1 metre from the **short long** side of the riding-area until 1 metre before the opposite border of the riding-area.

Single ring left (8.3.029)

2 connected shortline half counter single ring

Each 2 riders are riding as a group next to each other with closed grip connection. The distance between rider 1 and 2 must be identical to the distance between riders 3 and 4. Both groups are on an axis which runs parallel to the long side of the riding-area. Both groups of riders perform a half counter single ring.

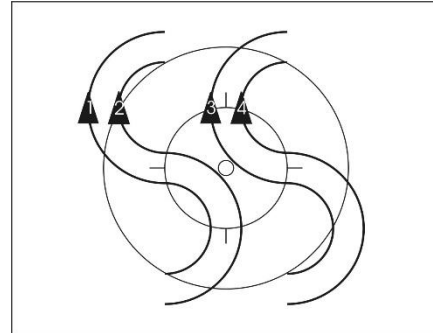

4096 a
4097 a
4098 a
4098 c
4099 a

Half counter single ring (8.3.031)

2 connected shortline counter single ring

Each 2 riders are riding as a group next to each other with closed grip connection. The distance between rider 1 and 2 must be identical to the distance between riders 3 and 4. Both groups are on an axis which runs parallel to the long side of the riding-area. Both groups of riders perform a counter single ring.

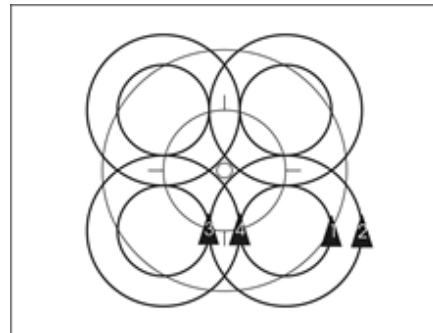

4096 b
4097 b
4098 b
4098 d
4099 b

Counter single ring (8.3.032)

2 connected shortline opposite

Each 2 riders are connected to each other with grip connection. Each rider is riding on an axis parallel to the short side of the riding-area. The distance between rider 1 and 2 must be identical to the distance between riders 3 and 4. All riders are riding on the same axis which runs parallel to the long side of the riding-area. One group will start from the long side of the riding-area and ride to the opposite side of the riding-area. The other group will start from the other long side and will ride to the opposite side of the riding-area. Both groups are riding with same speed during this figure. The way of stretch for all shortline figures will start 1 metre from the **short long** side of the riding-area until 1 metre before the opposite border of the riding-area.

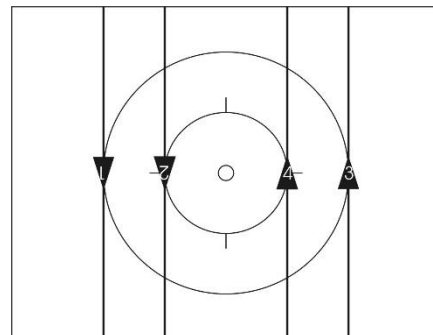

4105 a
4106 a
4107 a
4107 b
4108 a

2 connected shortline opposite 2 connected single rings left

Each 2 riders are connected to each other with grip connection. Each rider is riding on an axis parallel to the short side of the riding-area. The distance between rider 1 and 2 must be identical to the distance between riders 3 and 4. All riders are riding on the same axis which runs parallel to the long side of the riding-area. One group will start from the long side of the riding-area and ride to the opposite side of the riding-area. The other group will start from the other long side and will ride to the opposite side of the riding-area. Both groups are riding with same speed during this figure.

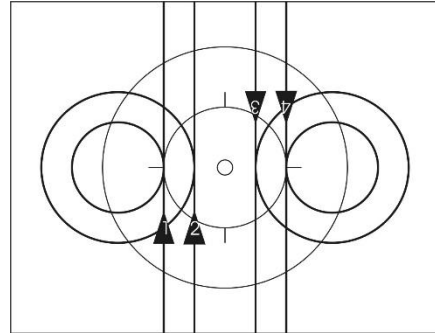

4105 b
4106 b
4107 c
4107 d

During the figure the two groups of riders perform simultaneously and uniform a 2 connected single ring left.

The figure has to be performed 2 metres before and 2 metres after the single ring left.

The way of stretch for all shortline figures will start 1 metre from the **short long** side of the riding-area until 1 metre before the opposite border of the riding-area.

2 connected single ring left (8.3.033)

2 connected shortline opposite 4 single rings left

Each 2 riders are connected to each other with grip connection. Each rider is riding on an axis parallel to the short side of the riding-area. The distance between rider 1 and 2 must be identical to the distance between riders 3 and 4. All riders are riding on the same axis which runs parallel to the long side of the riding-area. One group will start from the long side of the riding-area and ride to the opposite side of the riding-area. The other group will start from the other long side and will ride to the opposite side of the riding-area. Both groups are riding with same speed during this figure.

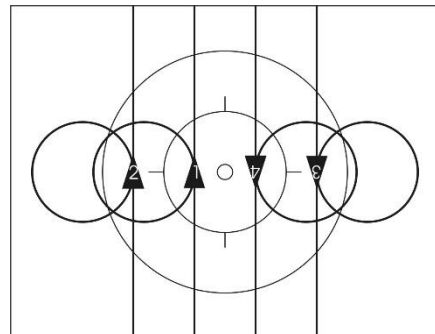

4105 c
4106 c
4107 e
4107 f
4108 b

During the figure, the grip connections have to be released simultaneously and in motion. Each rider performs a single ring left simultaneously and uniform.

After the single rings left, the riders have to close the grip connections simultaneously and in motion.

The shortline has to be performed 2 metres before and 2 metres after the single ring left.

The way of stretch for all shortline figures will start 1 metre from the **short long** side of the riding-area until 1 metre before the opposite border of the riding-area.

Single ring left (8.3.029)

Surrounding 1 around 1

Each two riders are riding next to each other, are connected by hand-in-hand-grip and form two groups of riders. The two groups are riding on, the same, imaginary axis, through the middle of riding-area. The inside rider is standing, without pedalling, on a spot, while the partner is riding a complete circle around the inside rider. The figure ends after a complete circle around the surrounding rider.

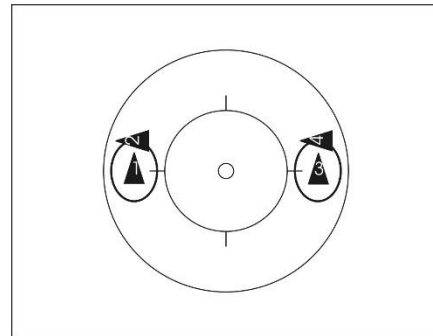

4116 a
4117 a

Two mills

Each two riders are riding at equal distances following each other around a spot on the riding-area. Each two riders are connected with their left hands. Both spots are located on the longitudinal axis with the same distances from the centre of the riding-area. The mills will start as all riders are connected with their left hands. Each 2 riders (one of each group) are riding on the same longitudinal axis during the figure, which runs parallel to the long side of the riding-area. The figure ends after a complete surrounding and reaching the starting position again.

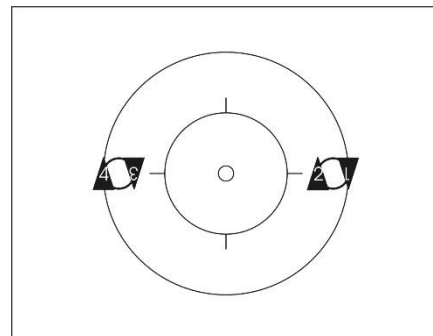

4121 a
4122 a
4122 b
4122 c
4123 a
4123 b
4123 c
4123 d
4123 e
4123 f
4124 a
4124 b
4124 c

Two mills 4 single rings right

Each two riders are riding at equal distances following each other around a spot on the riding-area. Each two riders are connected with their left hands. Both spots are located on the longitudinal axis with the same distances from the centre of the riding-area. The mills will start as all riders are connected with their left hands. Each 2 riders (one of each group) are riding on the same longitudinal axis during the figure, which runs parallel to the long side of the riding-area.

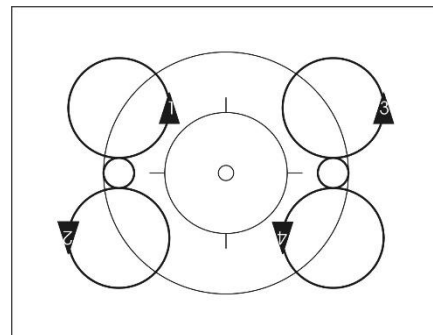

4121 b
4124 d

During the figure the grip connections have to be released simultaneously and in motion. Each rider performs simultaneously a single ring right with same size and uniform. After the single rings the riders have to close the grip connection simultaneously and in motion.

The mills have to be performed 2 metres before and 2 metres after the single ring right.

The figure ends after a complete surrounding and reaching the starting position again.

Single ring right (8.3.030)

Two inside rings

Each two riders are riding at equal distances following each other around a spot at the riding-area. Each rider of each group is connected with his right hand the left hand and with the left hand the right hand of his partner. Both spots are located on the longitudinal axis with the same distances from the centre of the riding-area. The rings will start as all riders are connected. Each 2 riders (one of each group) are riding on the same longitudinal axis during the figure, which runs parallel to the long side of the riding-area. The figure ends after a complete surrounding and reaching the starting position again.

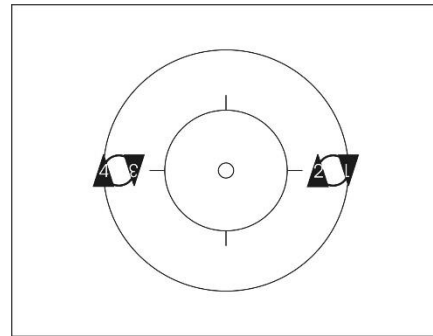

4133 a
4133 b
4133 c
4133 d
4133 e
4134 a
4134 b
4134 c

Two mills 3 spinnings

Each two riders are riding at equal distances following each other around a spot on the riding-area. The riders of each group are connected with their left hands. The mills will start as all riders are connected. Each 2 riders (one of each group) are riding on the same longitudinal axis during the figure, which runs parallel to the long side of the riding-area.

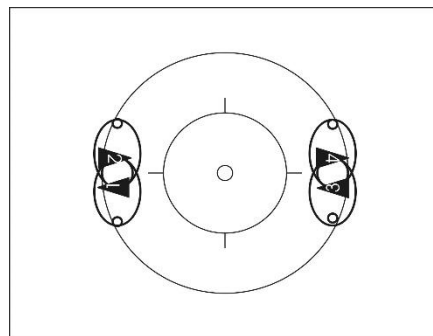

4134 d

During the figure the grip connections of each group has to be released simultaneously and in motion. Each rider performs simultaneously 3 spinnings. After the spinnings the riders have to close the grip connection simultaneously and in motion.

The figure has to be performed 2 metres before and 2 metres after the spinnings.

The figure ends after a complete surrounding and reaching the starting position again.

Spinnings (8.3.037)

Two inside rings 3 spinnings

Each two riders are riding at equal distances following each other around a spot at the riding-area. Each rider of each group is connected with his right hand the left hand and with the left hand the right hand of his partner. Both spots are located on the longitudinal axis with the same distances from the centre of the riding-area. The rings will start as all riders are connected. Each 2 riders (one of each group) are riding on the same longitudinal axis during the figure, which runs parallel to the long side of the riding-area.

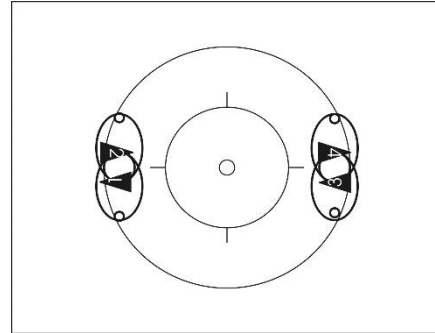

4134 e

During the figure the grip connections of each group have to be released simultaneously and in motion. Each rider performs simultaneously 3 spinnings. After the spinnings the riders have to close the grip connection simultaneously and in motion.

The figure has to be performed 2 metres before and 2 metres after the spinnings.

The figure ends after a complete surrounding and reaching the starting position again.

Spinnings (8.3.037)

Two outside rings

Each two riders are riding at equal distances following each other around a spot on the riding-area. Each rider of each group grabs with his left hand the right hand of his partner. Both spots are located on the longitudinal axis with the same distances from the centre of the riding-area. The rings will start when all riders are connected. Each two riders (one of each group) are riding on the same longitudinal axis during the figure, which runs parallel to the long side of the riding-area. The figure ends after a complete surrounding and once the riders reach the starting position.

4135 a
4135 b
4135 c
4135 d
4135 e
4136 a
4136 b
4136 c

4 connected half circle

All riders are riding with closed grip connection side by side on an axis, which goes through the center of the riding-area, around the 4-metre-circle. The distance between rider 1 and rider 2, the distance between rider 2 and rider 3 and the distance between rider 3 and rider 4 has to be identical.

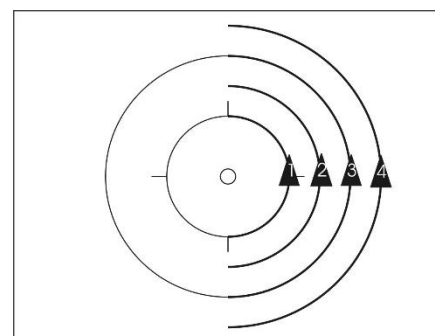

4151 a
4152 a
4153 a
4153 c
4154 a

The figure ends when the 4-metre-circle is rounded half at the outside of the 4-metre-circle.

4 connected circle

All riders are riding with closed grip connection side by side on an axis, which goes through the center of the riding-area, around the 4-metre-circle. The distance between rider 1 and rider 2, the distance between rider 2 and rider 3 and the distance between rider 3 and rider 4 has to be identical. The figure ends, when the 4-metre-circle is rounded completely at the outside of the 4-metre-circle.

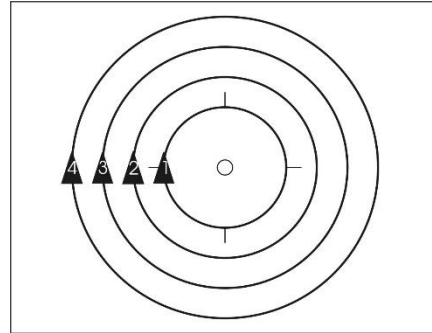

4151 b
4152 b
4153 b
4153 d
4154 b

4 connected half circle 2 connected single rings left

All riders are riding with closed grip connection side by side on an axis, which goes through the center of the riding-area, around the 4-metre-circle. The distance between rider 1 and rider 2, the distance between rider 2 and rider 3 and the distance between rider 3 and rider 4 has to be identical.

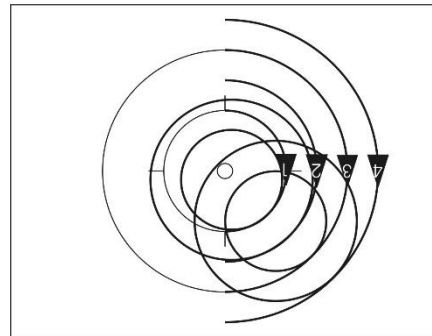

4151 c
4152 c
4153 e
4153 g
4154 c

During the figure the grip connection between rider 2 and 3 has to be released. The two groups of riders perform simultaneously and uniform a 2 connected single ring left. The figure has to be performed 2 metres before and 2 metres after the single ring left.

The figure ends when the 4-metre-circle is rounded half at the outside of the 4-metre-circle.

2 connected single ring left (8.3.033)

4 connected circle 2 connected single rings left

All riders are riding with closed grip connection side by side on an axis, which goes through the center of the riding-area, around the 4-metre-circle. The distance between rider 1 and rider 2, the distance between rider 2 and rider 3 and the distance between rider 3 and rider 4 has to be identical.

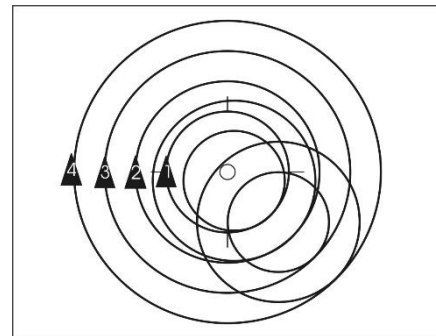

4151 d
4152 d
4153 f
4153 h
4154 d

During the figure the grip connection between rider 2 and 3 has to be released. The two groups of riders perform simultaneously and uniform a 2 connected single ring left. The figure has to be performed 2 metres before and 2 metres after the single ring left.

The figure ends when the 4-metre-circle is rounded completely at the outside of the 4-metre-circle.

2 connected single ring left (8.3.033)

4 connected half circle 4 single rings left

All riders are riding with closed grip connection side by side on an axis, which goes through the center of the riding-area, around the 4-metre-circle. The distance between rider 1 and rider 2, the distance between rider 2 and rider 3 and the distance between rider 3 and rider 4 has to be identical.

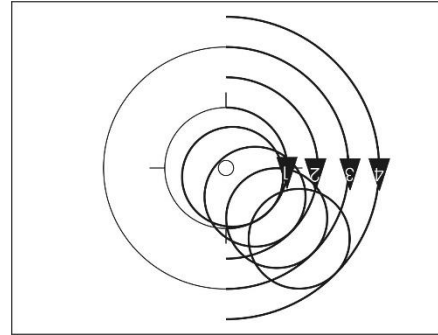

4151 e
4152 e
4153 i
4153 k
4154 e

During the figure the grip connections between all riders have to be released simultaneously and in motion. All riders perform simultaneously and uniform a single ring left. The figure has to be performed 2 metres before and 2 metres after the single rings left.

The figure ends when the 4-metre-circle is rounded half at the outside of the 4-metre-circle.

Single ring left (8.3.029)

4 connected circle 4 single rings left

All riders are riding with closed grip connection side by side on an axis, which goes through the center of the riding-area, around the 4-metre-circle. The distance between rider 1 and rider 2, the distance between rider 2 and rider 3 and the distance between rider 3 and rider 4 has to be identical.

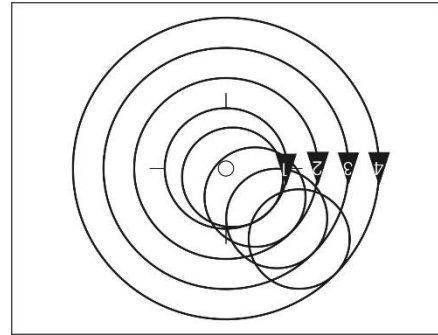

4151 f
4152 f
4153 j
4153 l
4154 f

During the figure the grip connections between all riders have to be released simultaneously and in motion. All riders perform simultaneously and uniform a single ring left. The figure has to be performed 2 metres before and 2 metres after the single rings left.

The figure ends when the 4-metre-circle is rounded completely at the outside of the 4-metre-circle.

Single ring left (8.3.029)

4 connected half circle 3 spinnings

All riders are riding with closed grip connection side by side on an axis, which goes through the center of the riding-area, around the 4-metre-circle. The distance between rider 1 and rider 2, the distance between rider 2 and rider 3 and the distance between rider 3 and rider 4 has to be identical. During the figure the grip connections have to be released simultaneously and in motion. Each rider performs simultaneously 3 spinnings. After the spinnings riders have to close the grip connection simultaneously and in motion.

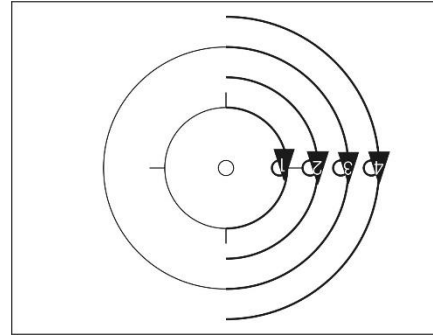

4154 g

The figure has to be performed 2 metres before and 2 metres after the spinnings.

The figure ends when the 4-metre-circle is rounded half at the outside of the 4-metre-circle.

Spinings (8.3.037)

4 connected circle 3 spinnings

All riders are riding with closed grip connection side by side on an axis, which goes through the center of the riding-area, around the 4-metre-circle. The distance between rider 1 and rider 2, the distance between rider 2 and rider 3 and the distance between rider 3 and rider 4 has to be identical.

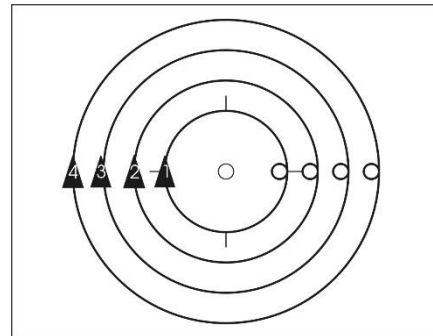

4154 h

During the figure the grip connections have to be released simultaneously and in motion. Each rider performs simultaneously 3 spinnings. After the spinnings riders have to close the grip connection simultaneously and in motion.

The figure has to be performed 2 metres before and 2 metres after the spinnings.

The figure ends when the 4-metre-circle is rounded completely at the outside of the 4-metre-circle.

Spinings (8.3.037)

4 connected shortline

All riders are connected to each other with grip connection and are riding on the same axis parallel to the short side of the riding-area. The distance between rider 1 and 2 has to be identical to the distance between rider 2 and 3 and between rider 3 and 4. The way of stretch for all shortline figures will start 1 metre from the short side of the riding-area until 1 metre before the opposite border of the riding-area.

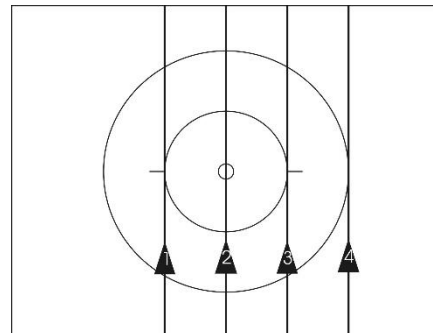

4161 a
4162 a
4163 a
4163 b
4164 a

4 connected shortline 2 connected single rings left

All riders are connected to each other with grip connection and are riding on the same axis parallel to the short side of the riding-area. The distance between rider 1 and 2 has to be identical to the distance between rider 2 and 3 and between rider 3 and 4. The way of stretch for all short line figures will start at 1 metre distance from the short side of the riding-area until 1 metre before the opposite border of the riding-area.

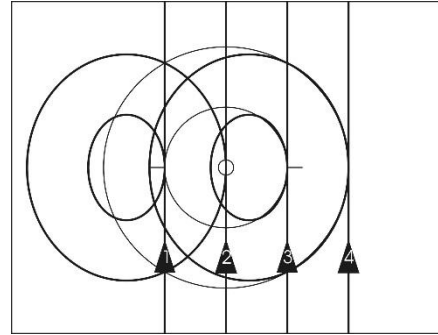

4161 b
4162 b
4163 c
4163 d
4164 b

During the figure the grip connection between rider 2 and rider 3 has to be released. The two groups of riders perform simultaneously a 2 connected single ring left with same size and uniform.

The shortline has to be performed 2 metres before and 2 metres after the single ring left.

2 connected single ring left (8.3.033)

4 connected shortline 2 connected single rings right

All riders are connected to each other with grip connection and are riding on the same axis parallel to the short side of the riding-area. The distance between rider 1 and 2 has to be identical to the distance between rider 2 and 3 and between rider 3 and 4.

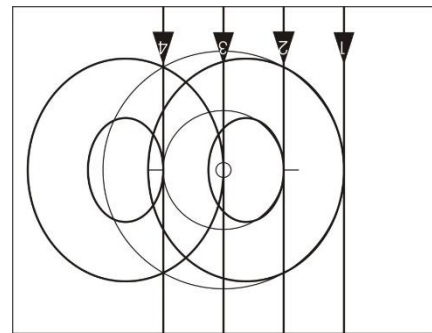

4161 c
4162 c

During the figure the grip connection between rider 2 and rider 3 has to be released. The two groups of riders perform simultaneously a 2 connected single ring right with same size and uniform.

The shortline has to be performed 2 metres before and 2 metres after the single ring left.

The way of stretch for all shortline figures will start 1 metre from the short side of the riding-area until 1 metre before the opposite border of the riding-area.

2 connected single ring right (8.3.034)

4 connected shortline 4 single rings left

All riders are connected to each other with grip connection and are riding on the same axis parallel to the short side of the riding-area. The distance between rider 1 and 2 has to be identical to the distance between rider 2 and 3 and between rider 3 and 4. During the figure, the grip connections have to be released simultaneously and in motion. Each rider performs a single ring left simultaneously and uniform.

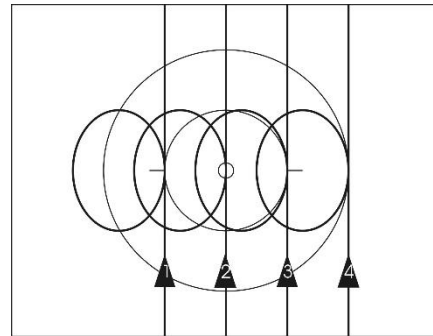

4161 d
4162 d
4163 e
4163 f
4164 c

After the single rings left, the riders have to close the grip connections simultaneously and in motion.

The shortline has to be performed 2 metres before and 2 metres after the single ring left.

The way of stretch for all shortline figures will start 1 metre from the short side of the riding-area until 1 metre before the opposite border of the riding-area.

Single ring left (8.3.029)

4 connected shortline 2 connected single rings left 2 connected single rings right

All riders are connected to each other with grip connection and are riding on the same axis parallel to the short side of the riding-area. The distance between rider 1 and 2 has to be identical to the distance between rider 2 and 3 and between rider 3 and 4. During the figure, the grip connections have to be released simultaneously and in motion. Each rider performs simultaneously a same sized and uniform single ring. Rider 1 and 2 are performing a single ring left and rider 3 and 4 are performing a single ring right.

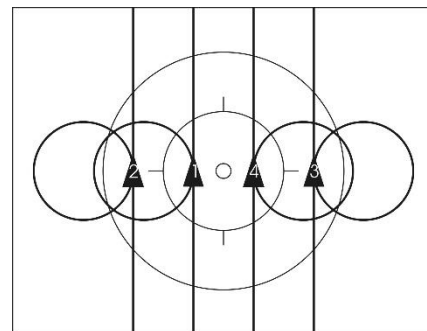

4164 d

After the single rings, the riders have to close the grip connections simultaneously and in motion. The shortline has to be performed 2 metres before and 2 metres after the single ring left.

The way of stretch for all shortline figures will start 1 metre from the short side of the riding-area until 1 metre before the opposite border of the riding-area.

Single ring left (8.3.029)

Single ring right (8.3.030)

4 next to each other shortline half counter single ring

All riders are riding next to each other without grip connection on an axis which runs parallel to the long side of the riding-area. The distance between rider 1 and 2 must be identical to the distance between rider 2 and 3 and to the distance between rider 3 and 4. All riders perform a half counter single ring.

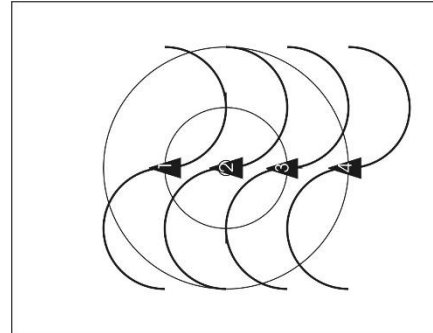

4161 e
4164 e

Half counter single ring (8.3.031)

4 next to each other short line counter single ring

All riders are riding next to each other without grip connection on an axis which runs parallel to the long side of the riding-area. The distance between rider 1 and 2 must be identical to the distance between rider 2 and 3 and to the distance between rider 3 and 4. All riders perform a counter single ring.

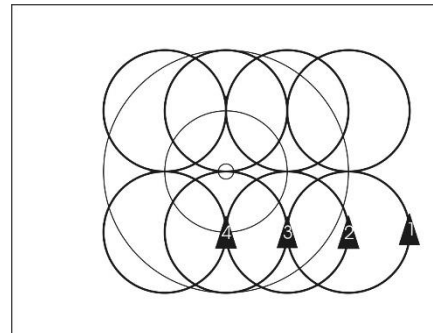

4161 f
4164 f

Counter single ring (8.3.032)

Surrounding 3 around 1

All riders are riding next to each other and are connected by hand-in-hand-grip-connection.

The inside rider is standing on a spot (without pedalling), while the other three riders are riding next to each other, on one line, a complete circle around the inside rider. The distance between rider 2 and 3 has to be identical to the distance between riders 3 and 4.

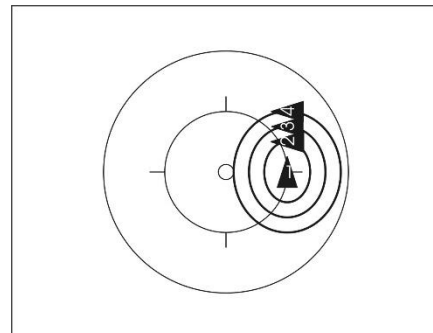

4171 a
4172 a
4173 a
4173 b
4174 a

The figure ends after a complete circle around the surrounded rider.

Coach half circle

All riders are riding around the 4-metre-circle.

Rider 1 grabs with the right hand to the left bicycle handlebar-grip of rider 2.

Rider 2 grabs with his left hand backwards to the right shoulder of rider 3.

Rider 3 grabs with the left hand, to the right shoulder of rider 4.

Rider 4 grabs with the right hand to the left shoulder of rider 1.

The figure ends when the 4-metre-circle is rounded half at the outside of the 4-metre-circle.

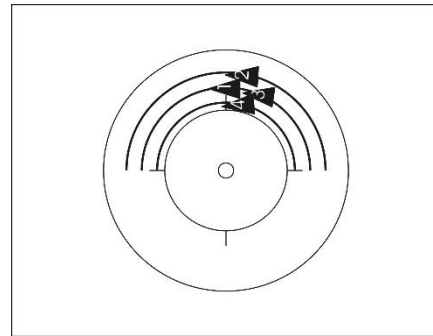

4181 a

Coach circle

All riders are riding around the 4-metre-circle.

Rider 1 grabs with the right hand to the left bicycle handlebar-grip of rider 2.

Rider 2 grabs with his left hand backwards to the right shoulder of rider 3.

Rider 3 grabs with the left hand, to the right shoulder of rider 4.

Rider 4 grabs with the right hand to the left shoulder of rider 1.

The figure ends when the 4-metre-circle is rounded completely at the outside of the 4-metre-circle.

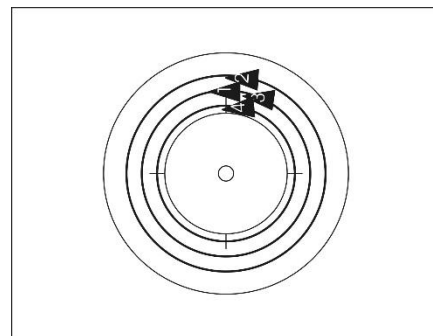

4181 b

Coach half circle raiser

All riders are riding around the 4-metre-circle.

Rider 1 grabs with his right hand to the **right left** hand of rider 2.

Rider 2 grabs with his left hand to the right hand of rider 3.

Rider 3 grabs with his left hand to the right hand of rider 4.

Rider 4 grabs with the left hand to the left hand of rider 1.

The figure ends when the 4-metre-circle is rounded half at the outside of the 4-metre-circle.

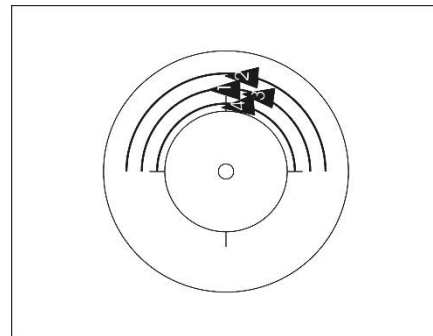

4182 a

Coach circle raiser

All riders are riding around the 4-metre-circle.

Rider 1 grabs with his right hand to the **right left** hand of rider 2.

Rider 2 grabs with his left hand to the right hand of rider 3.

Rider 3 grabs with his left hand to the right hand of rider 4.

Rider 4 grabs with his left hand to the left hand of rider 1.

The figure ends when the 4-metre-circle is rounded completely at the outside of the 4-metre-circle.

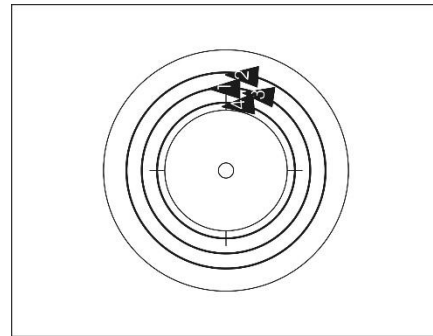

4182 b

Snake half circle

All riders are riding around the 4-metre-circle in left-right position.

Rider 1 grabs with his right hand to the bicycle handlebar of rider 2.

Rider 2 grabs with his left hand to the bicycle handlebar of rider 3.

Rider 3 grabs with his right hand to the bicycle handlebar of rider 4.

Rider 4 grabs with both hands his own bicycle handlebar.

The figure ends when the 4-metre-circle is rounded half at the outside of the 4-metre-circle.

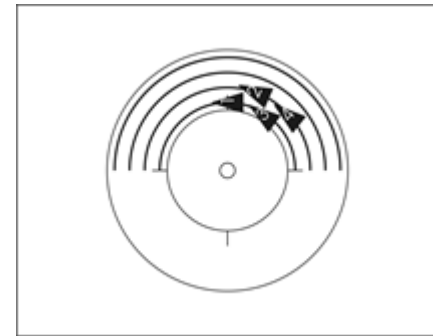

4183 a

Snake circle

All riders are riding around the 4-metre-circle in left-right position.

Rider 1 grabs with his right hand to the bicycle handlebar of rider 2.

Rider 2 grabs with his left hand to the bicycle handlebar of rider 3.

Rider 3 grabs with his right hand to the bicycle handlebar of rider 4.

Rider 4 grabs with both hands his own bicycle handlebar.

The figure ends when the 4-metre-circle is rounded completely at the outside of the 4-metre-circle.

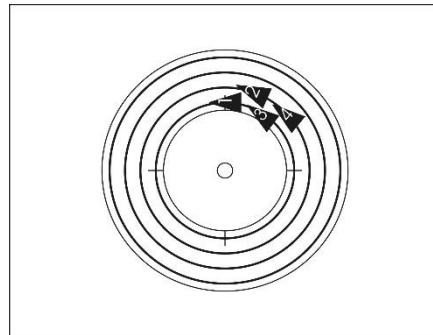

4183 b

Chain half circle

All riders are riding around the 4-metre-circle in left-right position.

Rider 1 grabs with both hands with his own bicycle handlebar.

Rider 2 grabs with his left hand the right shoulder of rider 1.

Rider 3 grabs with his right hand the left shoulder of rider 2.

Rider 4 grabs with his left hand the right shoulder of athlete 3.

The figure ends when the 4-metre-circle is rounded half at the outside of the 4-metre-circle.

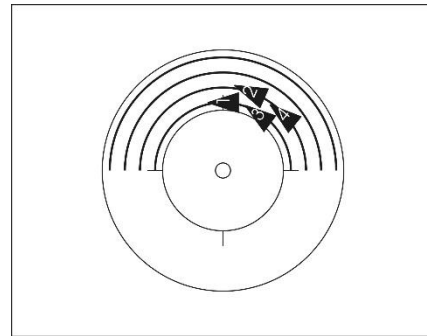

4191 a

Chain circle

All riders are riding around the 4-metre-circle in left-right position.

Rider 1 grabs with both hands his own bicycle handlebar.

Rider 2 grabs with his left hand the right shoulder of rider 1.

Rider 3 grabs with his right hand the left shoulder of rider 2.

Rider 4 grabs with his left hand the right shoulder of athlete 3.

The figure ends when the 4-metre-circle is rounded completely at the outside of the 4-metre-circle.

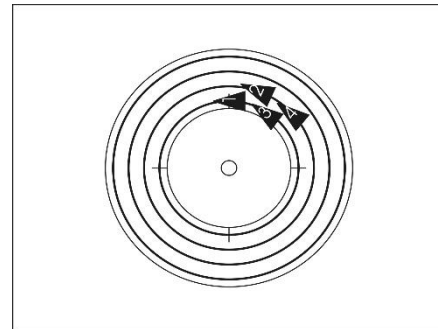

4191 b

Chain circle raiser

All riders are riding around the 4-metre-circle in left-right position.

Rider 1 grabs with his right hand the right hand of rider 2. Rider 2 grabs with his left hand the left hand of rider 3. Rider 3 grabs with his right hand the right hand of rider 4. The hands which are not connected have be stretched sideways.

The figure chain raiser half circle ends, when the 4-metre-circle is rounded half at the outside of the 4-metre-circle.

The figure chain raiser circle ends when the 4-metre-circle is rounded completely at the outside of the 4-metre-circle.

4192

Saddlegrip half circle

All riders are riding around the 4-metre-circle shifted in steps to the back.

Rider 1 grabs with both hands his own bicycle handlebar

Rider 2 grabs with his left hand the saddle of rider 1.

Rider 3 is grabs with his left hand the saddle of rider 2.

Rider 4 is grabs with his left hand the saddle of rider 3.

The figure ends when the 4-metre-circle is rounded half at the outside of the 4-metre-circle.

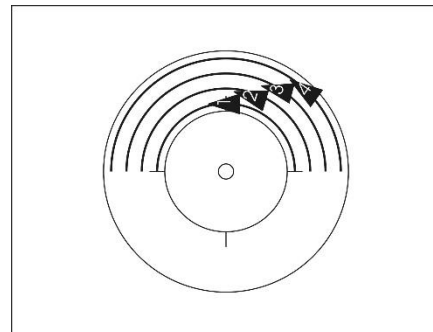

4196 a

Saddlegrip Circle

All riders are riding around the 4-metre-circle shifted in steps to the back.

Rider 1 grabs with both hands his own bicycle handlebar

Rider 2 grabs with his left hand the saddle of rider 1.

Rider 3 is grabs with his left hand the saddle of rider 2.

Rider 4 is grabs with his left hand the saddle of rider 3.

The figure ends when the 4-metre-circle is rounded completely at the outside of the 4-metre-circle.

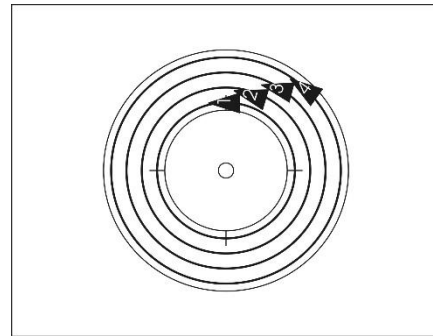

4196 b

Saddlegrip pass through

Startposition is saddlegrip.

Rider 1 and 2 are connected by their left hands.

Rider 2, 3, and 4 are still connected to each other by saddlegrip and will pass rider 1 at the inside.

In this way the riders execute a pass through.

The figure ends at the moment that all riders are performing a saddlegrip or a saddlegrip-ring.

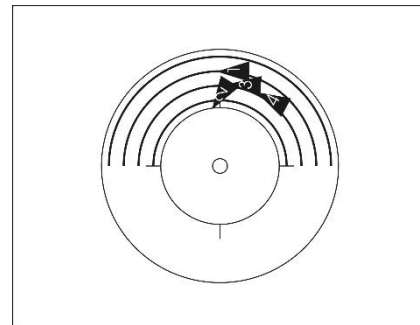

4197 a

Saddlegrip

All riders are riding around the 4-metre-circle shifted in steps to the back.

Rider 1 is connected with both hands to his own bicycle handlebar Rider 2 grabs with his left hand the saddle of rider 1. Rider 3 grabs with his left hand the saddle of rider 2. Rider 4 grabs with his left hand the saddle of rider 3.

Saddlegrip-ring

All riders are riding behind each other around the centre of the riding-area.

The distances have to be identical. Rider 1 grabs with his left hand the saddle of rider 4. Rider 2 grabs with his left hand the saddle of rider 1.

Rider 3 grabs with his left hand the saddle of rider 2. Rider 4 grabs with his left hand the saddle of rider 3.

Saddlegrip-ring

All riders are riding behind each other around the centre of the riding-area. The distances have to be identical.

Rider 1 grabs with his left hand the saddle of rider 4.

Rider 2 grabs with his left hand the saddle of rider 1.

Rider 3 grabs with his left hand the saddle of rider 2.

Rider 4 grabs with his left hand the saddle of rider 3.

The figure ends after the way of stretch of a complete circle around the centre of the riding-area.

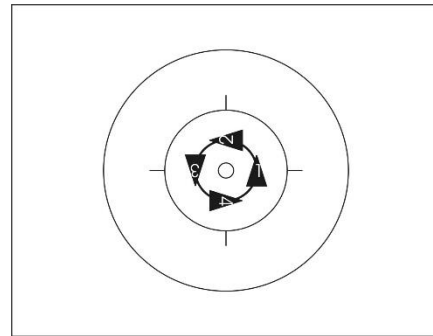

4198 a
4199 a
4199 b
4199 c

Saddlegrip-ring 4 single rings right

All riders are riding behind each other around the centre of the riding-area. The distances have to be identical.

Rider 1 grabs with his left hand the saddle of rider 4.

Rider 2 grabs with his left hand the saddle of rider 1.

Rider 3 grabs with his left hand the saddle of rider 2.

Rider 4 grabs with his left hand the saddle of rider 3.

During the figure the grip connections have to be released simultaneously and in motion. Each rider performs simultaneously a same sized and uniform single ring right.

After the single rings the riders have to close the grip connection simultaneously and in motion. The saddlegrip-ring has to be performed 2 metres before and 2 metres after the single rings right.

The figure ends after the way of stretch of a complete circle around the centre of the riding-area.

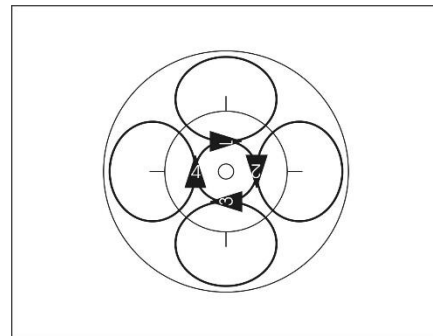

4198 b

Single ring right (8.3.030)

2 connected Wingmill

Two riders of each group are connected by grip-connection and are riding side by side. The distances between rider 1 and 2 has to be identical to the distances between rider 3 and 4. Both groups are riding with the same distances between each other on the same axis, while riding around the centre of the riding-area. The inside riders of the groups are connected to each other by their left hands, above the centre of the riding-area.

The figure ends after the way of stretch of a complete surrounding around the centre of the riding-area.

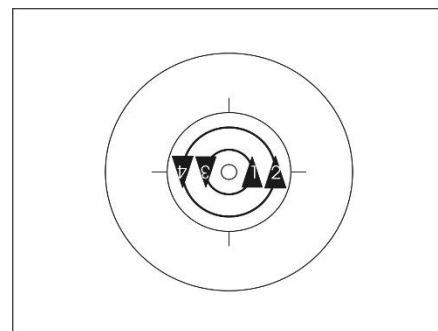

4211 a
4212 a
4212 d
4212 e
4213 a
4213 b
4213 c
4213 d
4213 e
4213 f
4214 a
4214 b
4214 c

2 connected wingmill half surrounding 2 connected single rings right

Two riders of each group are connected by grip-connection and are riding side by side. The distance between rider 1 and 2 has to be identical to the distance between riders 3 and 4. Both groups are riding with same distances between each other on the same axis, while riding around the centre of the riding-area. The inside riders of the groups are connected to each other by their left hands, above the centre of the riding-area.

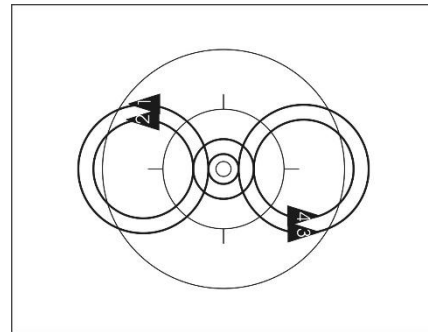

4211 b
4212 b
4214 e

During the figure the grip connection between the inside riding riders has to be released. The two groups of riders perform a 2 connected single ring right simultaneously and uniform. After the single rings the riders have to close the grip connection simultaneously and in motion.

The half surrounding has to be performed 2 metres before of and 2 metres after the single rings.

The figure ends after the way of stretch of a half surrounding around the centre of the riding-area.

2 connected single ring right (8.3.034)

2 connected wingmill 2 connected single rings right

Two riders of each group are connected by grip-connection and are riding side by side. The distance between rider 1 and 2 has to be identical to the distance between riders 3 and 4. Both groups are riding with same distances between each other on the same axis, while riding around the centre of the riding-area. The inside riders of the groups are connected to each other by their left hands, above the centre of the riding-area.

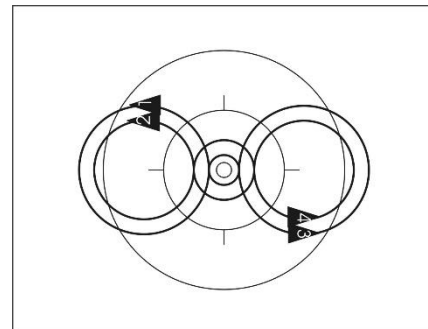

4211 c
4212 c
4214 f

During the figure the grip connection between the inside riding riders has to be released. The two groups of riders perform a 2 connected single ring right simultaneously and uniform.

After the single rings the riders have to close the grip connection simultaneously and in motion.

The surrounding has to be performed 2 metres before of and 2 metres after the single rings.

The figure ends after the way of stretch of a complete surrounding around the centre of the riding-area.

2 connected single ring right (8.3.034)

2 connected wingmill half surrounding 4 single rings right

Two riders of each group are connected by grip connection and are riding side by side. The distance between rider 1 and 2 has to be identical to the distance between riders 3 and 4. Both groups are riding with same distances between each other on the same axis, while riding around the centre of the riding-area.

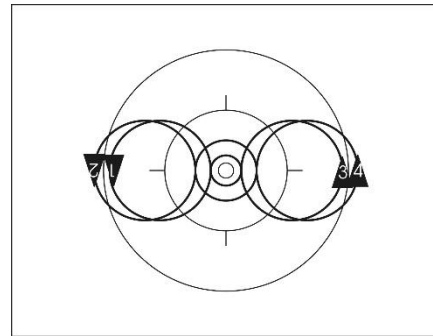

4211 d
4214 g
4214 h
4214 i

The inside riders of the groups are connected to each other by their left hands, above the centre of the riding-area.

During the figure the grip connections have to be released simultaneously and in motion. Each rider performs a single ring right simultaneously and uniform. After the single rings the riders have to close the grip connection simultaneously and in motion.

The half surrounding has to be performed 2 metres before of and 2 metres after the single rings.

The figure ends after the way of stretch of a half surrounding around the centre of the riding-area.

Single ring right (8.3.030)

2 connected wingmill 4 single rings right

Two riders of each group are connected by grip connection and are riding side by side. The distance between rider 1 and 2 has to be identical to the distance between riders 3 and 4. Both groups are riding with same distances between each other on the same axis, while riding around the centre of the riding-area.

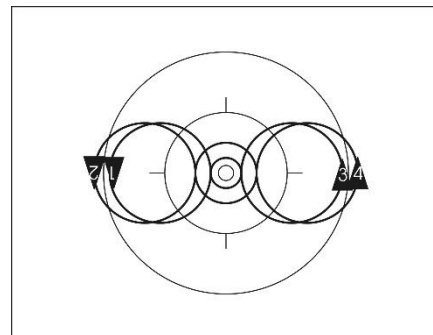

4211 e
4214 j
4214 k
4214 l

The inside riders of the groups are connected to each other by their left hands, above the centre of the riding-area.

During the figure the grip connections have to be released simultaneously and in motion. Each rider performs a single ring right simultaneously and uniform. After the single rings the riders have to close the grip connection simultaneously and in motion.

The wingmill has to be performed 2 metres before of and 2 metres after the single rings.

The figure ends after the way of stretch of a complete surrounding around the centre of the riding-area.

Single ring right (8.3.030)

2 connected wingmill mill with 2 single rings right

Two riders of each group are connected by grip connection and are riding side by side. The distance between rider 1 and 2 has to be identical to the distance between riders 3 and 4. Both groups are riding with same distances between each other on the same axis, while riding around the centre of the riding-area.

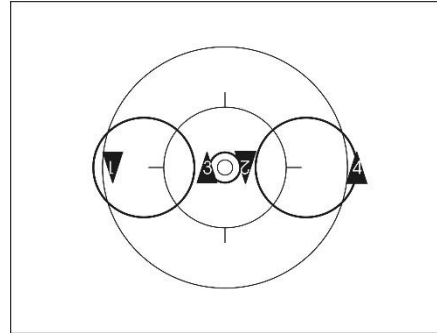

4214 d

The inside riders of the groups are connected to each other by their left hands, above the centre of the riding-area.

During the figure the 2 outside riding riders have to release their grip connections simultaneously and in motion and perform a same sized and uniform single ring right. During the single rings right the 2 inside riding riders have to surround the centre of the riding-area at least once completely. After the single rings right the wingmill has to be closed simultaneously and in motion. The wingmill has to be performed 2 metres before of and 2 metres after the single rings.

Single ring right (8.3.030)

2 connected wingring

Two riders of each group are connected by grip-connection and are riding side by side. The distance between rider 1 and 2 has to be identical to the distance between riders 3 and 4. Both groups are riding with same distances between each other on the same axis, while riding around the centre of the riding-area.

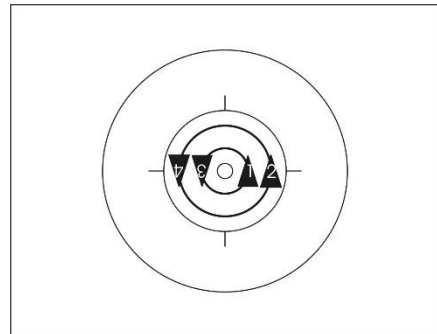

4223 a
4223 b
4223 c
4223 d
4223 e
4223 f
4224 a
4224 b
4224 c

The inside riders of the groups are connected with their right hand to the left hand of their partner with hand-in-hand grip connection.

The figure begins, when all grip connections are closed.

The figure ends after the way of stretch of a complete surrounding around the centre of the riding-area.

2 connected wingmill mill with 2 following each other circle

Two riders of each group are connected by grip connection and are riding side by side. The distance between rider 1 and 2 has to be identical to the distance between riders 3 and 4. Both groups are riding with same distances between each other on the same axis, while riding around the centre of the riding-area.

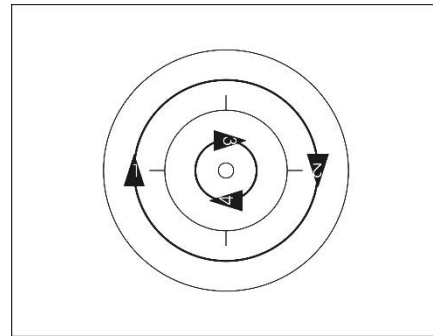

4230 a
4231 a
4232 a
4232 b
4233 a

The inside riders of the groups are connected to each other by their left hands, above the centre of the riding-area.

During the figure the 2 outside riding riders have to release their grip connections simultaneously and in motion and ride with same distances between each other and at same distances to the 4-metre-circle, once completely around the 4-metre-circle. During the outside riders are riding around the 4-metre-circle the 2 inside riding riders have to surround the centre of the riding-area at least once completely.

After the circle is finished, the wingmill has to be closed simultaneously and in motion.

The figure ends, after all grip connections are closed.

2 connected wingring insidering with 2 following each other circle

Two riders of each group are connected by grip connection and are riding side by side. The distance between rider 1 and 2 has to be identical to the distance between riders 3 and 4. Both groups are riding with same distances between each other on the same axis, while riding around the centre of the riding-area.

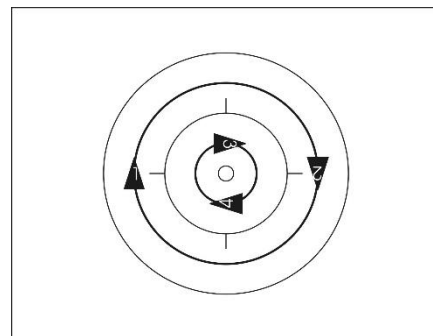

4232 c
4232 d
4233 b

The inside riders of the groups are connected with their right hand to the left hand of their partner with hand-in-hand grip connection.

During the figure the 2 outside riding riders have to release their grip connections simultaneously and in motion and ride with same distances between each other and at same distances to the 4-metre-circle, once completely around the 4-metre-circle. The 2 inside riding riders have to surround in the meantime the centre of the riding-area at least once completely.

After the circle is finished, the wingring has to be closed simultaneously and in motion.

The figure ends, after all grip connections are closed.

2 connected wingmill mill with 3 spinnings

Two riders of each group are connected by grip connection and are riding side by side. The distance between rider 1 and 2 has to be identical to the distance between riders 3 and 4. Both groups are riding with same distances between each other on the same axis, while riding around the centre of the riding-area.

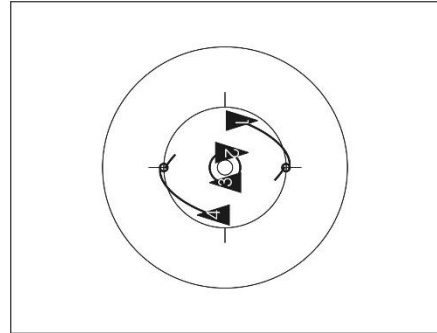

4233 c

The inside riders of the groups are connected to each other by their left hands, above the centre of the riding-area.

During the figure the 2 outside riding riders have to release their gripconnections simultaneously and in motion and perform 3 spinnings simultaneous one the same axis, which goes though the centre of the riding-area. After the spinnings the grip connections have to be closed simultaneously and in motion. The 2 inside riding riders have to surround in the meantime the centre of the riding-area at least once completely. The wingmill has to be performed 2 metres before and 2 metres after the spinnings.

Spinnings (8.3.037)

Mill

All riders are following each other with same distances to each other while riding around the centre of the riding-area. All riders have the same distance to the centre of the riding-area. During the figure all riders are connected with their left hands, above the centre of the riding-area. The figure has to be performed within the 4-metre-circle. The figure ends not before a complete surrounding around the centre of the riding-area is performed.

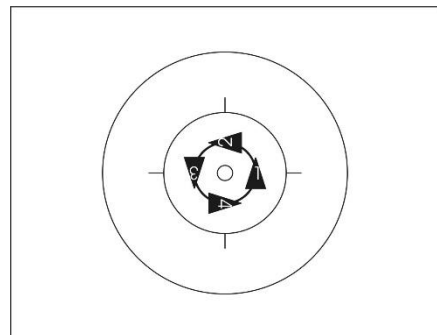

- 4241 a
- 4242 a
- 4242 b
- 4242 c
- 4243 a
- 4243 b
- 4243 c
- 4243 d
- 4243 e
- 4243 f
- 4244 a
- 4244 b
- 4244 c

Mill 4 single rings right

All riders are following each other with same distances to each other while riding around the centre of the riding-area. All riders have the same distance to the centre of the riding area. During the figure all riders are connected by their left hands, above the centre of the riding-area. The figure has to be performed within the 4-metre-circle.

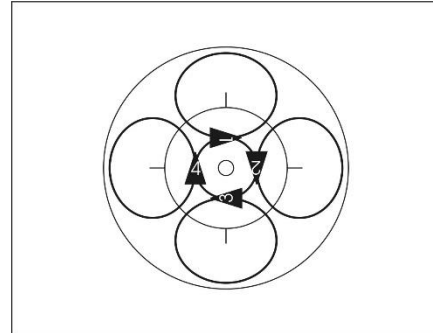

4241 b
4244 d
4244 e

During the figure the grip connections have to be released simultaneously and in motion. Each rider performs simultaneously a same sized and uniform single ring right. After the single rings the riders have to close the grip connection simultaneously and in motion.

The mill has to be performed 2 metres before of and 2 metres after the single ring right.

The figure ends not before a complete surrounding around the centre of the riding-area is performed.

Single ring right (8.3.030)

Insidering around 1

Three riders are riding with same distances between each other around the centre of the riding-area. Each of the three riders grabs with his right hand the left hand of the rider in front of him. The fourth rider is connected (kind of connection is free) to only one of the three riders and turns around his own longitudinal axis without pedaling. The figure ends after

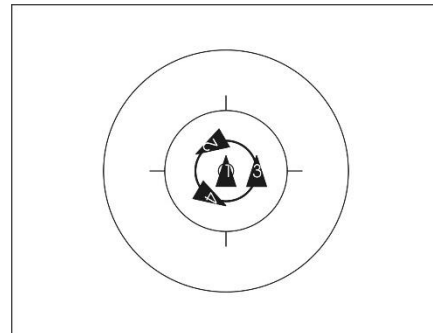

4251 a
4251 b
4251 c
4251 d
4251 e
4252 a
4252 b
4252 c

executing the way of stretch of a complete circle around the centre of the riding-area. The figure has to be performed within the 4-metre-circle.

Insidering

All riders are riding at the same distance, following each other, around the centre of the riding-area. Each rider grabs with the right hand the left hand of the rider in front of him. The figure has to be performed within the 4-metre-circle. The figure ends after executing the way of stretch of a complete circle around the centre of the riding-area.

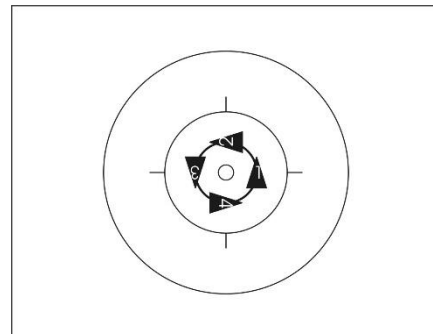

4258 a
4258 b
4258 c
4258 d
4258 e
4259 a
4259 b
4259 c

Ring with opposite grips

All riders are riding at the same distance, following each other, around the centre of the riding-area. Rider 1 and rider 3 grab with their left hands into the left hands of the riders in front of them. Rider 2 and rider 4 grab with their right hands into the right hands of the riders in front of them. The figure ends after executing the way of stretch of a complete circle around the centre of the riding-area.

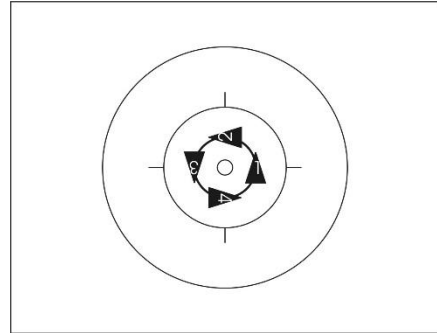

4267 a
4267 c
4267 d
4267 e
4267 f
4268 a
4268 c
4268 d

Ring with opposite grips HS followed by insidering HS

Starting position is the ring with opposite grips. After performing the way of stretch of a half circle all riders have to release and to close simultaneously and in motion their grip connection into the position inside ring. The figure ends after the way of stretch of a half circle in the position inside ring.

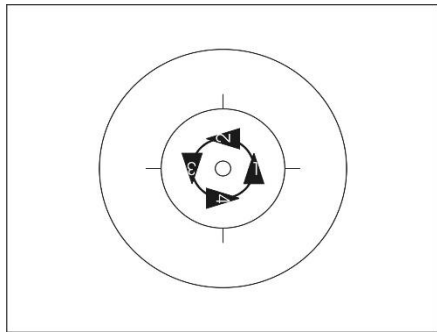

4267 b
4268 b

Ring with opposite grips

All riders are riding with same distance, following each other, around the centre of the riding-area. Rider 1 and rider 3 grab with their left hand the left hand of the riders in front of them. Rider 2 and rider 4 grab with their right hands the right hand of the riders in front of them. The figure has to be performed within the 4-metre-circle.

Insidering

All riders are riding with same distance, following each other, around the centre of the riding-area. Each rider grabs with the right hand the left hand of the rider which is riding in front of him. The figure has to be performed within the 4-metre-circle.

Outsidering

All riders are riding with same distance, following each other, around the centre of the riding-area. Each rider grabs with his left hand the right hand of the rider in front of him. The figure has to be performed within the 4-metre-circle. The figure ends after executing the way of stretch of a complete circle around the centre of the riding-area.

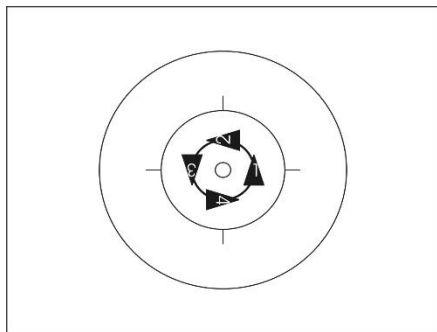

4272 a
4272 b
4272 c
4272 d
4272 e
4273 a
4273 b
4273 c

Half door

Two riders are standing on the longitudinal or transverse axis of the riding-area. They are connected by hand-in-hand grip connection, above the middle of the riding-area. The other arms of the connected riders are stretched sideways, horizontally. So they are building a door. The other two riders are riding with same distances following each other through the door each once. One of the two riders which are building the door, will be surrounded.

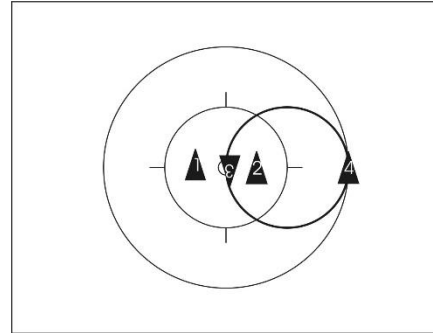

4280 a
4281 a
4282 a
4282 c
4283 a

The figure starts 2 metres before the first rider is riding through the door and ends 2 metres after the second rider has passed the door. The door has to stand still at least until the riders which were passing the door, have finished their total way of stretch.

Door

Two riders are standing on the longitudinal or transverse axis of the riding-area. They are connected by hand-in-hand grip connection, above the middle of the riding-area. The other arms of the connected riders are stretched sideways, horizontally. So they are building a door. The other two riders are riding at same distances following each other through the door each twice. One of the two riders which are building the door, will be surrounded.

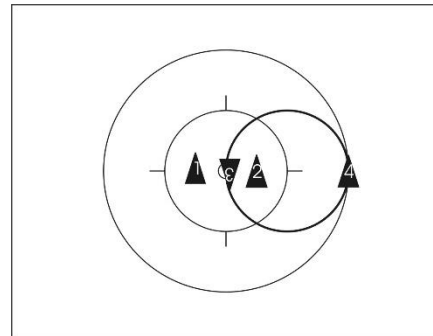

4280 b
4281 b
4282 b
4282 d
4283 b

The figure starts 2 metres before the first rider is riding through the door and ends 2 metres after the second rider has passed the door. The door has to stand still at least until the riders which were passing the door, have finished their total way of stretch.

Half opposite direction door

Two riders are standing on the longitudinal or transverse axis of the riding-area. They are connected by hand-in-hand grip connection, which is situated above the middle of the riding-area. The other arms of the connected riders are stretched sideways, horizontally. So they are building a door.

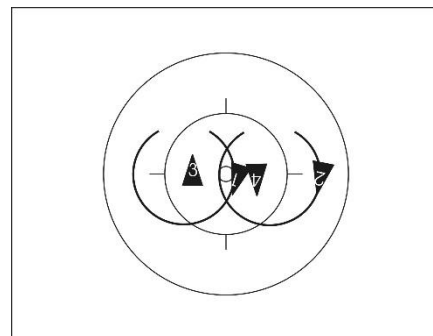

4280 c
4281 c
4285 a
4285 c
4286 a

The other two riders are riding on the same, imaginary axis which runs parallel to the short or long side of the riding-area. Each of these riders will ride through the door once. One of the two riders which are building the door, will be surrounded.

The figure starts 2 metres before the first rider is riding through the door and ends 2 metres after the second rider has passed the door. The door has to stand still at least until the riders which were passing the door, have finished their total way of stretch.

Opposite direction door

Two riders are standing on the longitudinal or transverse axis of the riding-area. They are connected by hand-in-hand grip connection, above the middle of the riding-area. The other arms of the connected riders are stretched sideways, horizontally. So they are building a door. The other two riders are riding on the same, imaginary, axis which runs parallel to the short or long side of the riding-area. Each of these riders will have to ride through the door twice. One of the two riders which are building the door, will be surrounded.

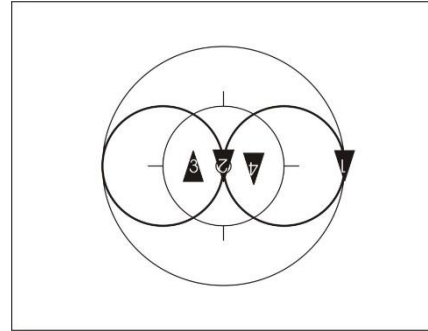

4280 d
4281 d
4285 b
4285 d
4286 b

The figure starts 2 metres before the first rider is riding through the door and ends 2 metres after the second rider has passed the door. The door has to stand still at least until the riders which were passing the door, have finished their total way of stretch.

Opposite direction door simultaneously

Two riders are standing on the longitudinal or transverse axis of the riding-area. They are connected by hand-in-hand grip connection, which is located above the middle of the riding-area. The other arms of the connected riders are stretched sideways, horizontally. So they are building a door. The other two riders will ride each twice, simultaneous, through the door, while surrounding one of the riders building a door.

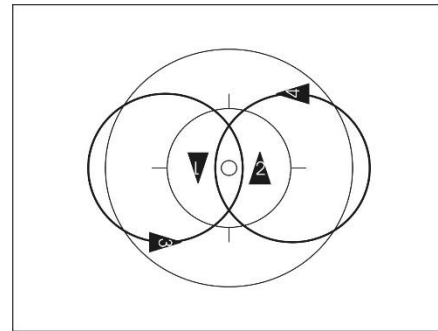

4280 e
4281 e
4284 a
4287 a
4287 b

The figure starts 2 metres before the first rider is riding through the door and ends 2 metres after the second rider has passed the door. The door has to stand still at least until the riders which were passing the door, have finished their total way of stretch.

Mill with half opposite direction door

4288 a

Two riders are connected with their left hands and are performing a mill at the middle of the riding-area. Their right arms are stretched sideways, horizontally.

The two other riders are riding each once through the door the mill is building. The two riders are shifted a half way of their stretch each on one half of the riding-area. The riding-area will be divided of the longitudinal and transverse axis. For the door passing the own half of the riding-area may be left.

The figure starts 2 metres before the first rider is riding through the door and ends 2 metres after the second rider has passed the door. The mill has to ride at least until the riders which were passing the door, have finished their total way of stretch.

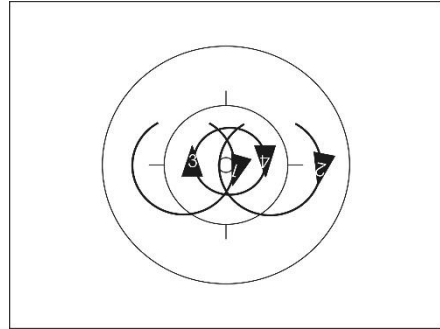

Mill with opposite direction door

4288 b

Two riders are connected with their left hands and are performing a mill at the middle of the riding-area. Their right arms are stretched sideways, horizontally.

The two other riders are riding each twice through the door the mill is building. The two riders are shifted a half way of their stretch each on one half of the riding-area. The riding-area will be divided of the longitudinal and transverse axis. For the door passing the own half of the riding-area may be left.

The figure starts 2 metres before the first rider is riding through the door and ends 2 metres after the second rider has passed the door. The mill has to ride at least until the riders which were passing the door, have finished their total way of stretch.

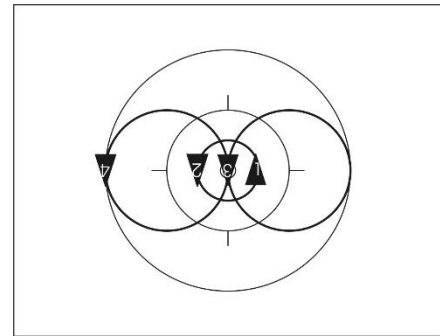

Mill with opposite direction door simultaneously

4284 b

Two riders are connected with their left hands and are performing a mill at the middle of the riding-area. Their right arms are stretched sideways, horizontally.

The two other riders will pass, each twice, simultaneously the door. Each of the passing riders is performing a circle with same size and same speed.

The way of stretch for the passing riders starts 2 metres before the first rider is passing the door and ends 2 metres after the last rider has passed the door. The mill has to ride until the mentioned way of stretch of the passing riders is completed.

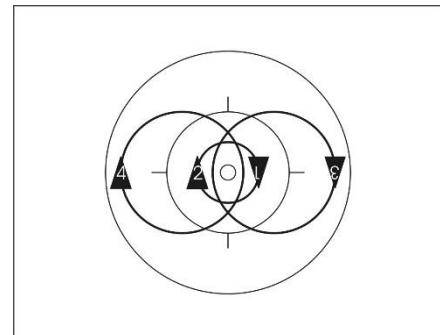

Double door

Three riders are standing on the longitudinal or transverse axis of the riding-area and are connected by hand-in-hand grip connection performing a double door. The central rider is standing in the middle of the riding-area. The not connected arms of the riders building a double door, are stretched sideways, horizontally. The distance between rider 2 and 3 and the distance between rider 3 and 4 has to be identical. Rider 1 has to ride through each of the two doors twice. The way of stretch for the passing rider 4 starts 2 metres before the first passing and ends 2 metres after the last passing of the door. The double door has to stand still until the mentioned way of stretch of the passing rider is completed.

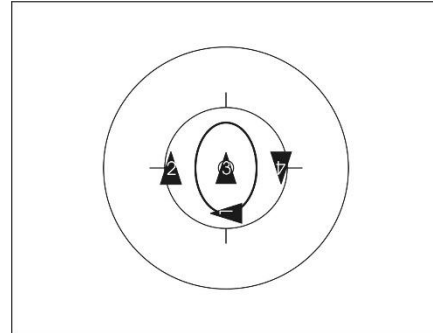

4291 a
4292 a
4293 a

Snake double door

Three riders are standing on the longitudinal or transverse axis of the riding-area and are connected by hand-in-hand grip connection building a double door. The central rider is standing at the middle of the riding-area. The not connected arms of the standing riders are stretched sideways, horizontally. The distance between the standing riders has to be identical. Rider 4 is required to pass alternately each of the two doors twice, changing the riding-direction after each pass through. The way of stretch for the passing rider 4 starts latest 2 metres before the first passing and ends earliest 2 metres after the last passing of the door. The riders which are performing the door have to stand still at least the passing rider has reached his starting position again.

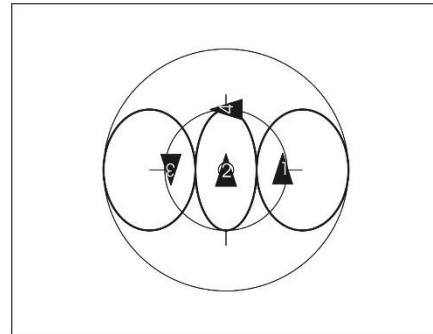

4292 b
4294 a

Turbine raiser snake double door raiser bw. frh. ~~opposite-direction~~

4294b

Three riders are next to each other on a straight line and are connected by hand-in-hand grip-connection. The not connected arms of these riders are stretched sideways, horizontally. The position of the central rider is the middle of the riding-area and he is standing on this spot without pedalling. The two outside riders are riding forward, around the central rider and will turn the rider on the spot (middle of the riding-area); performing a turbine.

Rider 4 is required to pass ~~in opposite-direction~~ the both moving spaces, who are performing a turbine. He has to pass each of the two doors twice backward, changing the riding-direction after each pass through.

The way of stretch for the passing rider 4 starts latest 2 metres before the first passing and ends earliest 2 metres after the last passing of the door. The turbine is riding at least the passing rider has reached his starting position again.

Turbine double door

Three riders are next to each other on a straight line and are connected by hand-in-hand grip connection. The not connected arms of these riders are stretched sideways, horizontally. The position of the central rider is the middle of the riding-area and he is standing on this spot without pedalling. The two outside riders are riding forward, around the central rider and will turn the rider on the spot (middle of the riding-area); performing a turbine. Rider 4 is required to ride backwards, twice through each door, riding around the central rider. The way of stretch for the passing rider 4 starts 2 metres before the first passing and ends 2 metres after the last passing of the door. The riders which are performing the turbine have to ride until the passing rider has completed the mentioned way of stretch.

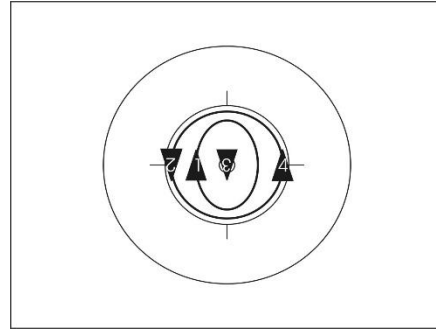

4293 b

Counter single ring door

Two riders are standing on the longitudinal or transverse axis of the riding-area. They are connected by hand-in-hand grip above the middle of the riding-area. The not connected arms are stretched sideways, horizontally. So the riders are building a door.

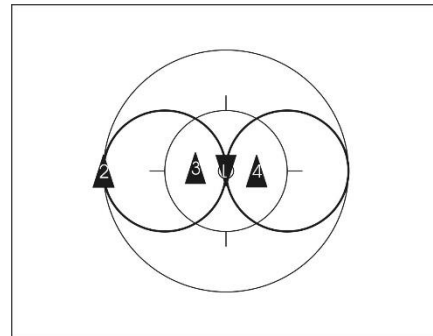

4296 a
4297 a

The two other riders will pass the door twice with same distances following each other performing a counter single ring same size and uniform. The way of stretch for the passing riders starts latest 2 metres before the first rider is passing the door and ends earliest 2 metres after the last rider has passed the door. The riders which are performing the door have to stand still at least the passing riders have reached their starting position again.

Counter single ring (8.3.032)

Opposite direction door Counter single rings simultaneous

Two riders are standing on the longitudinal or transverse axis of the riding-area. They are connected by hand-in-hand grip above the middle of the riding-area. The not connected arms are stretched, sideways, horizontally. So the riders are building a door.

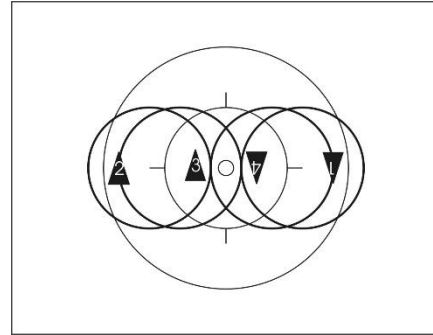

4281 f
4298 a

The two other riders will pass, each twice, simultaneously the door. Each of the passing riders is performing a counter single ring same size and uniform.

The passing riders will start their way of stretch while riding in the same direction each on the other half of the riding-area. The riding-area will be divided of the longitudinal and transverse axis.

The way of stretch for the passing riders starts latest 2 metres before the first rider is passing the door and ends earliest 2 metres after the last rider has passed the door.

The riders which are performing the door have to stand still at least the passing riders have reached their starting position again.

Counter single ring (8.3.032)

Mill with opposite direction door counter single ring simultaneous

Two riders are connected with their left hands and are performing a mill on middle of the riding-area. Their right arms are stretched sideways, horizontally.

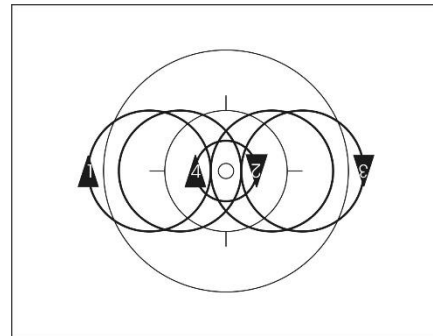

4298 b

The two other riders will pass, each twice, simultaneously the door. Each of the passing riders is performing a counter single ring same size and uniform.

The passing riders will start their way of stretch while riding in the same direction each on the other half of the riding-area. The riding-area will be divided of the longitudinal and transverse axis.

The way of stretch for the passing riders starts latest 2 metres before the first rider is passing the door and ends earliest 2 metres after the last rider has passed the door.

The mill has to ride at least the passing riders have reached their starting position again.

Counter single ring (8.3.032)

Half door ring

Two riders are standing on the longitudinal or transverse axis. They are connected to each other with their left hands through a hand-in-hand grip connection above the middle of the riding-area. The not connected arms of the riders are stretched sideways, horizontally. So the riders are building a door.

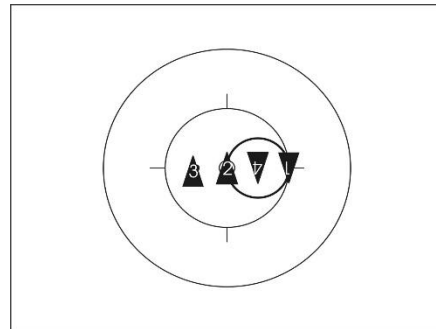

4307 a

The two other riders are riding at equal distances following each other each once through the door. Each of the two riders is connected with his right hand to the left hand of the the other rider.

The riders which are performing the door have to stand still until the passing riders have completed the mentioned way of stretch.

Door ring

Two riders are standing on the longitudinal or transverse axis. They are connected to each other with their left hands through a hand-in-hand grip connection above the middle of the riding-area. The not connected arms of the riders are stretched sideways, horizontally. So the riders are building a door.

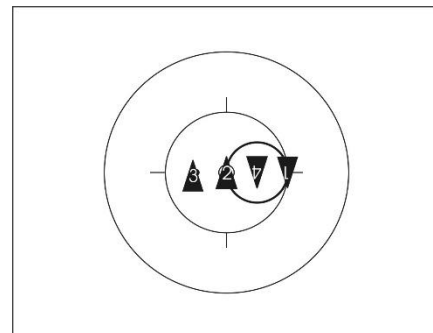

4307 b

The two other riders are riding at equal distances following each other each once through the door. Each of the two riders is connected with his right hand to the left hand of the the other rider.

The riders which are performing the door have to stand still until the passing riders have completed the mentioned way of stretch.

~~Door ring opposite direction~~ Compass raiser with ring raiser bw.

4307 c

Two riders are standing within the 4-metre-circle. They are connected to each other with their left hands. So the riders are **performing a compass. building a door**. The inside rider is standing on the middle of the riding-area, **and turns on a spot around his own longitudinal axis** without pedalling, ~~on a spot~~, while the partner is riding forward a complete circle around the inside rider. The not connected arms of the riders are stretched sideways, horizontally.

The two other riders are riding at equal distances following each other each once backward through the door. Each of the two riders is connected with his right hand to the left hand of the the other rider. So they are building a ring.

The figure ends after a complete surrounding of the door riding riders and after each ring riding rider at least passed the door twice.

Star inside 4 single rings

All riders are following each other, with the same distances between each other, around the 4-metre-circle. During the figure all riders perform a single ring left simultaneously and uniform. After finishing the single rings all riders will ride to the middle of the riding-area and perform all, simultaneously, a star by hand-in-hand connection. The bikes head tubes have to point to the middle of the riding-area. Each rider has to connect a hand-in-hand grip connection with two other riders.

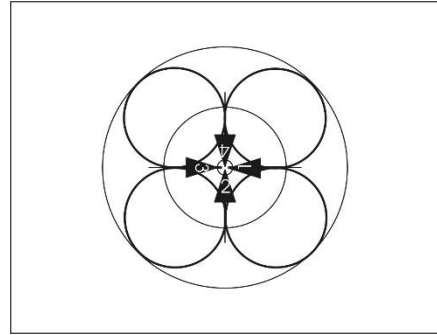

4316 b

Single ring left (8.3.029)

Star inside

All riders are standing, on the same distances between each other, without moving, around the middle of the riding-area. All are connected to each other by hand-in-hand grip-connection. The bikes head tubes have to point to the middle of the riding-area.

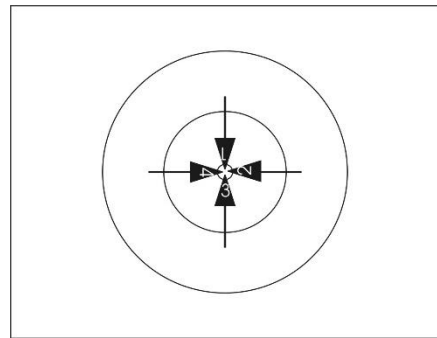

4316 a
4317 a
4317 b
4317 c

Star opposite direction

All riders are standing, at the same distances between each other, without moving, around the middle of the riding-area. All are connected to each other by hand-in-hand grip connection. The bikes head tubes of rider 1 and 3, and the rear wheels of rider 2 and 4 have to point to the middle of the riding-area.

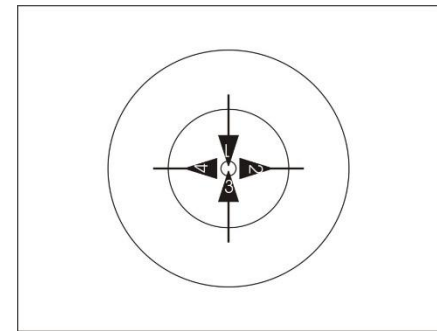

4327 a
4327 b
4327 c

Star outside

All riders are standing, at the same distances between each other, without moving, around the middle of the riding-area. All are connected to each other by hand-in-hand grip connection. The bikes rear wheels have to point to the middle of the riding-area.

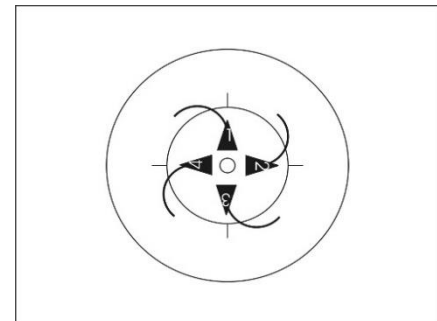

4326 a
4326 b
4328 a
4328 b

Star outside 4 single rings left

All riders are following each other, with same distances between each other, around the 4-metre-circle. During the figure all riders perform a single ring left simultaneously and uniform. After finishing the single rings all riders will ride to the middle of the riding-area and perform all, simultaneously, a star by hand-in-hand grip connection. The bikes rear wheels have to point to the middle of the riding-area.

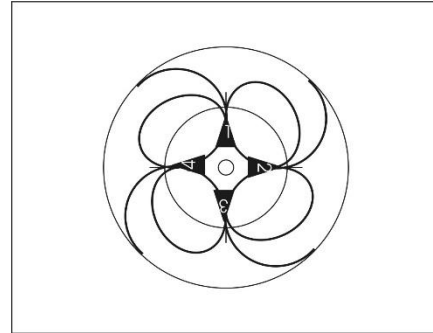

4326 c
4328 c

Single ring left (8.3.029)

Star inside ½ turn on the spot

Starting position is the star inside. From the position star inside all riders disconnect the grip connection and perform a half turn on the spot. After the turn all the riders connect with a grip connection to the end position star outside. The figure ends in the star outside.

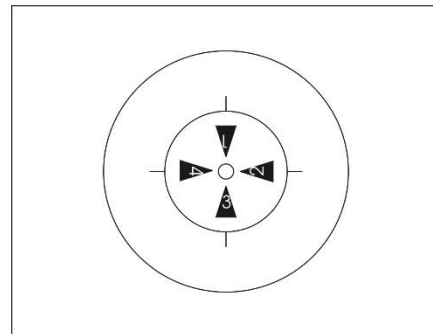

4331 a

Star inside (8.3.038)

½ turn on the spot (8.3.040)

Star outside (8.3.039)

Star inside 1 turn on the spot

Starting position is the star inside. From the position star inside all riders disconnect the grip connection and perform one turn on the spot. After the turn all the riders connect with a grip connection to the end position star inside. The figure ends in the star inside.

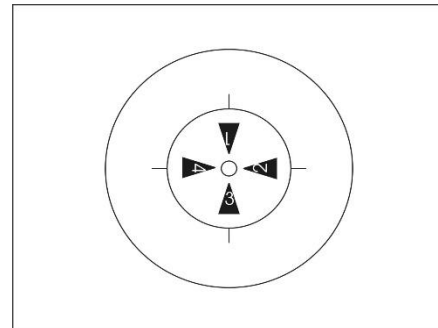

4331 b

Star inside (8.3.038)

1 turn on the spot (8.3.041)

2 connected raiser turn on the spot (T)

From a half turn on the tactical enlargement of the turn(s) on the spot is possible up to four half turns in maximum.

2 groups of each 2 riders. The riders of each group are connected by hand-in-hand grip connection. All riders are standing on an axis on the riding-area. The distance between rider 1 and 2

has to be identical as the distance between riders 3 and 4. During the figure the grip connections will be released simultaneously and all riders will perform, simultaneously, without pedalling, turn(s) on the spot. After the turns on the spot all riders connect simultaneously by hand-in-hand grip connection. When the grip connection are closed all riders have to stand still, without moving the bikes or their selves.

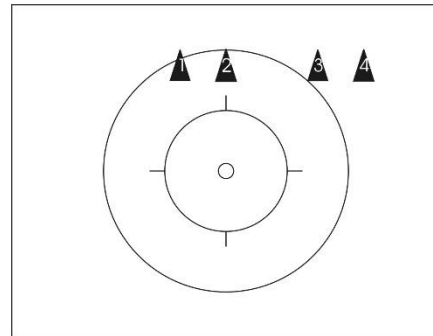

4341 a
4341 b
4341 c
4341 d

4 connected raiser turn on the spot (T)

From a half turn on the tactical enlargement of the turn(s) on the spot is possible up to four half turns in maximum.

All riders are connected to each other by hand-in-hand grip connection and are standing on axis on the riding-area. The distance between rider 1 and 2 has to be identical to the riders 2 and 3. But also between riders 3 and 4.

During the figure the grip connections will be released simultaneously and all riders will perform, simultaneously, without pedalling, turn(s) on the spot. After the turns on the spot all riders will connect simultaneously by hand-in-hand grip connection. When the grip connection are closed all riders have to stand still, without moving the bikes or their selves

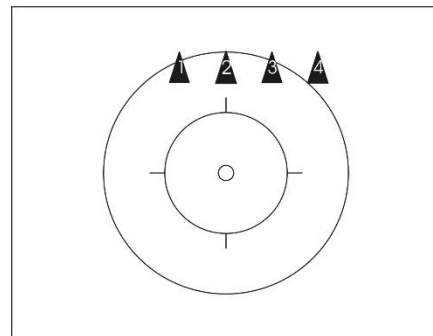

4341 e
4342 a
4342 b
4342 c
4342 d

(text modified on 01.01.16; 01.01.17)

Chapter X TABLE OF FIGURES ARTISTIC CYCLING TEAM 6

8.10.001 Artistic Cycling Team 6

The values after "T" can be reached by tactical extension of the belonging figure.

Figure No. / Name of figure	Point value
6001 a 6 f.e.o. HC.	0,4
6001 b 6 f.e.o. C.	0,6
6001 c 6 f.e.o. HC. 6 s.r.l.	1,0
6001 d 6 f.e.o. C. 6 s.r.l.	1,2
6001 e 6 f.e.o. HC. 3 s.r.l. 3 s.r.r.	1,0
6001 f 6 f.e.o. C. 3 s.r.l. 3 s.r.r.	1,2
6001 g 6 f.e.o. HC. 6 s.r.r.	0,9
6001 h 6 f.e.o. C. 6 s.r.r.	1,1
6002 a 6 f.e.o. HC bw.	1,8
6002 b 6 f.e.o. C. bw.	2,0
6002 c 6 f.e.o. HC. 6 s.r.l. bw.	3,0
6002 d 6 f.e.o. C. 6 s.r.l. bw.	3,2
6003 a 6 f.e.o. HC. raiser	2,3
6003 b 6 f.e.o. C. raiser	2,6
6003 c 6 f.e.o. HC. raiser frh.	2,6
6003 d 6 f.e.o. C. raiser frh.	2,9
6003 e 6 f.e.o. HC. 6 s.r.l. raiser	3,8
6003 f 6 f.e.o. C. 6 s.r.l. raiser	4,1
6003 g 6 f.e.o. HC. 6 s.r.l. raiser frh.	4,1
6003 h 6 f.e.o. C. 6 s.r.l. raiser frh.	4,4
6004 a 6 f.e.o. HC. raiser bw. frh.	5,3
6004 b 6 f.e.o. C. raiser bw. frh.	5,9
6004 c 6 f.e.o. HC. 6 s.r.l. raiser bw. frh.	6,9
6004 d 6 f.e.o. C. 6 s.r.l. raiser bw. frh.	7,5
6006 a 6 f.e.o. diagonal pull	0,9
6006 b 6 f.e.o. diagonal pull 3 s.r.l. 3 s.r.r.	1,5
6007 a 6 f.e.o. S	1,1
6007 b 6 f.e.o. 8	1,5
6007 c 6 f.e.o. 8 through	2,5
6008 a 6 f.e.o. S bw.	3,2
6008 b 6 f.e.o. 8 bw.	3,9
6008 c 6 f.e.o. 8 through bw.	5,2
6010 a 6 f.e.o. S raiser bw. frh.	7,6
6010 b 6 f.e.o. 8 raiser bw. frh.	8,3
6010 c 6 f.e.o. 8 through raiser bw. frh.	10,4
6011 a 6 f.e.o. longline	0,9
6011 b 6 f.e.o. longline 3 s.r.l. 3 s.r.r.	1,5

UCI CYCLING REGULATIONS

Figure No. / Name of figure	Point value
6012 a 3 f.e.o. longline opp. dir.	0,9
6012 b 3 f.e.o. longline opp. dir. three mills	1,5
6013 a 3 n.e.o. longline opp. dir.	0,9
6013 b 3 n.e.o. longline opp. dir. 6 s.r.l.	1,4
6013 c 3 n.e.o. longline opp. dir. through	1,0
6013 d 3 n.e.o. longline opp. dir. through 6 s.r.l.	1,6
6013 e 3 n.e.o. longline opp. dir. through three mills	1,8
6014 a 3 f.e.o. diagonal pull opp. dir.	0,9
6014 b 3 f.e.o. diagonal pull opp. dir. three mills	1,5
6017 a 6 n.e.o. shortline	0,8
6017 b 6 n.e.o. shortline 6 s.r.l.	1,6
6018 a 6 n.e.o. shortline bw.	2,0
6018 b 6 n.e.o. shortline 6 s.r.l. bw.	3,5
6019 a 6 n.e.o. shortline raiser	2,4
6019 b 6 n.e.o. shortline raiser frh.	2,7
6019 c 6 n.e.o. shortline 6 s.r.l. raiser	4,2
6019 d 6 n.e.o. shortline 6 s.r.l. raiser frh.	4,5
6026 a 3 f.e.o. double circle	0,7
6026 b 3 f.e.o. double circle 6 s.r.l.	1,3
6027 a 3 f.e.o. double circle bw.	1,9
6027 b 3 f.e.o. double circle 6 s.r.l. bw.	2,9
6028 a 3 f.e.o. double circle raiser	2,5
6028 b 3 f.e.o. double circle raiser frh.	3,0
6028 c 3 f.e.o. double circle 6 s.r.l. raiser	3,9
6028 d 3 f.e.o. double circle 6 s.r.l. raiser frh.	4,3
6029 a 3 f.e.o. double circle raiser bw. frh.	6,2
6029 b 3 f.e.o. double circle 6 s.r.l. raiser bw. frh.	7,0
6039 a 3 n.e.o. shortline opp. dir.	0,9
6039 b 3 n.e.o. shortline opp. dir. 6 s.r.l.	1,4
6039 c 3 n.e.o. shortline opp. dir. through	1,0
6039 d 3 n.e.o. shortline opp. dir. through 6 s.r.l.	1,6
6039 e 3 n.e.o. shortline opp. dir. through three mills	1,8
6039 f 3 n.e.o. half shortline opp. dir. count. s.r.	1,3
6039 g 3 n.e.o. shortline opp. dir. count. s.r.	1,7
6040 a 3 n.e.o. shortline opp. dir. bw.	2,2
6040 b 3 n.e.o. shortline opp. dir. through bw.	2,4
6040 c 3 n.e.o. half shortline opp. dir. count. s.r. bw.	3,0
6040 d 3 n.e.o. shortline opp. dir. count. s.r. bw.	3,5
6041 a 3 n.e.o. shortline opp. dir. raiser	2,7
6041 b 3 n.e.o. shortline opp. dir. raiser frh.	3,2
6041 c 3 n.e.o. shortline opp. dir. through raiser	2,8

UCI CYCLING REGULATIONS

Figure No. / Name of figure	Point value
6041 d 3 n.e.o. shortline opp. dir. through raiser frh.	3,3
6042 a 3 n.e.o. half shortline opp. dir. count. s.r. raiser bw. frh.	9,4
6042 b 3 n.e.o. shortline opp. dir. count. s.r. raiser bw. frh.	10,5
6052 a 2 f.e.o. shortline	0,9
6052 b 2 f.e.o. shortline 6 s.r.l.	1,4
6053 a 2 f.e.o. shortline bw.	2,8
6053 b 2 f.e.o. shortline 6 s.r.l. bw.	3,6
6061 a Triple C.	1,8
6062 a Triple C. bw.	3,6
6063 a Triple C. raiser	3,4
6063 b Triple C. raiser frh.	3,9
6064 a Triple C. raiser bw. frh.	6,0
6081 a 2 con. HC.	0,7
6081 b 2 con. C.	0,9
6081 c 2 con. HC. 2 con. s.r.l.	1,4
6081 d 2 con. C. 2 con. s.r.l.	1,6
6081 e 2 con. HC. 6 s.r.l.	2,6
6081 f 2 con. C. 6 s.r.l.	2,8
6082 a 2 con. HC. bw.	1,2
6082 b 2 con. C. bw.	1,4
6082 c 2 con. HC. 2con. s.r.l. bw.	1,9
6082 d 2 con. C. 2con. s.r.l. bw.	2,1
6082 e 2 con. HC. 6 s.r.l. bw.	3,1
6082 f 2 con. C. 6 s.r.l. bw.	3,3
6083 a 2 con. HC. raiser	1,6
6083 b 2 con. C. raiser	1,8
6083 c 2 con. HC. raiser frh.	1,8
6083 d 2 con. C. raiser frh.	2,1
6083 e 2 con. HC. 2 con. s.r.l. raiser	2,5
6083 f 2 con. C. 2 con. s.r.l. raiser	2,8
6083 g 2 con. HC. 2 con. s.r.l. raiser frh.	2,6
6083 h 2 con. C. 2 con. s.r.l. raiser frh.	3,0
6083 i 2 con. HC. 6 s.r.l. raiser	4,1
6083 j 2 con. C. 6 s.r.l. raiser	4,4
6083 k 2 con. HC. 6 s.r.l. raiser frh.	4,5
6083 l 2 con. C. 6 s.r.l. raiser frh.	4,8
6084 a 2 con. HC. raiser bw. frh.	2,3
6084 b 2 con. C. raiser bw. frh.	2,7
6084 c 2 con. HC. 2con. s.r.l. raiser bw. frh.	3,1
6084 d 2 con. C. 2con. s.r.l. raiser bw. frh.	3,4
6084 e 2 con. HC. 6 s.r.l. raiser bw. frh.	6,1
6084 f 2 con. C. 6 s.r.l. raiser bw. frh.	6,5

UCI CYCLING REGULATIONS

Figure No. / Name of figure	Point value
6092 a 2 con. f.e.o. longline raiser bw. frh.	2,6
6092 b 2 con. f.e.o. longline 3 s.r.l. 3 s.r.r. raiser bw. frh.	8,0
6096 a 2 con. shortline	0,8
6096 b 2 con. shortline 2 con. s.r.l.	1,3
6096 c 2 con. shortline 2 con. s.r.r.	1,5
6096 d 2 con. shortline 6 s.r.l.	1,9
6097 a 2 con. shortline bw.	1,6
6097 b 2 con. shortline 2 con. s.r.l. bw.	2,4
6097 c 2 con. shortline 6 s.r.l. bw	3,1
6098 a 2 con. shortline raiser	1,8
6098 b 2 con. shortline raiser frh.	2,1
6098 c 2 con. shortline 2 con. s.r.l. raiser	2,7
6098 d 2 con. shortline 2 con. s.r.l. raiser frh.	2,8
6098 e 2 con. shortline 6 s.r.l. raiser	4,5
6098 f 2 con. shortline 6 s.r.l. raiser frh.	4,8
6099 a 2 con. shortline raiser bw. frh.	2,3
6099 b 2 con. shortline 2 con. s.r.l. raiser bw. frh.	3,3
6099 c 2 con. shortline 6 s.r.l. raiser bw. frh.	6,6
6106 a 2 con. half shortline count. s.r.	1,1
6106 b 2 con. shortline count. s.r.	1,7
6107 a 2 con. half shortline count. s.r. bw.	2,0
6107 b 2 con. shortline count. s.r. bw.	2,6
6108 a 2 con. half shortline count. s.r. raiser	2,8
6108 b 2 con. shortline count. s.r. raiser	3,4
6108 c 2 con. half shortline count. s.r. raiser frh.	3,0
6108 d 2 con. shortline count. s.r. raiser frh.	3,6
6109 a 2 con. half shortline count. s.r. raiser bw. frh.	3,7
6109 b 2 con. shortline count. s.r. raiser bw. frh.	4,0
6121 a Three mills	1,2
6122 a Three mills bw.	1,5
6122 b Three mills bw. inside indiv.	2,6
6122 c Three mills bw. in- a. outside indiv.	2,9
6123 a Three mills raiser	2,3
6123 b Three mills raiser frh.	2,5
6123 c Three mills raiser frh. inside indiv.	3,7
6123 d Three mills raiser inside indiv. frh.	4,0
6123 e Three mills raiser frh. in- a. outside indiv.	3,9
6123 f Three mills raiser in- a. outside indiv. frh.	4,2
6124 a Three mills raiser bw. frh.	3,1
6124 b Three mills raiser bw. inside indiv. frh.	5,7

UCI CYCLING REGULATIONS

Figure No. / Name of figure	Point value
6124 c Three mills raiser bw. in- a. outside indiv. frh.	6,0
6133 a Three insiderings raiser	2,5
6133 b Three insiderings raiser inside indiv.	3,8
6133 c Three insiderings raiser inside indiv. frh.	4,1
6133 d Three insiderings raiser in- a. outside indiv.	4,1
6133 e Three insiderings raiser in- a. outside indiv. frh.	4,4
6134 a Three insiderings raiser bw.	3,1
6134 b Three insiderings raiser bw. inside indiv. frh.	5,8
6134 c Three insiderings raiser bw. in- a. outside indiv. frh.	6,2
6135 a Three outsiderings raiser	2,9
6135 b Three outsiderings raiser inside indiv.	4,2
6135 c Three outsiderings raiser inside indiv. frh.	4,5
6135 d Three outsiderings raiser in- a. outside indiv.	4,5
6135 e Three outsiderings raiser in- a. outside indiv. frh.	4,8
6136 a Three outsiderings raiser bw.	3,5
6136 b Three outsiderings raiser bw. inside indiv. frh.	6,2
6136 c Three outsiderings raiser bw. in- a. outside indiv. frh.	6,6
6151 a 3 con. HC.	0,9
6151 b 3 con. HC. raiser	1,2
6151 c 3 con. HC. 6 s.r.l.	1,9
6151 d 3 con. C. 6 s.r.l.	2,1
6152 a 3 con. HC. bw.	1,2
6152 b 3 con. C. bw.	1,4
6152 c 3 con. HC. 6 s.r.l. bw.	3,4
6152 d 3 con. C. 6 s.r.l. bw.	3,6
6153 a 3 con. HC. raiser	1,9
6153 b 3 con. C. raiser	2,2
6153 c 3 con. HC. raiser frh.	2,1
6153 d 3 con. C. raiser frh.	2,4
6153 e 3 con. HC. 6 s.r.l. raiser	4,2
6153 f 3 con. C. 6 s.r.l. raiser	4,5
6153 g 3 con. HC. 6 s.r.l. raiser frh.	4,7
6153 h 3 con. C. 6 s.r.l. raiser frh.	5,0
6154 a 3 con. HC. raiser bw. frh.	2,5
6154 b 3 con. C. raiser bw. frh.	3,0
6154 c 3 con. HC. 6 s.r.l. raiser bw. frh.	6,2
6154 d 3 con. C. 6 s.r.l. raiser bw. frh.	6,6
6165 a 3 con. shortline	0,8
6165 b 3 con. shortline 6 s.r.l.	2,0
6166 a 3 con. shortline bw.	1,7
6166 b 3 con. shortline 6 s.r.l. bw.	3,7
6167 a 3 con. shortline raiser	2,1

UCI CYCLING REGULATIONS

Figure No. / Name of figure	Point value
6167 b 3 con. shortline raiser frh.	2,3
6167 c 3 con. shortline 6 s.r.l. raiser	4,5
6167 d 3 con. shortline 6 s.r.l. raiser frh.	4,7
6168 a 3 con. shortline raiser bw. frh.	2,9
6168 b 3 con. shortline 6 s.r.l. raiser bw. frh.	6,4
6170 a 3 con. shortline opp. dir.	1,0
6170 b 3 con. shortline opp. dir. 6 s.r.l.	2,1
6171 a 3 con. shortline opp. dir. bw.	1,8
6171 b 3 con. shortline opp. dir. 6 s.r.l. bw.	3,9
6172 a 3 con. shortline opp. dir. raiser	2,1
6172 b 3 con. shortline opp. dir. raiser frh.	2,3
6172 c 3 con. shortline opp. dir. 6 s.r.l. raiser	4,6
6172 d 3 con. shortline opp. dir. 6 s.r.l. raiser frh.	4,8
6173 a 3 con. shortline opp. dir. raiser bw. frh.	3,0
6173 b 3 con. shortline opp. dir. 6 s.r.l. raiser bw. frh.	6,6
6186 a Surrounding 2 con. around 1	1,2
6187 a Surrounding 2 con. around 1 bw.	2,4
6196 a Two chains HC.	0,8
6196 b Two chains C.	1,1
6197 a Two chains HC. raiser	2,2
6197 b Two chains C. raiser	2,4
6197 c Two chains HC. raiser frh.	2,5
6197 d Two chains C. raiser frh.	2,7
6201 a Two saddlegrip HC.	0,8
6201 b Two saddlegrip C.	1,1
6208 a Two turbines raiser	2,4
6208 b Two turbines raiser frh.	2,6
6208 c Two turbines raiser frh. inside indiv.	3,8
6208 d Two turbines raiser inside indiv. frh.	4,1
6208 e Two turbines raiser frh. in- a. outside indiv.	4,0
6208 f Two turbines raiser in- a. outside indiv. frh.	4,2
6209 a Two turbines raiser bw. frh.	2,7
6209 b Two turbines raiser bw. inside indiv. frh.	5,9
6209 c Two turbines raiser bw. in- a. outside indiv. frh.	6,4
6209 d Two turbines 3 spin. raiser bw. in- a. outside indiv. frh.	7,5
6216 a Two mills	1,5
6217 a Two mills bw.	1,9
6217 b Two mills bw. inside indiv.	3,0
6217 c Two mills bw. in- a. outside indiv.	3,3

UCI CYCLING REGULATIONS

Figure No. / Name of figure	Point value
6218 a Two mills raiser	2,5
6218 b Two mills raiser frh.	2,7
6218 c Two mills raiser frh. inside indiv.	4,1
6218 d Two mills raiser inside indiv. frh.	4,3
6218 e Two mills raiser frh. in- a. outside indiv.	4,3
6218 f Two mills raiser in- a. outside indiv. frh.	4,6
6219 a Two mills raiser bw. frh.	3,0
6219 b Two mills raiser bw. inside indiv. frh.	6,1
6219 c Two mills raiser bw. in- a. outside indiv. frh.	6,4
6228 a Two insiderings raiser	2,6
6228 b Two insiderings raiser inside indiv.	4,4
6228 c Two insiderings raiser inside indiv. frh.	4,6
6228 d Two insiderings raiser in- a. outside indiv.	4,6
6228 e Two insiderings raiser in- a. outside indiv. frh.	4,8
6229 a Two insiderings raiser bw.	3,0
6229 b Two insiderings raiser bw. inside indiv. frh.	5,8
6229 c Two insiderings raiser bw. in- a. outside indiv. frh.	6,3
6236 a Two outsiderings raiser	3,1
6236 b Two outsiderings raiser inside indiv.	4,8
6236 c Two outsiderings raiser inside indiv. frh.	5,0
6236 d Two outsiderings raiser in- a. outside indiv.	5,0
6236 e Two outsiderings raiser in- a. outside indiv. frh.	5,2
6236 f Two outsiderings HS / insiderings HS raiser	3,6
6237 a Two outsiderings raiser bw.	3,9
6237 b Two outsiderings raiser bw. inside indiv. frh.	6,7
6237 c Two outsiderings raiser bw. in- a. outside indiv. frh.	7,2
6237 d Two outsiderings HS / insiderings HS raiser bw.	4,3
6251 a Two stars outside bw. inside indiv.	4,0
6252 a Two stars outside raiser bw. inside indiv. frh.	7,3
6271 a 6 con. HC.	1,7
6271 b 6 con. C.	1,9
6271 c 6 con. HC. 2 con. s.r.l.	2,2
6271 d 6 con. C. 2 con. s.r.l.	2,5
6271 e 6 con. HC. 6 s.r.l.	2,6
6271 f 6 con. C. 6 s.r.l.	2,9
6272 a 6 con. HC. bw.	2,1
6272 b 6 con. C. bw.	2,4
6272 c 6 con. HC. 2 con. s.r.l. bw.	3,0
6272 d 6 con. C. 2 con. s.r.l. bw.	3,2
6272 e 6 con. HC. 6 s.r.l. bw.	4,4
6272 f 6 con. C. 6 s.r.l. bw.	4,6
6273 a 6 con. HC. raiser	2,7

UCI CYCLING REGULATIONS

Figure No. / Name of figure	Point value
6273 b 6 con. C. raiser	2,9
6273 c 6 con. HC. raiser frh.	2,8
6273 d 6 con. C. raiser frh.	3,0
6273 e 6 con. HC. 2 con. s.r.l. raiser	3,1
6273 f 6 con. C. 2 con. s.r.l. raiser	3,4
6273 g 6 con. HC. 2 con. s.r.l. raiser frh.	3,2
6273 h 6 con. C. 2 con. s.r.l. raiser frh.	3,6
6273 i 6 con. HC. 6 s.r.l. raiser	5,3
6273 j 6 con. C. 6 s.r.l. raiser	5,5
6273 k 6 con. HC. 6 s.r.l. raiser frh.	5,4
6273 l 6 con. C. 6 s.r.l. raiser frh.	5,6
6274 a 6 con. HC. raiser bw. frh.	3,5
6274 b 6 con. C. raiser bw. frh.	3,7
6274 c 6 con. HC. 2 con. s.r.l. raiser bw. frh.	3,8
6274 d 6 con. C. 2 con. s.r.l. raiser bw. frh.	4,1
6274 e 6 con. HC. 6 s.r.l. raiser bw. frh.	7,1
6274 f 6 con. C. 6 s.r.l. raiser bw. frh.	7,5
6281 a 6 con. shortline	2,0
6281 b 6 con. shortline 2 con. s.r.l.	2,5
6281 c 6 con. shortline 6 s.r.l.	2,9
6281 d 6 n.e.o. half shortline count. s. r.	1,0
6281 e 6 n.e.o. shortline count. s.r.	1,2
6282 a 6 con. shortline bw.	2,3
6282 b 6 con. shortline 2 con. s.r.l. bw.	3,1
6282 c 6 con. shortline 6 s.r.l. bw.	4,6
6283 a 6 con. shortline raiser	2,9
6283 b 6 con. shortline raiser frh.	3,0
6283 c 6 con. shortline 2 con. s.r.l. raiser	3,4
6283 d 6 con. shortline 2 con. s.r.l. raiser frh.	3,6
6283 e 6 con. shortline 6 s.r.l. raiser	5,6
6283 f 6 con. shortline 6 s.r.l. raiser frh.	5,7
6284 a 6 con. shortline raiser bw. frh.	3,5
6284 b 6 con. shortline 2 con. s.r.l. raiser bw. frh.	4,1
6284 c 6 con. shortline 6 s.r.l. raiser bw. frh.	7,5
6284 d 6 n.e.o. half shortline count. s.r. raiser bw. frh.	8,9
6284 e 6 n.e.o. shortline count. s.r. raiser bw. frh.	10,3
6291 a Surrounding 5 con. around 1	2,4
6292 a Surrounding 5 con. around 1 bw.	3,0
6293 a Surrounding 5 con. around 1 raiser	3,2
6293 b Surrounding 5 con. around 1 raiser frh.	3,3
6294 a Surrounding 5 con. around 1 raiser bw. frh.	3,8
6301 a Coach HC.	1,7
6301 b Coach C.	1,9

UCI CYCLING REGULATIONS

Figure No. / Name of figure	Point value
6302 a Coach HC. raiser	2,7
6302 b Coach C. raiser	3,0
6311 a Snake HC.	1,7
6311 b Snake C.	1,9
6316 a Chain HC.	1,7
6316 b Chain C.	1,9
6317 a Chain HC. raiser frh.	2,8
6317 b Chain C. raiser frh.	3,2
6318 a Chain HC. raiser bw. frh.	3,2
6318 b Chain C. raiser bw. frh.	3,7
6321 a Saddlegrip HC.	1,6
6321 b Saddlegrip C.	1,8
6322 a Saddlegrip pass through	2,0
6323 a Saddlegripring	2,0
6323 b Saddlegripring 6 s.r.r.	2,5
6324 a Saddlegripring bw.	2,7
6324 b Saddlegripring bw. inside indiv.	4,6
6324 c Saddlegripring bw. in- a. outside indiv.	4,8
6331 a 2 con. wingmill opp. dir. door bw.	4,6
6331 b 2 con. wingmill opp. dir. door sim. bw.	5,1
6332 a 2 con. wingmill opp. dir. door raiser	4,7
6332 b 2 con. wingmill opp. dir. door raiser frh.	5,0
6332 c 2 con. wingmill opp. dir. door sim. raiser	5,4
6332 d 2 con. wingmill opp. dir. door sim. raiser frh.	5,7
6333 a 2 con. wingmill opp. dir. door raiser bw. frh.	6,9
6333 b 2 con. wingmill opp. dir. door sim. raiser bw. frh.	7,6
6341 a 3 con. wingmill	1,6
6341 b 3 con. wingmill HS 6 s.r.r.	2,3
6341 c 3 con. wingmill 6 s.r.r.	2,6
6342 a 3 con. wingmill bw.	2,2
6342 b 3 con. wingmill bw. inside indiv.	4,2
6342 c 3 con. wingmill bw. in- a. outside indiv.	4,5
6343 a 3 con. wingmill raiser	2,4
6343 b 3 con. wingmill raiser frh.	2,6
6343 c 3 con. wingmill raiser frh. inside indiv.	3,9
6343 d 3 con. wingmill raiser inside indiv. frh.	4,3
6343 e 3 con. wingmill raiser frh. in- a. outside indiv.	4,4
6343 f 3 con. wingmill raiser in- a. outside indiv. frh.	4,7

UCI CYCLING REGULATIONS

Figure No. / Name of figure	Point value
6344 a 3 con. wingmill raiser bw.	3,2
6344 b 3 con. wingmill raiser bw. frh.	3,4
6344 c 3 con. wingmill raiser bw. inside indiv. frh.	5,8
6344 d 3 con. wingmill raiser bw. in- a. outside indiv. frh.	6,1
6345 a 3 con. wingmill HS 6 s.r.r. raiser bw. frh.	8,3
6345 b 3 con. wingmill 6 s.r.r. raiser bw. frh.	8,5
6351 a 2 con. wingmill	1,7
6351 b 2 con. wingmill HS 2 con. s.r.r.	2,0
6351 c 2 con. wingmill 2 con. s.r.r.	2,2
6351 d 2 con. wingmill HS 6 s.r.r.	2,4
6351 e 2 con. wingmill 6 s.r.r.	2,6
6352 a 2 con. wingmill bw.	2,3
6352 b 2 con. wingmill HS 2 con. s.r.r. bw.	2,7
6352 c 2 con. wingmill 2 con. s.r.r. bw.	2,9
6352 d 2 con. wingmill bw. inside indiv.	4,3
6352 e 2 con. wingmill bw. in- a. outside indiv.	4,6
6353 a 2 con. wingmill raiser	2,4
6353 b 2 con. wingmill raiser frh.	2,6
6353 c 2 con. wingmill raiser frh. inside indiv.	4,1
6353 d 2 con. wingmill raiser inside indiv. frh.	4,5
6353 e 2 con. wingmill raiser frh. in- a. outside indiv.	4,5
6353 f 2 con. wingmill raiser in- a. outside indiv. frh.	4,9
6354 a 2 con. wingmill raiser bw.	3,2
6354 b 2 con. wingmill raiser bw. frh.	3,4
6354 c 2 con. wingmill raiser bw. inside indiv. frh.	5,9
6354 d 2 con. wingmill raiser bw. in- a. outside indiv. frh.	6,3
6355 a 2 con. wingmill HS 2 con. s.r.r. raiser bw. frh.	3,7
6355 b 2 con. wingmill 2 con. s.r.r. raiser bw. frh.	3,9
6355 c 2 con. wingmill HS 6 s.r.r. raiser bw. frh.	8,3
6355 d 2 con. wingmill 6 s.r.r. raiser bw. frh.	8,9
6362 a 2 con. wingring bw.	2,5
6363 a 2 con. wingring raiser	2,6
6363 b 2 con. wingring raiser frh.	2,8
6363 c 2 con. wingring raiser frh. inside indiv.	4,3
6363 d 2 con. wingring raiser inside indiv. frh.	4,7
6363 e 2 con. wingring raiser frh. in- a. outside indiv.	4,7
6363 f 2 con. wingring raiser in- a. outside indiv. frh.	5,1
6364 a 2 con. wingring raiser bw.	3,5
6364 b 2 con. wingring raiser bw. frh.	3,9
6364 c 2 con. wingring raiser bw. inside indiv. frh.	6,4
6364 d 2 con. wingring raiser bw. in- a. outside indiv. frh.	6,8
6371 a 3 con. wingmill mill with 4 f.e.o. C. bw.	3,2

UCI CYCLING REGULATIONS

Figure No. / Name of figure	Point value
6371 b 3 con. wingring insidering with 4 f.e.o. C. bw.	3,3
6372 a 3 con. wingmill mill with 4 f.e.o. C. raiser	3,6
6372 b 3 con. wingmill mill with 4 f.e.o. C. raiser frh.	3,9
6372 c 3 con. wingring insidering with 4 f.e.o. C. raiser	3,8
6372 d 3 con. wingring insidering with 4 f.e.o. C. raiser frh.	4,1
6373 a 3 con. wingmill mill with 4 f.e.o. C. raiser bw. frh.	5,6
6373 b 3 con. wingring insidering with 4 f.e.o. C. raiser bw. frh.	5,9
6376 a 2 con. wingmill mill with 3 f.e.o. C. bw.	3,0
6376 b 2 con. wingring insidering with 3 f.e.o. C. bw.	3,2
6377 a 2 con. wingmill mill with 3 f.e.o. C. raiser	3,5
6377 b 2 con. wingmill mill with 3 f.e.o. C. raiser frh.	3,8
6377 c 2 con. wingring insidering with 3 f.e.o. C. raiser	3,6
6377 d 2 con. wingring insidering with 3 f.e.o. C. raiser frh.	3,9
6378 a 2 con. wingmill mill with 3 f.e.o. C. raiser bw. frh.	5,4
6378 b 2 con. wingring insidering with 3 f.e.o. C. raiser bw. frh.	5,6
6378 c 2 con. wingmill mill with 3 spin. raiser bw. frh.	9,0
6386 a Mill	2,2
6386 b Mill 6 s.r.r.	3,0
6387 a Mill bw.	2,8
6387 b Mill bw. inside indiv.	5,1
6387 c Mill bw. in- a. outside indiv.	5,5
6388 a Mill raiser	3,2
6388 b Mill raiser frh.	3,4
6388 c Mill raiser frh. inside indiv.	5,0
6388 d Mill raiser inside indiv. frh.	5,4
6388 e Mill raiser frh. in- a. outside indiv.	5,2
6388 f Mill raiser in- a. outside indiv. frh.	5,7
6389 a Mill raiser bw. frh.	3,8
6389 b Mill raiser bw. inside indiv. frh.	7,6
6389 c Mill raiser bw. in- a. outside indiv. frh.	8,0
6396 a Insidering around 2 raiser	2,0
6396 b Insidering around 2 raiser inside indiv.	4,7
6396 c Insidering around 2 raiser inside indiv. frh.	5,1
6396 d Insidering around 2 raiser in- a. outside indiv.	5,2
6396 e Insidering around 2 raiser in- a. outside indiv. frh.	5,3
6397 a Insidering around 2 raiser bw. frh.	4,1
6397 b Insidering around 2 raiser bw. inside indiv. frh.	7,4
6397 c Insidering around 2 raiser bw. in- a. outside indiv. frh.	7,7
6403 a Insidering raiser	3,0
6403 b Insidering raiser inside indiv.	4,0
6403 c Insidering raiser inside indiv. frh.	4,4

UCI CYCLING REGULATIONS

Figure No. / Name of figure	Point value
6403 d Insidering raiser in- a. outside indiv.	4,6
6403 e Insidering raiser in- a. outside indiv. frh.	5,0
6404 a Insidering raiser bw.	4,1
6404 b Insidering raiser bw. inside indiv. frh.	6,4
6404 c Insidering raiser bw. in- a. outside indiv. frh.	6,7
6412 a Ring with opp. grips raiser	3,3
6412 b Ring with opp. grips HS / Insidering HS raiser	3,9
6412 c Ring with opp. grips raiser inside indiv.	4,3
6412 d Ring with opp. grips raiser inside indiv. frh.	4,7
6412 e Ring with opp. grips raiser in- a. outside indiv.	4,9
6412 f Ring with opp. grips raiser in- a. outside indiv. frh.	5,3
6413 a Ring with opp. grips raiser bw.	4,3
6413 b Ring with opp. grips HS / Insidering HS raiser bw.	4,9
6413 c Ring with opp. grips raiser bw. inside indiv. frh.	6,7
6413 d Ring with opp. grips raiser bw. in- a. outside indiv. frh.	7,0
6417 a Outsidering raiser	3,9
6417 b Outsidering raiser inside indiv.	5,0
6417 c Outsidering raiser inside indiv. frh.	5,4
6417 d Outsidering raiser in- a. outside indiv.	5,5
6417 e Outsidering raiser in- a. outside indiv. frh.	5,9
6417 f Outsidering HS / Insidering HS raiser	4,5
6418 a Outsidering raiser bw.	4,9
6418 b Outsidering raiser bw. inside indiv. frh.	7,4
6418 c Outsidering raiser bw. in- a. outside indiv. frh.	7,9
6418 d Outsidering HS / Insidering HS raiser bw.	5,3
6425 a Half door	1,0
6425 b Door	1,4
6425 c Half opp. dir. door	1,8
6425 d Opp. dir. door	2,0
6425 e Opp. dir. door sim.	2,5
6426 a Half door bw.	3,5
6426 b Door bw.	3,9
6426 c Half opp. dir. door bw.	4,1
6426 d Opp. dir. door bw.	4,3
6426 e Opp. dir. door sim. bw.	5,2
6427 a Half door raiser	3,9
6427 b Door raiser	4,5
6427 c Half door raiser frh.	4,2
6427 d Door raiser frh.	4,8
6427 e Half opp. dir. door raiser	4,8
6427 f Opp. dir. door raiser	5,4
6427 g Half opp. dir. door raiser frh.	5,1
6427 h Opp. dir. door raiser frh.	5,7
6427 i Opp. dir. door sim. raiser	5,6
6427 j Opp. dir. door sim. raiser frh.	5,9

UCI CYCLING REGULATIONS

Figure No. / Name of figure	Point value
6428 a Half door raiser bw. frh.	6,0
6428 b Door raiser bw. frh.	6,8
6428 c Half opp. dir. door raiser bw. frh.	7,7
6428 d Opp. dir. door raiser bw. frh.	8,5
6428 e Opp. dir. door sim. raiser bw. frh.	8,9
6428 f Mill with half opp. dir. door raiser bw. frh.	8,6
6428 g Mill with opp. dir. door raiser bw. frh.	9,2
6428 h Mill with opp. dir. door sim. raiser bw. frh.	9,5
6436 a Double door	2,2
6436 b Double door opp. dir.	2,0
6437 a Double door bw.	5,2
6437 b Double door opp. dir. bw.	4,8
6438 a Double door raiser bw. frh.	9,2
6438 b Double door opp. dir. raiser bw. frh.	8,5
6439 a Double door moving synchronous door raiser	4,0
6439 b Double door moving synchronous door raiser frh.	4,3
6440 a Double door moving synchronous door raiser bw. frh.	6,9
6452 a Half door ring raiser	3,5
6452 b Door ring raiser	4,2
6453 a Half door ring raiser bw.	5,0
6453 b Door ring raiser bw.	6,0
6462 a Half double door ring raiser	4,1
6462 b Double door ring raiser	4,8
6463 a Half double door ring raiser bw.	6,4
6463 b Double door ring raiser bw.	6,8
6471 a Star inside 6 s.r.l.	2,5
6472 a Star inside raiser	3,3
6472 b Star inside raiser inside indiv.	4,9
6472 c Star inside raiser inside indiv. frh.	5,3
6472 d Star inside raiser bw. inside indiv. frh.	7,7
6481 a Star outside bw. inside indiv.	4,9
6481 b Star outside 6 s.r.l. bw. inside indiv.	5,7
6482 a Star opp. dir.	2,0
6482 b Star opp. dir. raiser	3,6
6482 c Star opp. dir. raiser inside indiv. frh.	5,8
6482 d Star opp. dir. raiser bw. inside indiv. frh.	8,0
6483 a Star outside raiser	4,1
6483 b Star outside raiser bw. inside indiv. frh.	7,2

UCI CYCLING REGULATIONS

Figure No. / Name of figure	Point value
6483 c Star outside 6 s.r.l. raiser bw. inside indiv. frh.	8,4
6485 a Two stars inside raiser ½ turn on the spot	5,9
6486 a Star inside raiser ½ turn on the spot	6,1
6486 b Star inside raiser 1 turn on the spot	7,2
6496 a 2 con. raiser ½ turn on the spot T (5,9 - 6,5)	5,6
6496 b 2 con. raiser 1 turn on the spot T (7,1)	6,8
6496 c 2 con. raiser 1½ turns on the spot	7,4
6496 d 3 con. raiser ½ turn on the spot T (6,3 - 6,9)	5,9
6496 e 3 con. raiser 1 turn on the spot T (7,4)	7,1
6496 f 3 con. raiser 1½ turns on the spot	7,7
6496 g 6 con. raiser ½ turn on the spot T (6,9 - 7,5)	6,4
6496 h 6 con. raiser 1 turn on the spot T (8,0)	7,6
6496 i 6 con. raiser 1½ turns on the spot	8,3

		Given		
Shown		6496a	6496b	6496c
		½	1	1 ½
	½	5,6		
	1	5,9	6,8	
	1 ½	6,5	7,1	7,4

		Given		
		6496d	6496e	6496f
		½	1	1 ½
	½	5,9		
	1	6,3	7,1	
	1 ½	6,9	7,4	7,7

		Given		
Shown		6496g	6496h	6496i
		½	1	1 ½
	½	6,4		
	1	6,9	7,6	
	1 ½	7,5	8,0	8,3

(text modified on 01.01.16; 01.01.17)

**Chapter XI EXPLANATIONS OF FIGURES ARTISTIC CYCLING
TEAM 6**

8.11.001 Artistic Cycling Team 6

6 following each other half circle

All riders are riding with same distances between each other and at same distances to the 4-metre-circle, outside of the 4-metre-circle.

A figure ends when, the 4-metre-circle is rounded half at the outside of the 4-metre-circle.

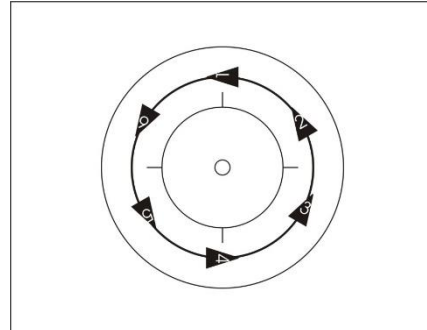

**6001 a
6002 a
6003 a
6003 c
6004 a**

6 following each other Circle

All riders are riding with same distances between each other and at same distances to the 4-metre-circle, outside of the 4-metre-circle.

A figure ends when, the 4-metre-circle is rounded completely at the outside of the 4-metre-circle.

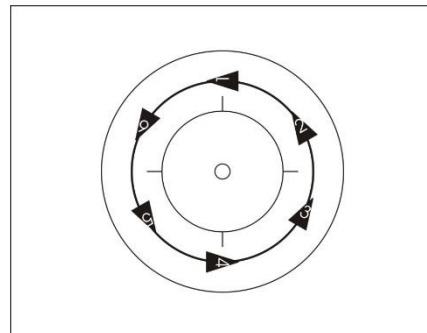

**6001 b
6002 b
6003 b
6003 d
6004 b**

6 following each other half circle 6 single rings left

All riders are riding with same distances between each other and at same distances to the 4-metre-circle, outside of the 4-metre-circle. During the figure the riders have to perform simultaneously four same sized and uniform single ring left. The half circle has to be performed at least 2 metre before and 2 metre after the single rings.

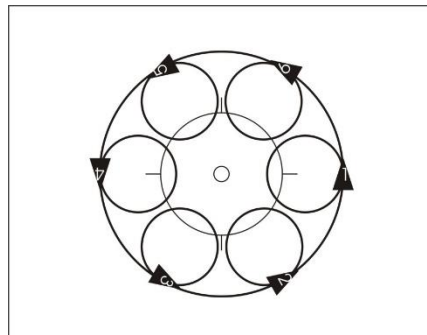

**6001 c
6002 c
6003 e
6003 f
6004 c**

A figure ends when the 4-metre-circle is rounded half at the outside of the 4-metre-circle.

Single ring left (8.3.029)

6 following each other circle 6 single rings left

All riders are riding with same distances between each other and at same distances to the 4-metre-circle, outside of the 4-metre-circle. During the figure the riders have to perform simultaneously four same sized and uniform single ring left. The half circle has to be performed at least 2 metre before and 2 metre after the single rings.

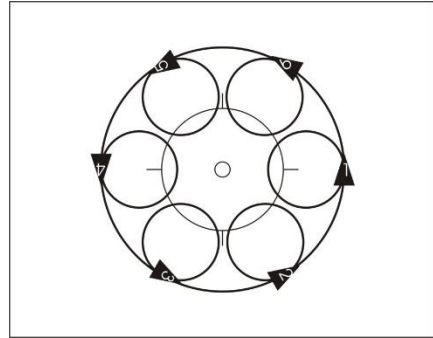

6001 d
6002 d
6003 f
6003 h
6004 d

A figure ends when the 4-metre-circle is rounded completely at the outside of the 4-metre-circle.

Single ring left (8.3.029)

6 following each other half circle 3 single rings left 3 single rings right

All riders are riding with same distances between each other and at same distances to the 4-metre-circle, outside of the 4-metre-circle. During the figure the riders have to perform simultaneously three same sized and uniform single rings right and three same sized and uniform single rings left. The riders which are riding on the same axis have to perform the same type of single ring. The circle has to be performed 2 metres before and 2 metres after the single rings.

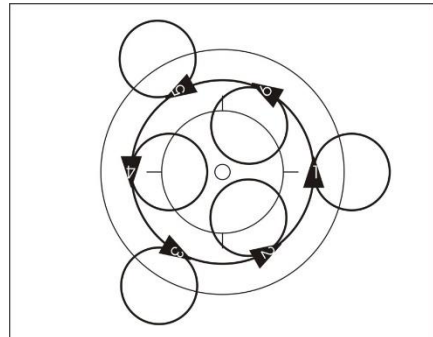

6001 e

The figure ends, when the 4-metre-circle is rounded half at the outside of the 4-metre-circle.

The figure ends, when the 4-metre-circle is rounded half at the outside of the 4-metre-circle.

Single ring left (8.3.029)

Single ring right (8.3.030)

6 following each other circle 3 single ring left 3 single ring right

All riders are riding with same distances between each other and at same distances to the 4-metre-circle, outside of the 4-metre-circle. During the figure the riders have to perform simultaneously three same sized and uniform single rings right and three same sized and uniform single rings left. The riders which are riding on the same axis have to perform the same type of single ring. The circle has to be performed 2 metres before and 2 metres after the single rings.

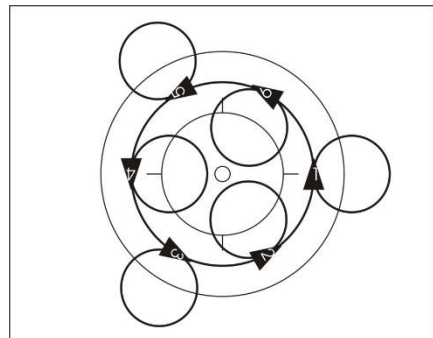

6001 f

The figure ends, when the 4-metre-circle is rounded completely at the outside of the 4-metre-circle.

The figure ends, when the 4-metre-circle is rounded completely at the outside of the 4-metre-circle.

Single ring left (8.3.029)

Single ring right (8.3.030)

6 following each other half circle 6 single rings right

All riders are riding with same distances between each other and at same distances to the 4-metre-circle, outside of the 4-metre-circle. During the figure the riders have to perform simultaneously four same sized and uniform single rings right. The half circle has to be performed 2 metres before and 2 metres after the single rings.

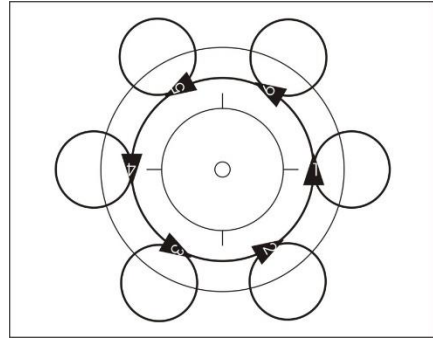

6001 g

The figure ends when the 4-metre-circle is rounded half at the outside of the 4-metre-circle.

Single ring right (8.3.030)

6 following each other circle 6 single rings right

All team members riding with same distances between each other and at same distances to the 4-metre-circle, outside of the 4-metre-circle. During the figure the riders have to perform simultaneously four same sized, and uniform singles ring right. The circle has to be performed 2 metre before and 2 metre after the single ring right.

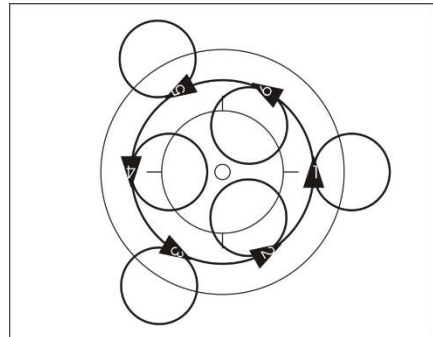

6001 h

The figure ends when the 4-metre-circle is rounded completely at the outside of the 4-metre-circle.

Single ring right (8.3.030)

6 following each diagonal pull

All riders are following each other crossing the riding-area, from a corner in a straight line over the middle of the riding-area to the opposite corner.

The distance between rider 1 and 2, may not be more than 2 metres and has to be identical to the distance between rider 2 and 3, between the riders 3 and 4, between the riders 4 and 5 and between the riders 5 and 6.

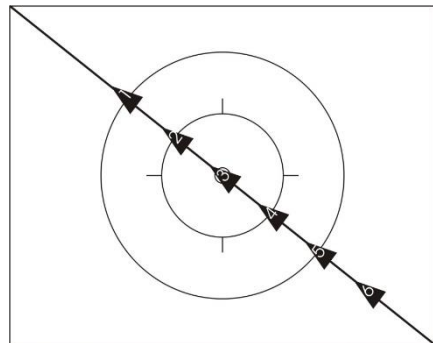

6006 a

The way of stretch for the diagonal pull, for each rider, will start 1 metre from the starting corner until 1 metre before the opposite corner.

**6 following each other diagonal pull
3 s.r.l. 3 s.r.r.**

All riders are following each other crossing the riding-area, from a corner in a straight line over the middle of the riding-area to the opposite corner.

The distance between rider 1 and 2, may not be more than 2 metres and has to be identical to the distance between rider 2 and 3, between the riders 3 and 4, between the riders 4 and 5 and between the riders 5 and 6. The way of stretch for the diagonal pull, for each rider, will start at the distance of 1 metre from the starting corner until 1 metre before the opposite corner.

During the figure the riders have to perform 3 single rings right and 3 single rings left simultaneously. Rider 1, 3 and 5 and rider 2, 4 and 6 have to perform the same type of a single ring.

The figure has to be performed at least 2 metres before of and 2 metres after the single rings.

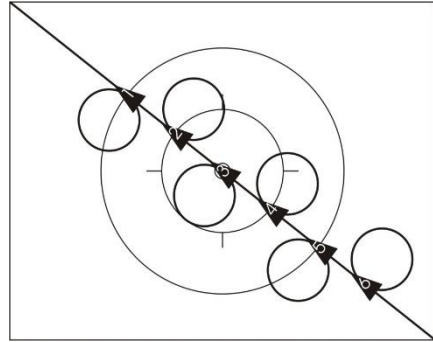

6006 b

Single ring left (8.3.029)

Single ring right (8.3.030)

6 following each other half eight

All riders following each other, on one common half eight. The distance between rider 1 and 2, may not be more than 2 metres and has to be identical to the distance between rider 2 and 3, between the riders 3 and 4, between the riders 4 and 5 and between the riders 5 and 6.

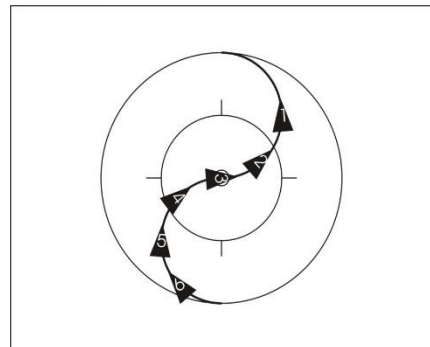

6007 a
6008 a
6010 a

Half Eight (8.3.035)

6 following each other eight

All riders following each other, on one common eight. The distance between rider 1 and 2, may not be more than 2 metres and has to be identical to the distance between rider 2 and 3, between the riders 3 and 4, between the riders 4 and 5 and between the riders 5 and 6.

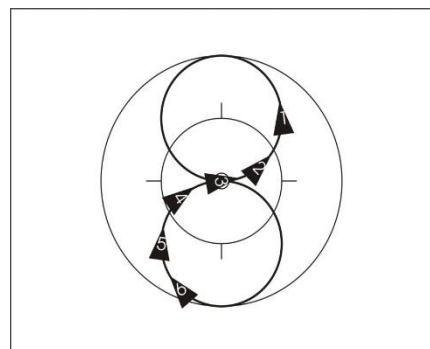

6007 b
6008 b
6010 b

Eight (8.3.036)

6 following each other eight through

All riders are riding at the same distance between each other and at they have all the same distance to a spot on one half of the riding-area.

Riders 1, 3 and 5 perform an eight without changing the distances between each other. After completing the eight they circle the spot at least one time. Riders 2, 4 and 6 circle the spot at least one time. After circling the spot they perform an eight without changing the distance between each other.

The figure ends at the moment that all riders are riding at the same distances towards each other, while circling the spot. The distance of each rider to the spot must be the same.

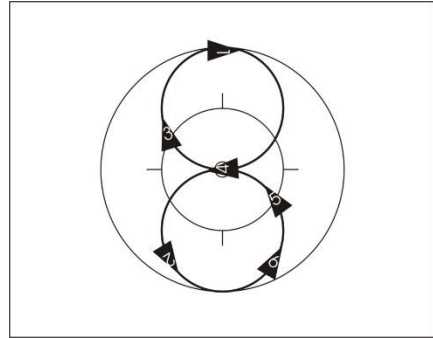

6007 c
6008 c
6010 c

Eight (8.3.036)

6 following each other longline

6011

All riders are riding at the same distance between each other on an axis which runs parallel to the long side of the riding-area. The distance between rider 1 and 2 may not occur more than 2 metres and must be the same as between rider 2 and 3, between rider 3 and 4, between rider 4 and 5 and between rider 5 and 6.

If in the text is mentioned, 3 single rings left 3 single rings right, during the figure 3 single rings right and 3 single rings left simultaneous from each group have to be executed with the same size and uniform. Rider 1, 3 and 5 on one side, and rider 2, 4 and 6 on the other side have to perform the same kind of single ring. The longline has to be performed at least 2 metres before of and 2 metres after the single rings.

Longline (8.3.042)

Single ring left (8.3.029)

Single ring right (8.3.030)

3 following each other longline opposite direction

6012

Each 3 riders are riding following each other. The distance between rider 1, 2 and 3 must be identical to the distance between riders 4, 5 and 6 and may not occur more than 2 metres. One group will start from the short side of the riding-area and ride to the opposite side of the riding-area. The other group will start from the other short side and will ride to the opposite side of the riding-area. Both groups are riding with the same speed during this figure.

If in the text is mentioned three mills, during the figure three mills simultaneous from each group have to be executed. As soon as all riders are on the same level, the new groups have to connect simultaneous into a mill. The riders are connected with their left hands and are riding with same distances to each other a complete circle (360°) around a spot. The longline opposite direction has to be performed at least 2 metres before of and 2 metres after the three mills.

Longline (8.3.042)

3 next to each other longline opposite direction

6013

Each 3 riders are riding next to each other without grip connection on one axis which runs parallel to the long side of the riding-area. The distance between riders 1 and 2 must be identical to the distance between riders 2 and 3 also between riders 4 and 5 and between riders 5 and 6. All riders are riding on an axis parallel to the long side of the riding-area. One group will start from the short side of the riding-area and ride to the opposite side of the riding-area. The other group will start from the other short side and will ride to the opposite side of the riding-area. Both groups are riding with the same speed during this figure.

If in the text is mentioned, 6 single rings left, during the figure 6 single rings left simultaneous from each group have to be executed with same size and uniform.

If in the text is mentioned, through, after half of the way of stretch the riders are riding through the space which is built from three riders.

If in the text is mentioned, three mills, during the figure three mills simultaneous from each group have to be executed. As soon as all riders are on the same level, the new groups have to connect simultaneous into a mill. The riders are connected with their left hands and are riding with same distances to each other a complete circle (360°) around a spot.

The longline opposite direction has to be performed at least 2 metres before of and 2 metres after the single rings or after the mills.

Longline (**8.3.042**)
Single ring left (**8.3.029**)

3 following each other diagonal pull opposite direction

6014

Each 3 riders are riding following each other. The distance between rider 1, 2 and 3 must be identical to the distance between riders 4, 5 and 6 and may not occur more than 2 metres. One group will start from one corner of the riding-area and ride to the opposite corner of the riding-area. The other group will start from the other corner and will ride to the opposite corner of the riding-area.

If in the text is mentioned three mills, during the figure three mills simultaneous from each group have to be executed. As soon as all riders are on the same level, the new groups have to connect simultaneous into a mill. The riders are connected with their left hands and are riding with same distances to each other a complete circle (360°) around a spot. The longline opposite direction has to be performed at least 2 metres before of and 2 metres after the mills.

Diagonal pull (**8.3.042**)

6 next to each other shortline

All riders are riding next to each other, without grip connection, each on an own imaginary axis parallel to the short side of the riding-area, and each on the same axis parallel which runs towards the long side of the riding-area. The distance between rider 1 and 2 has to be identical with the distance between rider 2 and 3, between rider 3 and 4, between rider 4 and 5 and between rider 5 and 6. The way of stretch for the shortline will start 1 metre from the long side of the riding-area until 1 metre distance before the opposite border of the riding-area.

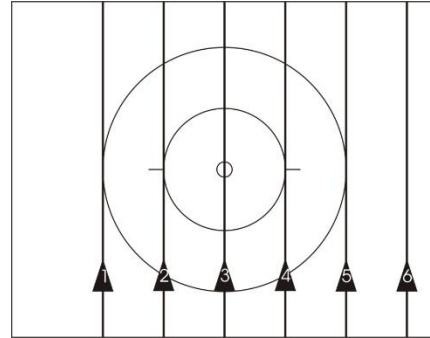

6017 a
6018 a
6019 a
6019 b

6 next to each other shortline 6 single rings left

All riders are riding next to each other, without grip connection, each on an axis parallel to the short side of the riding-area and each on the same axis parallel which runs towards the long side of the riding-area. The distance between rider 1 and 2 has to be identical with the distance between rider 2 and 3, between rider 3 and 4, between rider 4 and 5 and between rider 5 and 6. During the figure, each rider performs simultaneously a same sized and uniform single ring left. The figure has to be performed 2 metre before and 2 metre after the single rings. The way of stretch for the shortline will start 1 metre from the long side of the riding-area until 1 metre distance before the opposite border of the riding-area.

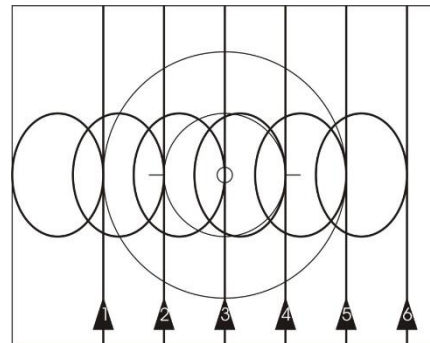

6017 b
6018 b
6019 c
6019 d

Single ring left (8.3.029)

3 following each other double circle

Each 3 riders following each other at the same distances to each other while both are surrounding the same point on the riding-area. The centre of each point (one for each group) is situated the same distance to the centre of the riding-area on the longitudinal axis. Each three riders (one of each group) are riding on the same longitudinal axis during the whole way of stretch of the circle.

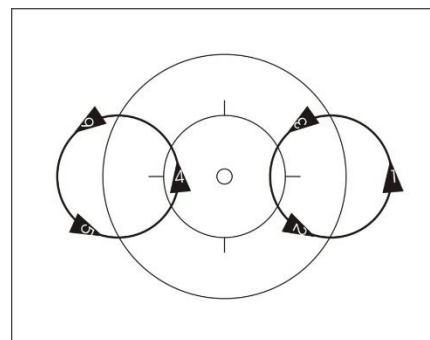

6026 a
6027 a
6028 a
6028 b
6029 a

The riding-area is divided by the transverse axis. The diameter of each circle of the double circle as a minimum of 4 metre. The figure ends, when the point is surrounded completely.

**3 following each other double circle
6 s.r.l.**

Each 3 riders following each other at the same distances to each other while both are surrounding the same point on the riding-area. The centre of each circle (one for each group) is situated the same distance to the centre of the riding-area on the longitudinal axis. Each three riders (one of each group) are riding on the same longitudinal axis during the whole way of stretch of the circle.

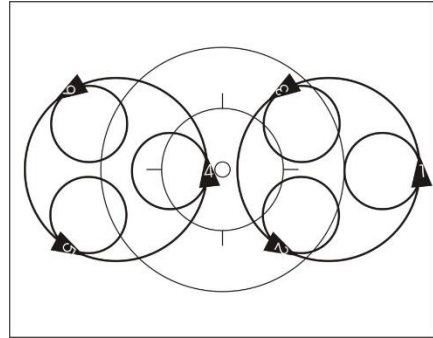

6026 b
6027 b
6028 c
6028 d
6029 b

The riding-area is divided by the transverse axis. The diameter of each circle of the double circle as a minimum of 4 metre.

During the figure, each rider performs simultaneously a same sized and uniform single ring left.

The double circle has to be performed 2 metres before and 2 metres after the single ring left.

The figure ends when the point is rounded completely.

Single ring left (8.3.029)

**3 next to each other shortline
opposite direction**

Each 3 riders are riding as group next to each other without grip connection on an axis which runs parallel to the long side of the riding-area. The distance between rider 1 and 2 has to be identical with the distance between rider 2 and 3, between rider 4 and 5 and between rider 5 and 6. All riders are riding on an axis parallel to the short side of the riding-area. One group will start from the long side of the riding-area and ride to the opposite side of the riding-area. The other group will start from the other long side and will ride to the opposite side of the riding-area. Both groups are riding with the same speed during this figure. The way of stretch for all shortline figures will start 1 metre from the long side of the riding-area until 1 metre before the opposite border of the riding-area.

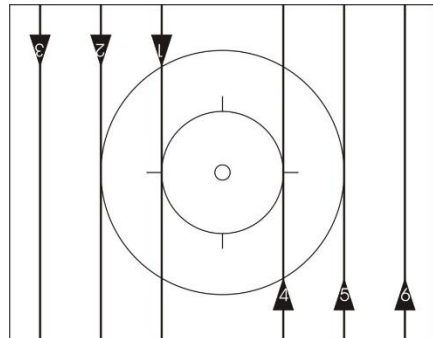

6039 a
6040 a
6041 a
6041 b

**3 next to each other shortline
opposite direction 6 single rings left**

Each 3 riders are riding as group next to each other without grip connection on an axis which runs parallel to the long side of the riding-area. The distance between rider 1 and 2 has to be identical with the distance between rider 2 and 3, between rider 4 and 5 and between rider 5 and 6. All riders are riding on an axis parallel to the short side of the riding-area. One group will start from the long side of the riding-area and ride to the opposite side of the riding-area. The other group will start from the other long side and will ride to the opposite side of the riding-area. Both groups are riding with the same speed during this figure.

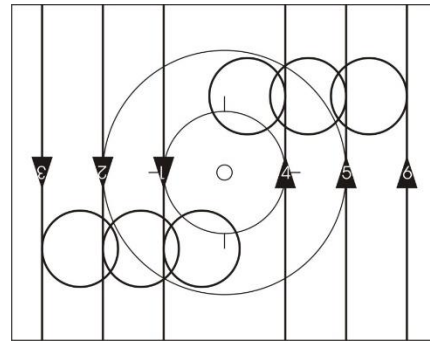

6039 b

During the figure, each rider performs simultaneously a same sized and uniform single ring left. The figure has to be performed 2 metre before and 2 metre after the single rings.

The way of stretch for all shortline figures will start 1 metre from the long side of the riding-area until 1 metre before the opposite border of the riding-area.

Single ring left (8.3.029)

**3 next to each other shortline
opposite direction through**

Each 3 riders are riding as group next to each other without grip connection on an axis which runs parallel to the long side of the riding-area. The distance between rider 1 and 2 has to be identical with the distance between rider 2 and 3, between rider 4 and 5 and between rider 5 and 6. All riders are riding on an axis parallel to the short side of the riding-area. One group will start from the long side of the riding-area and ride to the opposite side of the riding-area. The other group will start from the other long side and will ride to the opposite side of the riding-area. Both groups are riding with the same speed during this figure. Half way, at the middle of the riding-area, one rider of each group, will ride through the space between the two facing riders.

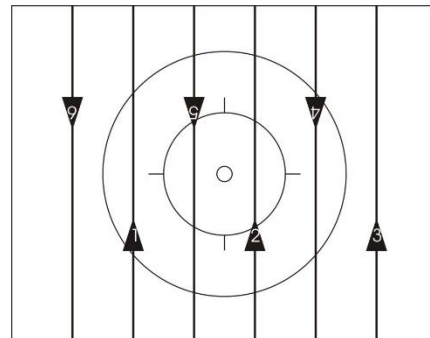

6039 c
6040 b
6041 c
6041 d

The way of stretch for all shortline figures will start 1 metre from the long side of the riding-area until 1 metre before the opposite border of the riding-area.

3 next to each other shortline opposite direction through 6 single rings left

Each 3 riders are riding next to each other without grip connection on an axis which runs parallel to the long side of the riding-area. The distance between rider 1 and 2 has to be identical with the distance between rider 2 and 3, between rider 4 and 5 and between rider 5 and 6. All riders

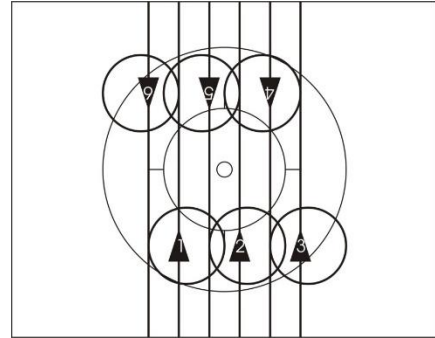

6039 d

are riding on an axis parallel to the short side of the riding-area. One group will start from the long side of the riding-area and ride to the opposite side of the riding-area. The other group will start from the other long side and will ride to the opposite side of the riding-area. Both groups are riding with the same speed during this figure. Half way, at the middle of the riding-area, two riders of each group, will ride through the space between the three facing riders. During the figure, each rider performs a single ring left simultaneously and uniform. The shortline has to be performed at least 2 metres before and 2 metres after the single ring left. The way of stretch for all shortline figures will start 1 metre from the long side of the riding-area until 1 metre distance before the opposite border of the riding-area.

Single ring left (8.3.029)

3 next to each other shortline opposite direction through 3 mills

6039 e

Each 3 riders are riding next to each other without grip connection on an axis which runs parallel to the long side of the riding-area. The distance between rider 1 and 2 has to be identical with the distance between rider 2 and 3, between rider 4 and 5 and between rider 5 and 6. All riders are riding on an axis parallel to the

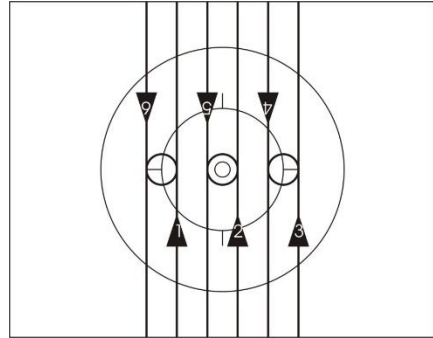

short side of the riding-area. One group will start from the long side of the riding-area and ride to the opposite side of the riding-area. The other group will start from the other long side and will ride to the opposite side of the riding-area. Both groups are riding with the same speed during this figure. Half way, at the middle of the riding-area, two riders of each group, will ride through the space between the three facing riders.

While passing the other group, each three riders are connecting their left hands to a mill simultaneously and in motion. Three mills have to be performed completely.

The way of stretch for all shortline figures will start at 1 metre distance from the long side of the riding-area until 1 metre distance before the opposite border of the riding-area.

Three Mills

Each two riders are riding at equal distances following each other around a spot on the riding-area. The used spots for the mills have the same distance to the centre of the riding-area and are situated on the longitudinal axis. The third spot is situated on the centre of the riding-area. Each rider of each group are building simultaneously a mill, with their left hands. The mills will start as soon as the grip connections are closed. Each 3 riders (one of each group) are riding on the same longitudinal axis during the figure. This axis runs parallel (with different distances) towards the long side of the riding-area during the whole way of stretch of the circle. The figure ends after a complete surrounding and reaching the starting position again.

3 next to each other shortline opposite direction half counter single ring

Each 3 riders are riding next to each other without grip connection on an axis which runs parallel to the long side of the riding-area. The distance between rider 1 and 2 has to be identical to the distance between rider 2 and 3, between rider 4 and 5 and between rider 5 and 6. Both groups of riders perform a half counter single ring. Both groups are riding with the same speed during this figure. One group will start from the long side of the riding-area and ride to the opposite side of the riding-area. The other group will start from the other long side and will ride to the opposite side of the riding-area.

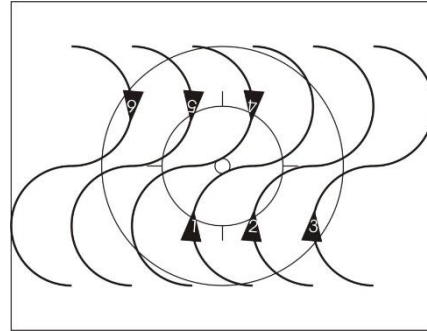

6039 f
6040 c
6042 a

Half counter single ring (8.3.031)

3 next to each other shortline opposite direction counter single ring

Each 3 riders are riding next to each other without grip connection on an axis which runs parallel to the long side of the riding-area. The distance between rider 1 and 2 has to be identical to the distance between rider 2 and 3, between rider 4 and 5 and between rider 5 and 6. Both groups of riders perform a counter single ring. Both groups are riding with the same speed during this figure. One group will start from the long side of the riding-area and ride to the opposite side of the riding-area. The other group will start from the other long side and will ride to the opposite side of the riding-area.

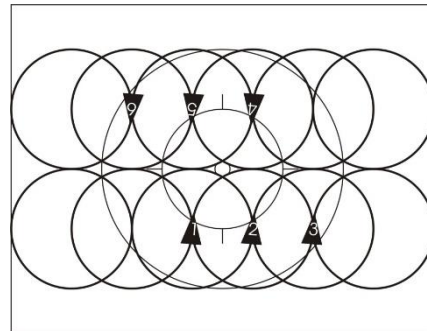

6039 g
6040 d
6042 b

Counter single ring (8.3.032)

2 following each other shortline

Each 3 riders are riding next to each other without grip connection. Rider 1, 2 and 3 and rider 4, 5 and 6 are riding as a group on the same axis which runs parallel to the long side of the riding-area. Rider 1 and 4, Rider 2 and 5 and Rider 3 and 6 are riding on the same axis parallel to the short side of the riding-area. The distance between the riders which are following each other may not be more than 2 metres. The way of stretch for all shortline figures will start 1 metre from the long side of the riding-area until 1 metre before of the opposite border of the riding-area.

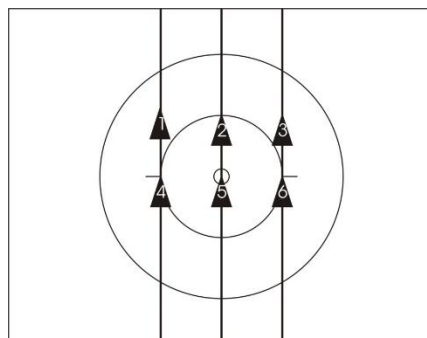

6052 a
6053 a

2 following each other shortline 6 single rings left

Each 3 riders are riding next to each other without grip connection. Rider 1, 2 and 3 and rider 4, 5 and 6 are riding as a group on the same axis which runs parallel to the long side of the riding-area. Rider 1 and 4, Rider 2 and 5 and Rider 3 and 6 are riding on the same axis parallel to the short side of the riding-area. The distance between the riders which are following each other may not be more than 2 metres. The way of stretch for all shortline figures will start 1 metre from the long side of the riding-area until 1 metre before of the opposite border of the riding-area.

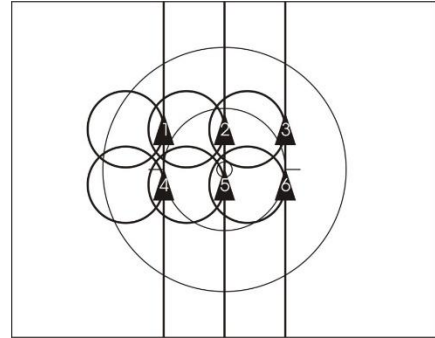

6052 b
6053 b

During the figure, each rider performs simultaneously a same sized and uniform single ring left. The way of stretch for all shortline figures will start 1 metre from the long side of the riding-area until 1 metre before of the opposite border of the riding-area.

Single ring left (8.3.029)

Triple circle

Each two riders following each other with same distances to each other while they are surrounding the same point on the riding-area. The centre of two points (one for each group) is situated with same distance to the centre of the riding-area on the longitudinal axis. One point is located on the centre of the riding-area. Each three riders (one of each group) are riding on the same longitudinal axis during the figure. The diameter of each circle of the triple circle must have at least a minimum of 4 metres. The different circles of the triple circle are overlapping. The figure ends when the point is rounded completely.

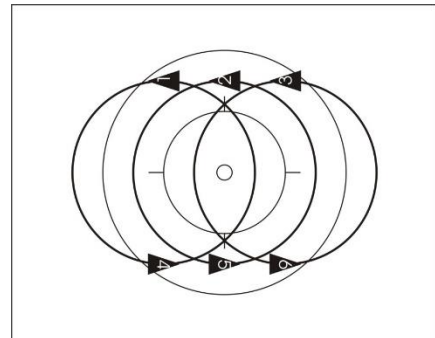

6061 a
6062 a
6063 a
6063 b
6064 a

2 connected half circle

Each two riders are riding side by side with grip connection they build a group of riders. The distance between rider 1 and 2 has to be identical to the distance between rider 3 and 4 and rider 5 and 6. All groups are riding with same distances to each other and with same distances to the 4-metre-circle outside of the 4-metre-circle.

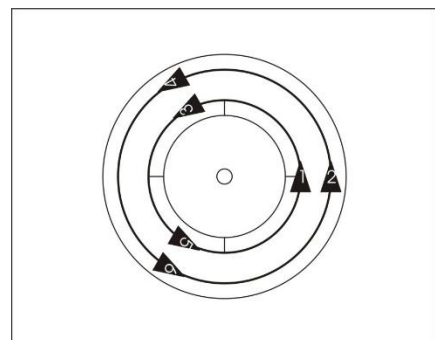

6081 a
6082 a
6083 a
6083 c
6084 a

The figure ends when the 4-metre-circle is rounded half.

2 connected circle

Each two riders are riding side by side with grip connection they build a group of riders. The distance between rider 1 and 2 has to be identical to the distance between rider 3 and 4 and rider 5 and 6. All groups are riding with same distances to each other and with same distances to the 4-metre-circle outside of the 4-metre-circle.

The figure ends when the 4-metre-circle is rounded completely.

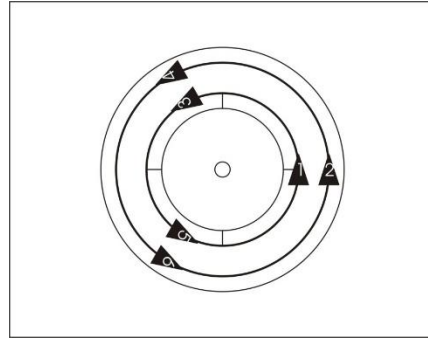

6081 b
6082 b
6083 b
6083 d

2 connected half circle 2 connected single rings left

Each two riders are riding side by side with grip connection they build a group of riders. The distance between rider 1 and 2 has to be identical to the distance between rider 3 and 4 and rider 5 and 6. All groups are riding with same distances to each other and with same distances to the 4-metre-circle outside of the 4-metre-circle.

During the figure the three groups of riders perform simultaneously and uniform a 2 connected single ring left.

The half circle has to be performed 2 metres before and 2 metres after the single ring left.

The figure ends when the 4-metre-circle is rounded half at the outside of the 4-metre-circle.

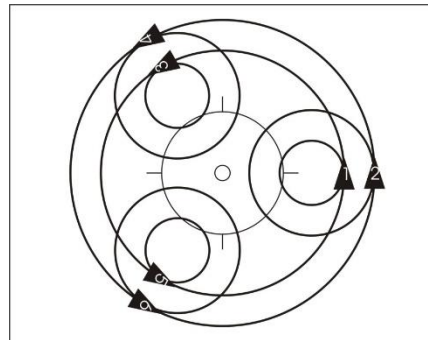

6081 c
6082 c
6083 e
6083 g

2 connected single ring left (8.3.033)

2 connected circle 2 connected single rings left

Each two riders are riding side by side with grip connection they build a group of riders. The distance between rider 1 and 2 has to be identical to the distance between rider 3 and 4 and rider 5 and 6. All groups are riding with same distances to each other and with same distances to the 4-metre-circle outside of the 4-metre-circle.

During the figure the three groups of riders perform simultaneously and uniform a 2 connected single ring left.

The circle has to be performed 2 metres before and 2 metres after the single ring left.

The figure ends when the 4-metre-circle is rounded completely at the outside of the 4-metre-circle.

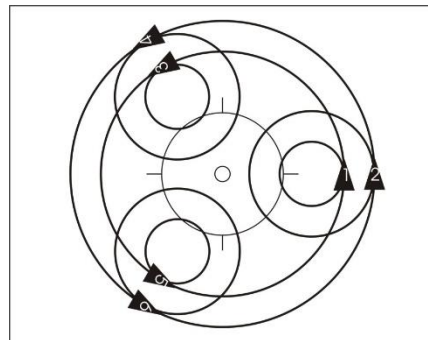

6081 d
6082 d
6083 f
6083 h

2 connected single ring left (8.3.033)

2 connected half circle 6 single rings left

Each two riders are riding side by side with grip connection they build a group of riders. The distance between rider 1 and 2 has to be identical to the distance between rider 3 and 4 and rider 5 and 6. All groups are riding with same distances to each other and with same distances to the 4-metre-circle outside of the 4-metre-circle.

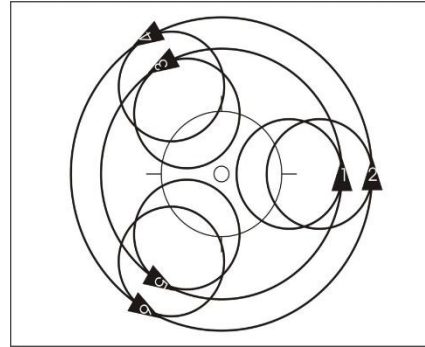

6081 e
6082 e
6083 i
6083 k
6084 e

During the figure, the grip connections have to be released simultaneously and in motion. Each rider performs a single ring left simultaneously and uniform. After the single rings left, the riders have to close the grip connections simultaneously and in motion.

The half circle has to be performed 2 metres before and 2 metres after the single ring left.

The figure ends when the 4-metre-circle is rounded half at the outside of the 4-metre-circle.

Single ring left (8.3.029)

2 connected circle 6 single rings left

Each two riders are riding side by side with grip connection they build a group of riders. The distance between rider 1 and 2 has to be identical to the distance between rider 3 and 4 and rider 5 and 6. All groups are riding with same distances to each other and with same distances to the 4-metre-circle outside of the 4-metre-circle.

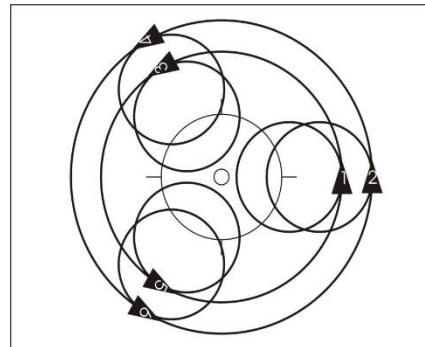

6081 f
6082 f
6083 j
6083 l
6084 f

During the figure, the grip connections have to be released simultaneously and in motion. Each rider performs a single ring left simultaneously and uniform. After the single rings left, the riders have to close the grip connections simultaneously and in motion.

The circle has to be performed 2 metres before and 2 metres after the single ring left.

The figure ends when the 4-metre-circle is rounded completely at the outside of the 4-metre-circle.

Single ring left (8.3.029)

**2 connected following each other
longline**

Each 2 riders are connected to each other with grip connection. The riders 1, 3 and 5 and the riders 2, 4 and 6 are riding on the same axis parallel to the long side of the riding-area. Rider 1 and 2, 3 and 4 and rider 5 and 6 are riding as groups on the same axis which runs parallel to the short side of the riding-area. The way of stretch for all longline figures will start 1 metre from the short side of the riding-area until 1 metre before of the opposite border of the riding-area.

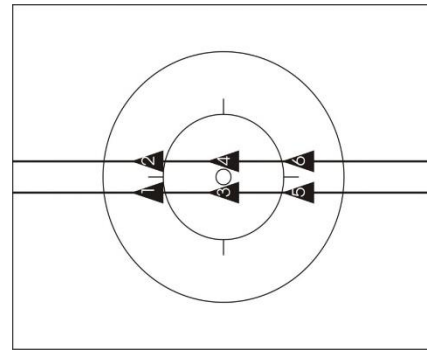

6092 a

**2 connected following each other
longline 3 single rings right 3 single
rings left**

Each 2 riders are connected to each other with grip connection. The riders 1, 3 and 5 and the riders 2, 4 and 6 are riding on the same axis parallel to the long side of the riding-area. Rider 1 and 2, 3 and 4 and rider 5 and 6 are riding as groups on the same axis which runs parallel to the short side of the riding-area.

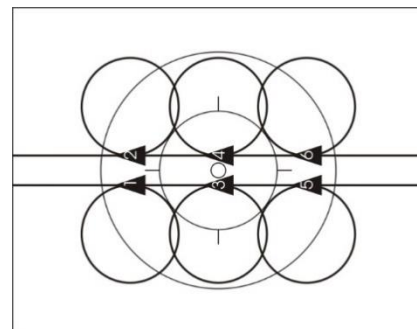

6092 b

During the figure the grip connections have to be released simultaneously and in motion. Rider 1, 3 and 5 perform a single ring single ring left and rider 2, 4 and 6 perform a single ring right simultaneously.

The single rings have to be performed with same size and uniform. After the single rings the riders have to close the grip connections simultaneously and in motion.

The longline has to be performed 2 metres before and 2 metres after the single rings.

The way of stretch for all longline figures will start 1 metre from the short side of the riding-area until 1 metre before of the opposite border of the riding-area.

Single ring left (8.3.029)

Single ring right (8.3.030)

2 connected shortline

Each 2 riders are connected to each other with grip connection, each rider is riding on an axis parallel to the short side of the riding-area. The distance between rider 1 and 2 has to be identical to the distance between rider 3 and 4 and to the distance between rider 5 and 6. All riders are riding on the same axis which runs parallel to the long side of the riding-area. The way of stretch for all short line exercises will start 1 metre from the **short long** side of the riding-area until 1 metre before the opposite border of the riding-area.

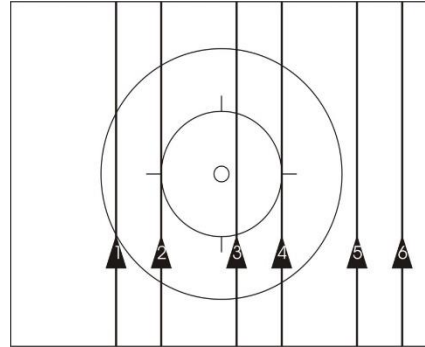

6096 a
6097 a
6098 a
6098 b
6099 a

2 connected shortline 2 connected single rings left

Each 2 riders are connected to each other with grip connection, each rider is riding on an axis parallel to the short side of the riding-area. The distance between rider 1 and 2 has to be identical to the distance between rider 3 and 4 and to the distance between rider 5 and 6. All riders are riding on the same axis which runs parallel to the long side of the riding-area.

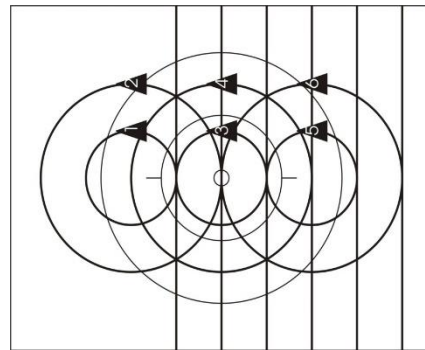

6096 b
6097 b
6098 c
6098 d
6099 b

During the figure each of the group has to perform simultaneously a 2 connected single ring left with same size and uniform. The shortline has to be performed 2 metres before and 2 metres after the single ring left. The way of stretch for all shortline figures will start 1 metre from the **short long** side of the riding-area until 1 metre before the opposite border of the riding-area.

2 connected single ring left (8.3.033)

2 connected shortline 2 connected single rings right

Each 2 riders are connected to each other by a grip connection, each rider is riding on an axis parallel to the short side of the riding-area. The distance between rider 1 and 2 must be identical to the distance between rider 3 and 4 and to the distance between rider 5 and 6. All riders are riding on the same axis which runs parallel to the long side of the riding-area.

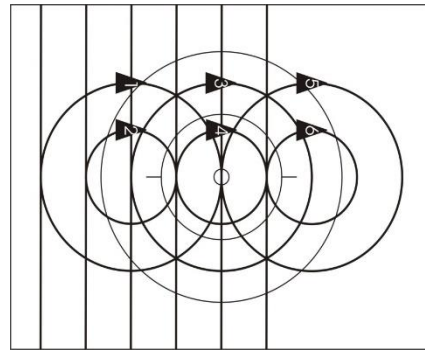

6096 c

During the figure each of the group has to perform simultaneously a 2 connected single ring right with same size and uniform.

The shortline has to be performed 2 metres before and 2 metres after the single ring right.

The way of stretch for all shortline figures will start 1 metre from the **short long** side of the riding-area until 1 metre before the opposite border of the riding-area.

2 connected single ring right (8.3.034)

2 connected shortline 6 single rings left

Each 2 riders are connected to each other by a grip connection, each rider is riding on an axis parallel to the short side of the riding-area. The distance between rider 1 and 2 must be identical to the distance between rider 3 and 4 and to the distance between rider 5 and 6. All riders are riding on the same axis which runs parallel to the long side of the riding-area.

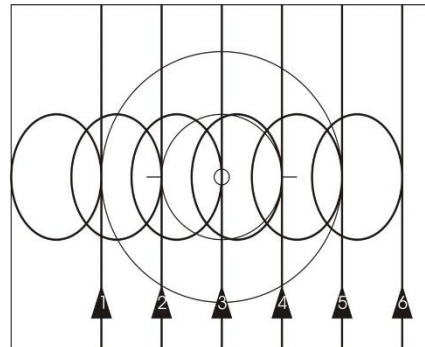

6096 d
6097 c
6098 e
6098 f
6099 c

During the figure, the grip connections have to be released simultaneously and in motion. Each rider performs a single ring left simultaneously and uniform.

After the single rings left, the riders have to close the grip connections simultaneously and in motion.

The shortline has to be performed 2 metres before and 2 metres after the single ring left.

The way of stretch for all shortline figures will start at 1 metre distance from the **short long** side of the riding-area until 1 metre before the opposite border of the riding-area.

Single ring left (8.3.029)

2 connected shortline half counter single ring

Each 2 riders are riding next to each other with grip connection. The distance between rider 1 and 2 must be identical to the distance between rider 3 and 4 and the distance between 5 and 6. All groups are on an axis which runs parallel to the long side of the riding-area. All groups of riders perform a half counter single ring.

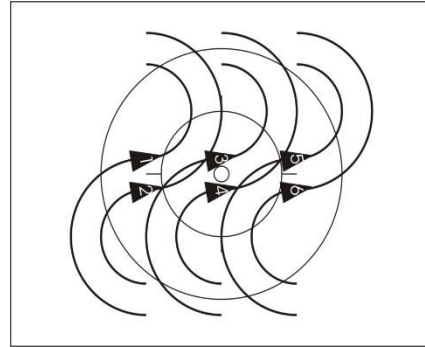

6106 a
6107 a
6108 a
6108 c
6109 a

Half counter single ring (8.3.031)

2 connected shortline counter single ring

Each 2 riders are riding as a group next to each other with grip connection. The distance between rider 1 and 2 must be identical to the distance between rider 3 and 4 and the distance between 5 and 6. All groups are on an axis which runs parallel to the long side of the riding-area. All groups of riders perform a counter single ring.

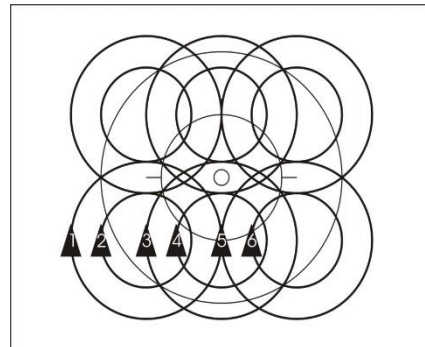

6106 b
6107 b
6108 b
6108 d
6109 b

Counter single ring (8.3.032)

Three Mills

Each 2 riders are riding at equal distances following each other around a spot at the riding-area. The used spots for the mills have the same distance to the centre of the riding-area and are situated on the longitudinal axis. The third spot is situated on the centre of the riding-area. All riders of each group are connected with their left hands. The mills will start when all riders are connected. Each 3 riders (one of each group) are riding on the same longitudinal axis during the figure. This axis runs parallel (with different distances) towards the long side of the riding-area during the whole way of stretch of the circle. The figure ends, when the point is rounded completely and the starting position is reached again.

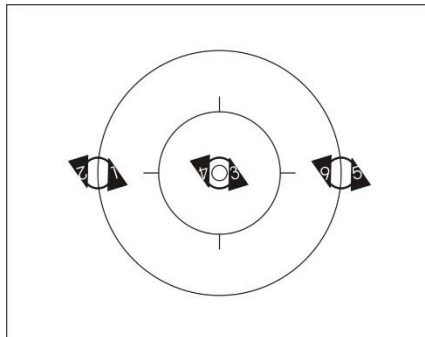

6121 a
6122 a
6122 b
6122 c
6123 a
6123 b
6123 c
6123 d
6123 e
6123 f
6124 a
6124 b
6124 c

Three inside rings

Each 2 riders are riding at equal distances following each other around a spot at the riding-area. Each rider of each group is connected with his right hand to the left hand of his partner. The used spots for the rings have the same distance to the centre of the riding-area and are situated on the longitudinal axis. The third spot is situated on the centre of the riding-area. The rings will start when all riders are connected. Each 3 riders (one of each group) are riding on the same longitudinal axis during the figure. This axis runs parallel towards the long side of the riding-area during the whole way of stretch.

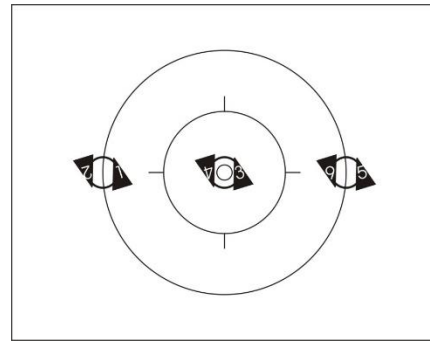

6133 a
6133 b
6133 c
6133 d
6133 e
6134 a
6134 b
6134 c

The figure ends, when the point is rounded completely and the starting position is reached again.

Three outside rings

Each two riders are riding at equal distances following each other around a spot on the riding-area. Each rider of each group is connected with his left hand to the right hand of his partner. The used spots for the rings are at the same distance from the centre of the riding-area and are situated on the longitudinal axis. The third spot is situated at the centre of the riding-area. The rings will start when all riders are connected. Each 3 riders (one of each group) are riding on the same longitudinal axis during the figure. This axis runs parallel towards the long side of the riding-area during the whole way of stretch.

6135 a
6135 b
6135 c
6135 d
6135 e
6136 a
6136 b
6136 c

The figure ends, when the point is completely rounded and that the riders have reached the starting position.

3 connected half circle

Three riders are riding side by side with grip connection they build a group. The distance between rider 1 and 2 has to be identical to the distance between rider 2 and 3, between rider 4 and 5 and between rider 5 and 6. Both groups are riding at same distances to each other and at same distance to the 4-metre-circle, at the outside of the 4-metre-circle.

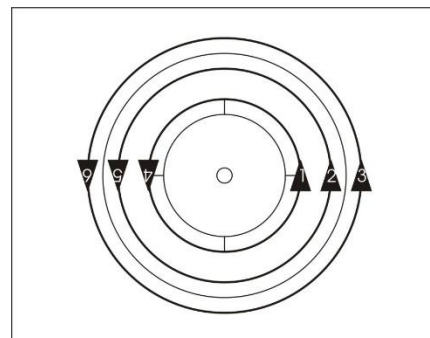

6151 a
6152 a
6153 a
6153 c
6154 a

The figure ends, when the 4-metre-circle is rounded half at the outside of the 4-metre-circle.

3 connected circle

Three riders are riding side by side with grip connection they build a group. The distance between rider 1 and 2 has to be identical to the distance between rider 2 and 3, between rider 4 and 5 and between rider 5 and 6. Both groups are riding at same distances to each other and at same distance to the 4-metre-circle, at the outside of the 4-metre-circle.

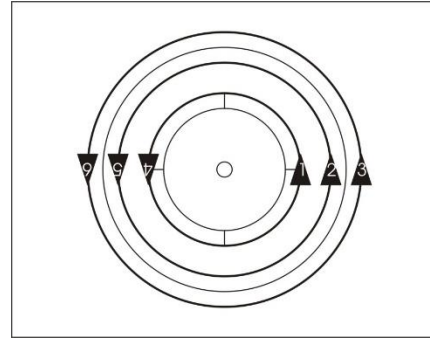

6151 b
6152 b
6153 b
6153 d
6154 b

The figure ends, when the 4-metre-circle is rounded completely at the outside of the 4-metre-circle.

3 connected half circle 6 single rings left

Three riders are riding side by side with grip connection they build a group. The distance between rider 1 and 2 has to be identical to the distance between rider 2 and 3, between rider 4 and 5 and between rider 5 and 6. Both groups are riding at same distances to each other and at same distance to the 4-metre-circle, at the outside of the 4-metre-circle.

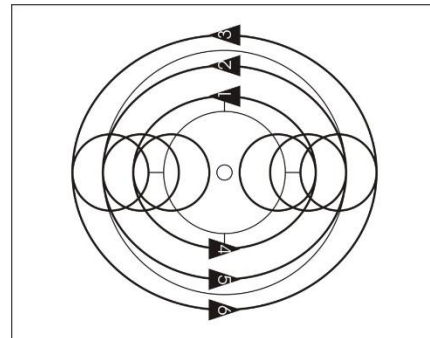

6151 c
6152 c
6153 e
6153 g
6154 c

During the figure, the grip connections have to be released simultaneously and in motion. Each rider performs simultaneously a single ring left with same size and uniform After the single rings left, the riders have to close the grip connections simultaneously and in motion.

The figure has to be performed 2 metres before and 2 metre after the single rings.

The figure ends when the 4-metre-circle is rounded half at the outside of the 4-metre-circle.

Single ring left (8.3.029)

3 connected circle 6 single rings left

Three riders are riding side by side with grip connection they build a group. The distance between rider 1 and 2 has to be identical to the distance between rider 2 and 3, between rider 4 and 5 and between rider 5 and 6. Both groups are riding at same distances to each other and at same distance to the 4-metre-circle, at the outside of the 4-metre-circle.

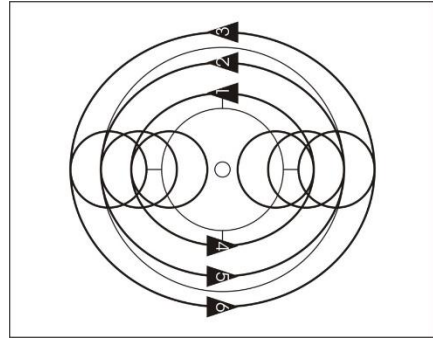

6151 d
6152 d
6153 f
6153 h
6154 d

During the figure, the grip connections have to be released simultaneously and in motion. Each rider performs a simultaneously a single ring left with the same size and uniform. After the single rings left, the riders have to restore the grip connections simultaneously and in motion.

The exercise has to be performed 2 metres before and 2 metres after the single rings.

The figure ends when the 4-metre-circle is rounded completely at the outside of the 4-metre-circle.

Single ring left (8.3.029)

3 connected shortline

Each 3 riders are connected to each other by a grip connection, each rider is riding on an axis parallel to the short side of the riding-area. 1 and 2 has to be identical to the distance between rider 2 and 3, between rider 4 and 5 and between rider 5 and 6. All riders are riding on the same axis which runs parallel to the long side of the riding-area. The way of stretch for all shortline figures will start 1 metre from the short side of the riding-area until 1 metre before the opposite border of the riding-area.

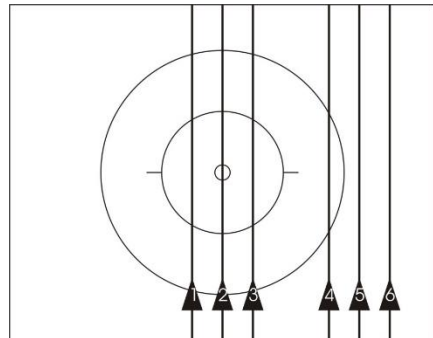

6165 a
6166 a
6167 a
6167 b
6168 a

3 connected shortline 6 single rings left

Each 3 riders are connected to each other by a grip connection, each rider is riding on an axis parallel to the short side of the riding-area. 1 and 2 has to be identical to the distance between rider 2 and 3, between rider 4 and 5 and between rider 5 and 6. All riders are riding on the same axis which runs parallel to the long side of the riding-area. During the figure, the grip connections have to be released simultaneously and in motion. Each rider performs simultaneously a single ring left with same size and uniform. After the single rings left, the riders have to close the grip connections simultaneously and in motion. The shortline has to be performed 2 metres before and 2 metres after the single ring left. The way of stretch for all shortline figures will start at 1 metre distance from the short side of the riding-area until 1 metre before the opposite border of the riding-area.

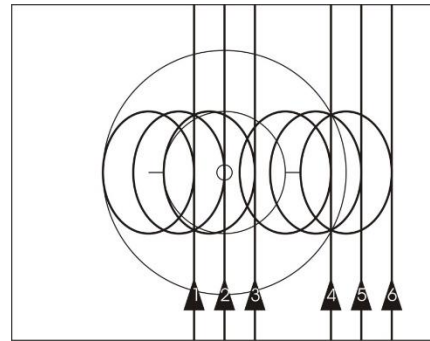

6165 b
6166 b
6167 c
6167 d
6168 b

Single ring left (8.3.029)

3 connected shortline opposite direction

Each 3 riders are connected to each other by a grip connection, each rider is riding on an axis parallel to the short side of the riding-area. 1 and 2 has to be identical to the distance between rider 2 and 3, between rider 4 and 5 and between rider 5 and 6. All riders are riding on the same axis which runs parallel to the long side of the riding-area. One group will start from the long side of the riding-area and ride to the opposite side of the riding-area. The other group will start from the other long side and will ride to the opposite side of the riding-area. Both groups are riding with the same speed during this figure. The way of stretch for all shortline figures will start 1 metre from the short side of the riding-area until 1 metre before the opposite border of the riding-area.

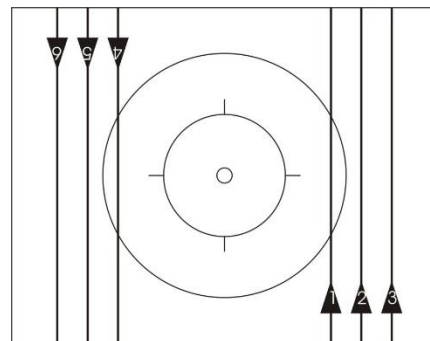

6170 a
6171 a
6172 a
6172 b
6173 a

3 connected shortline opposite 6 single rings left

Each 3 riders are connected to each other by a grip connection, each rider is riding on an axis parallel to the short side of the riding-area. 1 and 2 has to be identical to the distance between rider 2 and 3, between rider 4 and 5 and between rider 5 and 6. All riders are riding on the same axis which runs parallel to the long side of the riding-area. One group will start from the long side of the riding-area and ride to the opposite side of the riding-area. The other group will start from the other long side and will ride to the opposite side of the riding-area. Both groups are riding with the same speed during this figure. During the figure, the grip connections have to be released simultaneously and in motion. Each rider performs simultaneously a single ring left with same size and uniform. After the single rings left, the riders have to close the grip connections simultaneously and in motion. The shortline has to be performed 2 metres before and 2 metres after the single ring left. The way of stretch for all shortline figures will start at 1 metre distance from the short side of the riding-area until 1 metre before the opposite border of the riding-area.

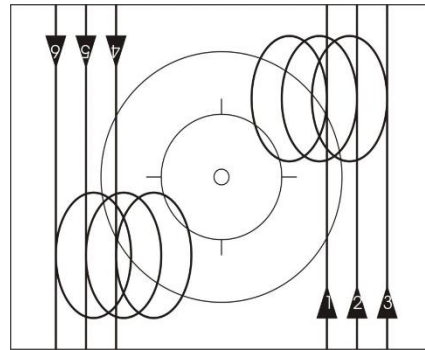

6170 b
6171 b
6172 c
6172 d
6173 b

Single ring left (8.3.029)

2 connected around 1

Three riders are riding side by side with grip connection they build a group of riders. The two groups are riding on the same, imaginary axis, through the middle of riding-area.

The inside riders are standing on a spot (without pedalling), while the other two riders are riding next to each other on one line, a complete circle around the inside rider. The distance between rider 1 and 2 has to be identical to the distance between riders 4 and 5. The distance between rider 2 and 3 has to be identical to the distance between riders 5 and 6.

The figure ends after completing the way of stretch of a complete circle.

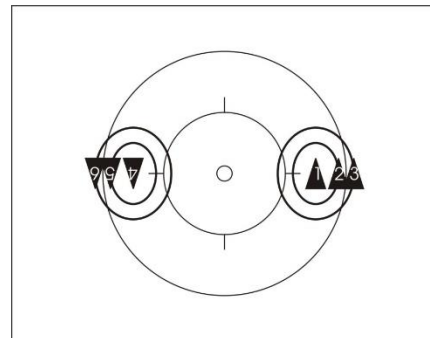

6186 a
6187 a

Two chains half circle

Three riders each are riding around the 4 metre circle in left-right position.

Rider 2 and 5 are connected with their left hands to the right shoulders of rider 1 and 4. Rider 3 and 6 are connected with their right hands to the left shoulders of rider 2 and 5.

The figure ends when the 4-metre-circle is rounded half at the outside of the 4-metre-circle.

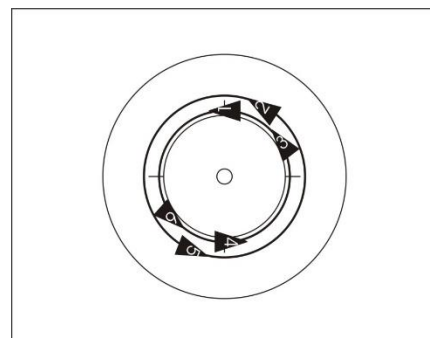

6196 a

Two chains circle

Three riders each are riding around the 4 metre circle in left-right position. Rider 2 and 5 are connected with their left hands to the right shoulders of rider 1 and 4. Rider 3 and 6 are connected with their right hands to the left shoulders of rider 2 and 5. The figure ends when the 4-metre-circle is rounded completely at the outside of the 4-metre-circle.

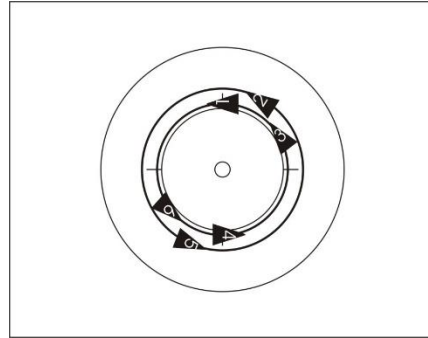

6196 b

Two chains half circle raiser

Three riders each are riding around the 4 metre circle in left-right position. Both groups are riding at same distances to each other and at same distance to the 4-metre-circle, at the outside of the 4-metre-circle. Rider 1 is connected with the right hand to the right hand of rider 2. Rider 2 is connected with the left hand to the right hand of rider 3. Rider 4 is connected with his right hand to the right hand of rider 5. Rider 5 is connected with his left hand to the right hand of rider 6. The figure ends when the 4-metre-circle is rounded half at the outside of the 4-metre-circle.

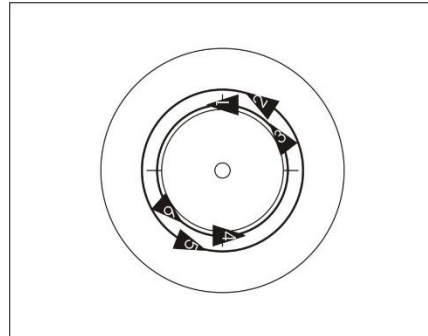

6197 a
6197 c

Two chains circle raiser

Three riders each are riding around the 4 metre circle in left-right position. Both groups are riding at same distances to each other and at same distance to the 4-metre-circle, at the outside of the 4-metre-circle. Rider 1 is connected with the right hand to the right hand of rider 2. Rider 2 is connected with the left hand to the right hand of rider 3. Rider 4 is connected with his right hand to the right hand of rider 5. Rider 5 is connected with his left hand to the right hand of rider 6. The figure ends when the 4-metre-circle is rounded completely at the outside of the 4-metre-circle.

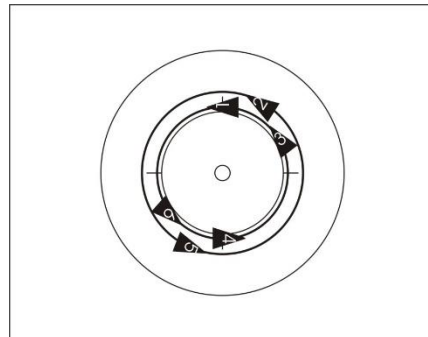

6197 b
6197 d

Two saddle-grip half circle

Three riders each are riding around the 4 metre circle in left-right position. Both groups are riding at same distances to each other and at same distance to the 4-metre-circle, at the outside of the 4-metre-circle.

Rider 1 is connected with both hands to his own bicycle handlebar. Rider 2 is connected with his left hand to the saddle of rider 1. Rider 3 is connected with his left hand to the saddle of rider 2. Rider 4 is connected with both hands to his own bicycle handlebar. Rider 5 is connected with his left hand to the saddle of rider 4. Rider 6 is connected with his left hand to the saddle of rider 5.

The figure ends when the 4-metre-circle is rounded half at the outside of the 4-metre-circle.

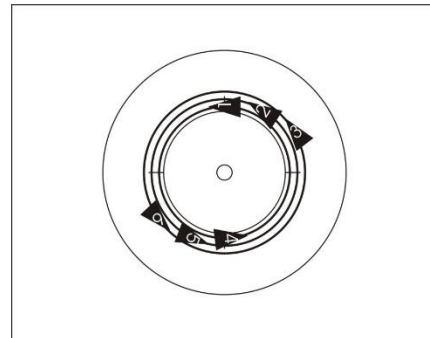

6201 a

Two saddle-grip circle

Three riders each are riding around the 4 metre circle in left-right position. Both groups are riding at same distances to each other and at same distance to the 4-metre-circle, at the outside of the 4-metre-circle.

Rider 1 is connected with both hands to his own bicycle handlebar. Rider 2 is connected with his left hand to the saddle of rider 1. Rider 3 is connected with his left hand to the saddle of rider 2. Rider 4 is connected with both hands to his own bicycle handlebar. Rider 5 is connected with his left hand to the saddle of rider 4. Rider 6 is connected with his left hand to the saddle of rider 5.

The figure ends when the 4-metre-circle is rounded completely at the outside of the 4-metre-circle.

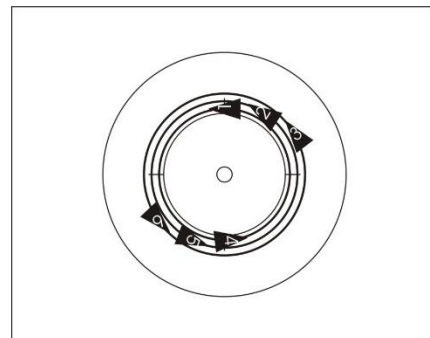

6201 b

Two Turbines

Three riders are next to each other on an axis around a spot at the riding-area and are connected by hand-in-hand grip connection. The central rider is standing on this spot without pedalling. The used spots for the turbines have the same distance to the centre of the riding-area and are situated on the longitudinal axis. The two outside riders are riding in the same direction around the central rider and will turn the rider on the spot; performing a turbine.

Each rider (one of each group) are riding on the same longitudinal axis during the figure. This axis runs parallel towards the long side of the riding-area during the whole way of stretch of the circle.

The figure is finished if the starting position is reached.

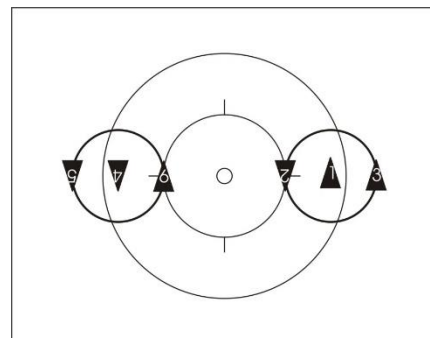

6208 a
6208 b
6208 c
6208 d
6208 e
6208 f
6209 a
6209 b
6209 c

Two Turbines 3 spinnings

Three riders are next to each other on an axis around a spot at the riding-area and are connected by hand-in-hand grip connection. The central rider is standing on this spot without pedalling. The used spots for the turbines have the same distance to the centre of the riding-area and are situated on the longitudinal axis. The two outside riders are riding in the same direction around the central rider and will turn the rider on the spot; performing a turbine.

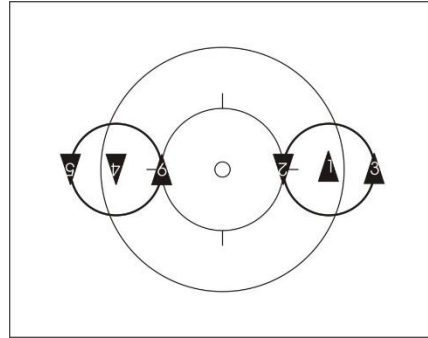

6209 d

Each rider (one of each group) are riding on the same longitudinal axis during the figure. This axis runs parallel towards the long side of the riding-area during the whole way of stretch of the circle.

During the figure, the grip connections have to be released simultaneously and in motion and the two central riders have to perform three spinnings simultaneously.

After the spinnings the grip connections have to be closed simultaneously and in motion. The Turbine has to be performed 2 metres before and 2 metres after the spinnings.

The figure ends when after a complete surrounding the starting position is reached.

Spinnings (8.3.037)

Two Mills

Each three riders are riding at equal distances following each other around a spot at the riding-area. They are connected with their left hands. The used spots for the mills have the same distances to the centre of the riding-area and are situated on the longitudinal axis. The mills will start at when all grip connections are closed. Each 2 riders (one of each group) are riding on the same longitudinal axis during the figure. This axis runs parallel towards the long side of the riding-area during the whole way of stretch of the circle. The figure ends after a complete surrounding when the starting position is reached.

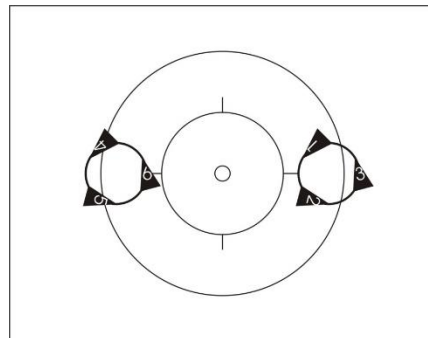

- 6216 a
- 6217 a
- 6217 b
- 6217 c
- 6218 a
- 6218 b
- 6218 c
- 6218 d
- 6218 e
- 6218 f
- 6219 a
- 6219 b
- 6219 c

Two inside rings

Each three riders are riding at equal distances following each other around a spot at the riding-area. The used spots for the rings have the same distance to the centre of the riding-area and are situated on the longitudinal axis. Each rider of each group grabs with his right hand the left hand of the rider in front of him. Both rings will start when all grip connections are closed. Each 2 riders (one of each group) are riding on the same longitudinal axis during the figure. This axis runs parallel towards the long side of the riding-area during the whole way of stretch of the circle. The figure ends after a complete surrounding when the starting position is reached.

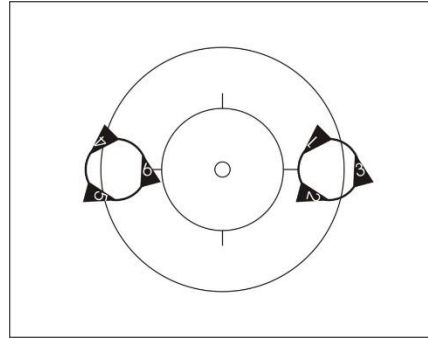

6228 a
6228 b
6228 c
6228 d
6228 e
6229 a
6229 b
6229 c

Two outside rings

Each three riders are riding at equal distances following each other around a spot at the riding-area. The used spots for the rings have the same distance to the centre of the riding-area and are situated on the longitudinal axis. Each rider of each group grabs with his left hand the right hand of the rider in front of him. Both rings will start when all grip connections are closed. Each 2 riders (one of each group) are riding on the same longitudinal axis during the figure. This axis runs parallel towards the long side of the riding-area during the whole way of stretch of the circle. The figure ends after a complete surrounding when the starting position is reached.

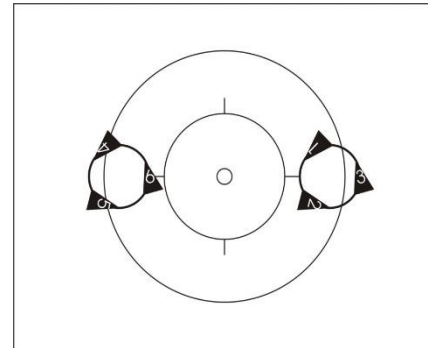

6236 a
6236 b
6236 c
6236 d
6236 e
6237 a
6237 b
6237 c

Two outside rings half surrounding followed by two inside rings half surrounding

The starting position are two outside rings. After at least a half surrounding the riders change into two inside rings. Releasing the grip connections of the outside rings into the inside rings have to occur simultaneously and in motion. The figure ends after the way of stretch of a half circle inside ring is performed.

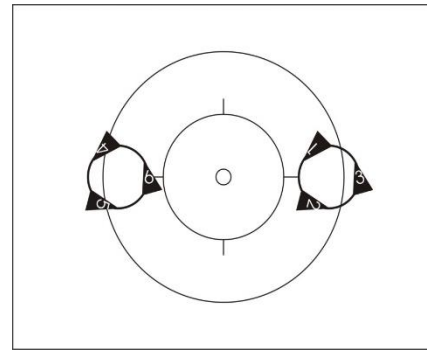

6236 f
6237 d

Two outside rings

Each three riders are riding at equal distances following each other around a spot at the riding-area. The used spots for the rings have the same distance to the centre of the riding-area and are situated on the longitudinal axis. Each rider of each group grabs with his left hand the right hand of the rider in front of him. Both rings will start when all grip connections are closed. Each 2 riders (one of each group) are riding on the same longitudinal axis during the figure. This axis runs parallel towards the long side of the riding-area during the whole way of stretch of the circle. The figure ends after a complete surrounding when the starting position is reached.

Two inside rings

Each three riders are riding at equal distances following each other around a spot at the riding-area. The used spots for the rings have the same distance to the centre of the riding-area and are situated on the longitudinal axis. Each rider of each group grabs with his right hand the left hand of the rider in front of him. Both rings will start when all grip connections are closed. Each 2 riders (one of each group) are riding on the same longitudinal axis during the figure. This axis runs parallel towards the long side of the riding-area during the whole way of stretch of the circle. The figure ends after a complete surrounding when the starting position is reached.

Two stars outside

Three riders each are connected and standing without moving around a common spot. The rear wheels of the bikes show in direction of a point which is situated with same distance to the centre of the riding-area and on the longitudinal axis.

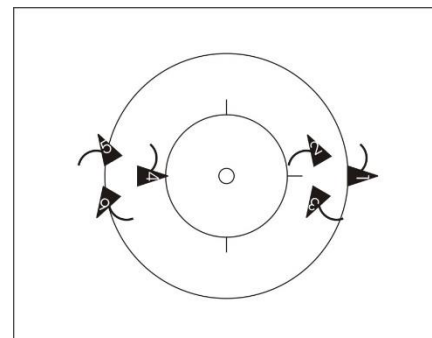

6251 a
6252 a

6 connected half circle

All riders are riding with grip connection side by side on an axis, which goes through the center of the riding-area, around the 4-metre-circle. The distance between rider 1 and 2 has to be identical to the distance between riders 2 and 3, between riders 3 and 4, between riders 4 and 5 and between riders 5 and 6. In maximum two riders are allowed to ride within the 4-metre-circle.

The figure ends when the 4-metre-circle is rounded half at the outside of the 4-metre-circle.

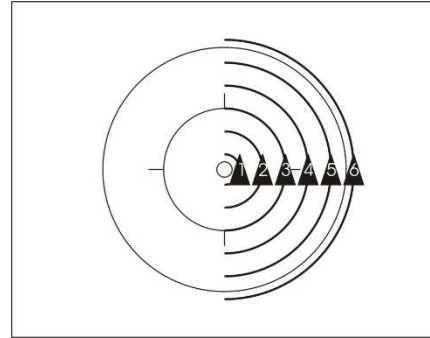

6271 a
6272 a
6273 a
6273 c
6274 a

6 connected circle

All riders are riding with grip connection side by side on an axis, which goes through the center of the riding-area, around the 4-metre-circle. The distance between rider 1 and 2 has to be identical to the distance between riders 2 and 3, between riders 3 and 4, between riders 4 and 5 and between riders 5 and 6. In maximum two riders are allowed to ride within the 4-metre-circle.

The figure ends when the 4-metre-circle is rounded at the outside of the 4-metre-circle.

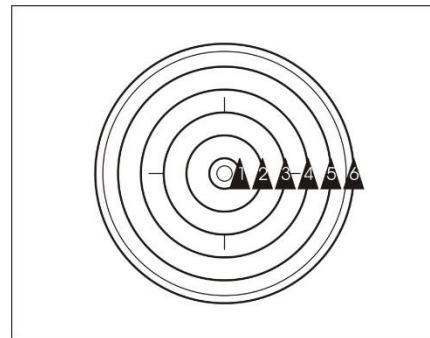

6271 b
6272 b
6273 b
6273 d
6274 b

6 connected half circle 2 connected single rings left

All riders are riding with grip connection side by side on an axis, which goes through the center of the riding-area, around the 4-metre-circle. The distance between rider 1 and 2 has to be identical to the distance between riders 2 and 3, between riders 3 and 4, between riders 4 and 5 and between riders 5 and 6. In maximum two riders are allowed to ride within the 4-metre-circle. During the figure the grip connections between rider 2 and 3 and rider 4 and 5 have to be released. The three groups of riders perform a 2 connected single ring left simultaneously and uniform. The half circle has to be performed 2 metres before and 2 metres after the single ring left.

The figure ends when the 4-metre-circle is rounded half at the outside of the 4-metre-circle.

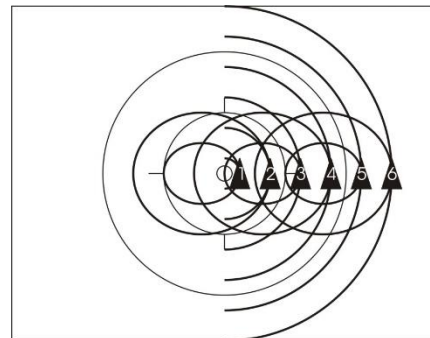

6271 c
6272 c
6273 e
6273 g
6274 c

2 connected single ring left (8.3.033)

6 connected circle 2 connected single rings left

All riders are riding with grip connection side by side on an axis, which goes through the center of the riding-area, around the 4-metre-circle. The distance between rider 1 and 2 has to be identical to the distance between riders 2 and 3, between riders 3 and 4, between riders 4 and 5 and between riders 5 and 6. In maximum two riders are allowed to ride within the 4-metre-circle.

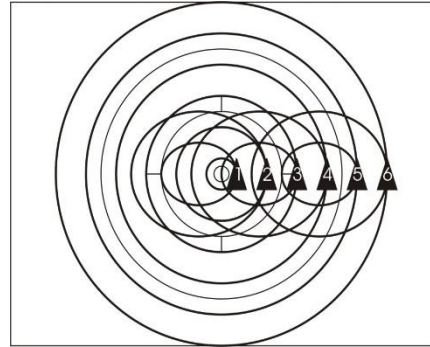

6271 d
6272 d
6273 f
6273 h
6274 d

During the figure the grip connections between rider 2 and 3 and rider 4 and 5 have to be released. The three groups of riders perform a 2 connected single ring left simultaneously and uniform. The circle has to be performed 2 metres before and 2 metres after the single ring left.

The figure ends when the 4-metre-circle is rounded completely at the outside of the 4-metre-circle.

2 connected single ring left (8.3.033)

6 connected half circle 6 single rings left

All riders are riding with grip connection side by side on an axis, which goes through the center of the riding-area, around the 4-metre-circle. The distance between rider 1 and 2 has to be identical to the distance between riders 2 and 3, between riders 3 and 4, between riders 4 and 5 and between riders 5 and 6. In maximum two riders are allowed to ride within the 4-metre-circle.

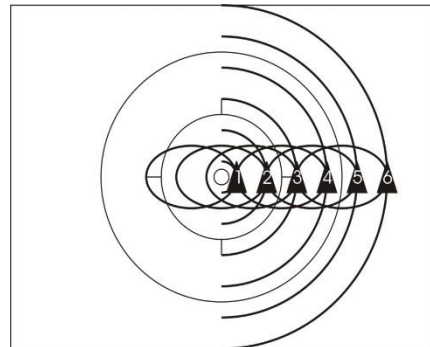

6271 e
6272 e
6273 i
6273 k
6274 e

During the figure, the grip connections have to be released simultaneously and in motion and all riders have to perform a single ring left simultaneously and uniform. After the single rings left, the riders have to close the grip connections simultaneously and in motion. The half circle has to be performed 2 metres before and 2 metres after the single rings left.

The figure ends when the 4-metre-circle is rounded half at the outside of the 4-metre-circle.

Single ring left (8.3.029)

6 connected circle 6 single rings left

All riders are riding with grip connection side by side on an axis, which goes through the center of the riding-area, around the 4-metre-circle. The distance between rider 1 and 2 has to be identical to the distance between riders 2 and 3, between riders 3 and 4, between riders 4 and 5 and between riders 5 and 6. In maximum two riders are allowed to ride within the 4-metre-circle. During the figure, the grip connections have to be released simultaneously and in motion and all riders have to perform a single ring left simultaneously and uniform. After the single rings left, the riders have to close the grip connections simultaneously and in motion. The half circle has to be performed 2 metres before and 2 metres after the single rings left. The figure ends when the 4-metre-circle is rounded completely at the outside of the 4-metre-circle.

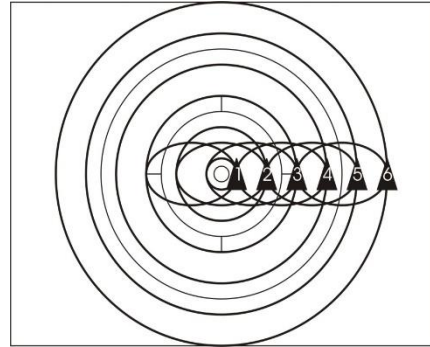

6271 f
6272 f
6273 j
6273 l
6274 f

Single ring left (8.3.029)

6 connected shortline

All riders are connected to each other with grip connection and are riding on the same axis parallel to the short side of the riding-area. The distances between rider 1 and 2 has to be identical to the distance between riders 2 and 3, between riders 3 and 4, between riders 4 and 5 and between riders 5 and 6. The way of stretch for all shortline figures will start 1 metre from the short side of the riding-area until 1 metre before the opposite border of the riding-area.

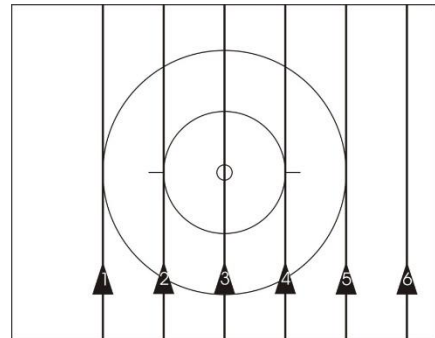

6281 a
6282 a
6283 a
6283 b
6284 a

6 connected shortline 2 connected single rings left

All riders are connected to each other with grip connection and are riding on the same axis parallel to the short side of the riding-area. The distances between rider 1 and 2 has to be identical to the distance between riders 2 and 3, between riders 3 and 4, between riders 4 and 5 and between riders 5 and 6. During the figure the grip connection between rider 2 and rider 3 and between rider 4 and 5 have to be released simultaneously and in motion.

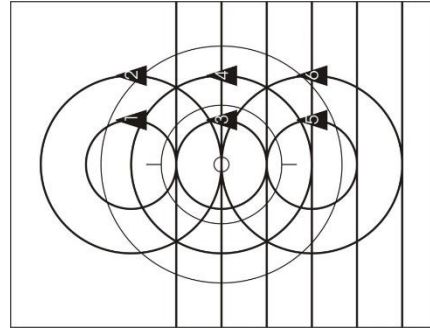

6281 b
6282 b
6283 c
6283 d
6284 b

The three groups of riders have to perform simultaneously a 2 connected single ring left with same size and uniform.

After the single rings the riders have to close the grip connection simultaneously and in motion.

The way of stretch for all shortline figures will start 1 metre from the short side of the riding-area until 1 metre before the opposite border of the riding-area.

2 connected single ring left (8.3.033)

6 connected shortline 6 single rings left

All riders are connected to each other with grip connection and are riding on the same axis parallel to the short side of the riding-area. The distances between rider 1 and 2 has to be identical to the distance between riders 2 and 3, between riders 3 and 4, between riders 4 and 5 and between riders 5 and 6. During the figure, the grip connections have to be released simultaneously and in motion and all riders have to perform a single ring left simultaneously and uniform. After the single rings left, the riders have to close the grip connections simultaneously and in motion.

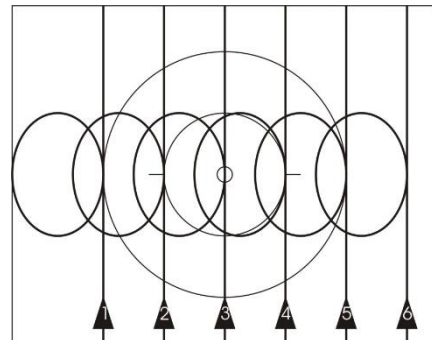

6281 c
6282 c
6283 e
6283 f
6284 c

The shortline has to be performed 2 metres before and 2 metres after the single rings left.

The way of stretch for all shortline figures will start 1 metre from the short side of the riding-area until 1 metre before the opposite border of the riding-area.

The way of stretch for all shortline figures will start 1 metre from the short side of the riding-area until 1 metre before the opposite border of the riding-area.

Single ring left (8.3.029)

6 next to each other shortline half counter single ring

All riders are riding next to each other without grip connection on an axis which runs parallel to the long side of the riding-area. The distance between rider 1 and 2 must be identical to the distance between rider 2 and 3 to the distance between rider 3 and 4 to the distance between rider 4 and 5 and to the distance between rider 5 and 6. All riders perform a half counter single ring.

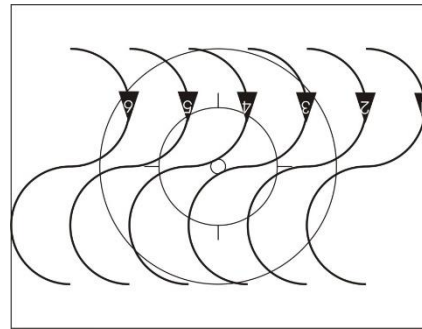

6281 d
6284 d

Half counter single ring (8.3.031)

6 next to each other shortline counter single ring

All riders are riding next to each other without grip connection on an axis which moves parallel to the long side of the riding-area. The distance between rider 1 and 2 must be identical to the distance between rider 2 and 3 to the distance between rider 3 and 4 to the distance between rider 4 and 5 and to the distance between rider 5 and 6. All riders perform a counter single ring.

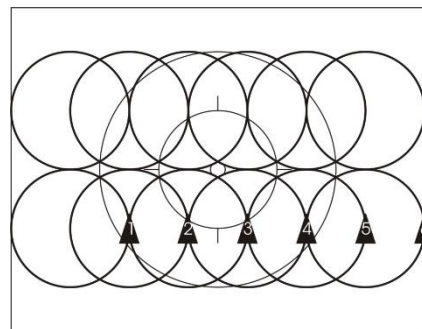

6281 e
6284 e

Counter single ring (8.3.032)

Surrounding 5 around 1

All riders are riding next to each other with grip connection.

The inside rider is standing on a spot (without pedaling), while the other five riders are riding next to each other, in one line, a complete circle around the inside rider. The distance between rider 2 and 3 has to be identical to the distance between rider 3 and 4, between rider 4 and 5 and between rider 5 and 6.

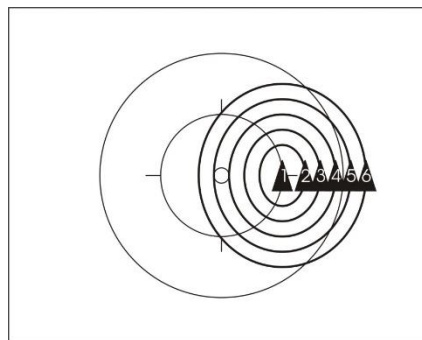

6291 a
6292 a
6293 a
6293 b
6294 a

The figure ends after completing surrounding around the inside rider.

Coach half circle

All riders are riding around the 4-metre-circle.

Rider 1 is connected with his right hand to the left bicycle handlebar-grip of rider 2. Rider 2 is grabs with his left hand backward to the right shoulder of rider 3. Rider 3 grabs with his left hand, to the right shoulder of rider 4. Rider 4 grabs with his left hand towards to the right shoulder of rider 5. Rider 5 grabs with his right hand towards to the left shoulder of rider 6. Rider 6 grabs with the right hand to the shoulder of rider 1. The figure ends when the 4-metre-circle is rounded half at the outside of the 4-metre-circle.

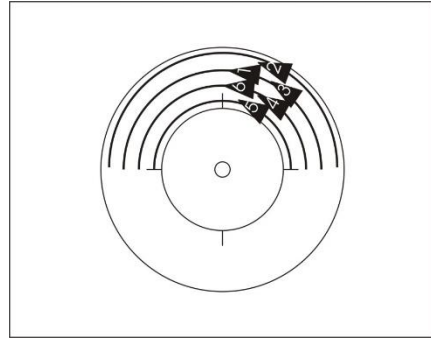

6301 a

Coach circle

All riders are riding around the 4-metre-circle.

Rider 1 is connected with his right hand to the left bicycle handlebar-grip of rider 2. Rider 2 is grabs with his left hand backward to the right shoulder of rider 3. Rider 3 grabs with his left hand, to the right shoulder of rider 4. Rider 4 grabs with his left hand towards to the right shoulder of rider 5. Rider 5 grabs with his right hand towards to the left shoulder of rider 6. Rider 6 grabs with the right hand to the shoulder of rider 1. The figure ends when the 4-metre-circle is rounded completely at the outside of the 4-metre-circle.

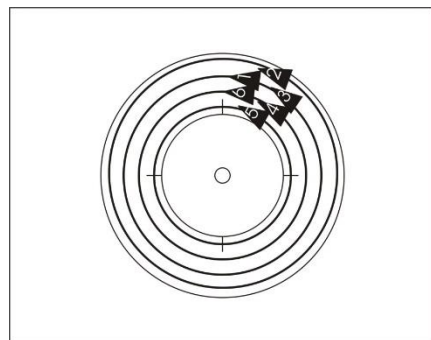

6301 b

Coach half circle raiser

All riders are riding around the 4-metre-circle

Rider 1 grabs with his right hand the right hand of rider 2. Rider 2 grabs with his left Hand the right hand of rider 3. Rider 3 grabs with his left hand the right hand of rider 4. Rider 4 grabs with his left hand the right hand of rider 5. Rider 5 grabs with his left hand the left hand of rider 6. Rider 6 grabs with his right hand the left hand of rider 1. The figure ends when the 4-metre-circle is rounded half at the outside of the 4-metre-circle.

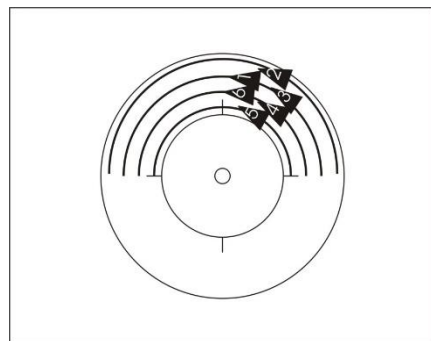

6302 a

Coach circle raiser

All riders are riding around the 4-metre-circle

Rider 1 grabs with his right hand the right hand of rider 2. Rider 2 grabs with his left Hand the right hand of rider 3. Rider 3 grabs with his left hand the right hand of rider 4. Rider 4 grabs with his left hand the right hand of rider 5. Rider 5 grabs with his left hand the left hand of rider 6. Rider 6 grabs with his right hand the left hand of rider 1.

The figure ends when the 4-metre-circle is rounded completely at the outside of the 4-metre-circle.

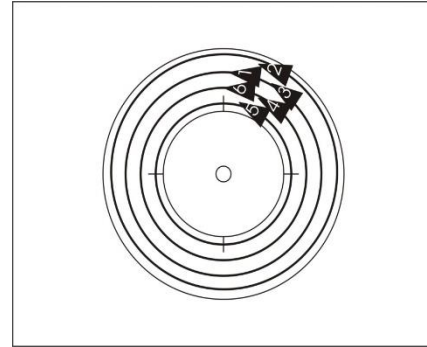

6302 b

Snake half circle

All riders are riding around the 4-metre circle in left-right position.

Rider 1 grabs with his right hand to the Handlebar of rider 2. Rider 2 grabs with his left hand to the handlebar of rider 3.

Rider 3 grabs with his right hand to the handlebar of rider 4. Rider 4 grabs with his left Hand to the handlebar of rider 5.

Rider 5 grabs with his right hand to the handlebar of rider 6. Rider 6 grabs with both hands to his own handlebar.

The figure ends when the 4-metre-circle is rounded half at the outside of the 4-metre-circle.

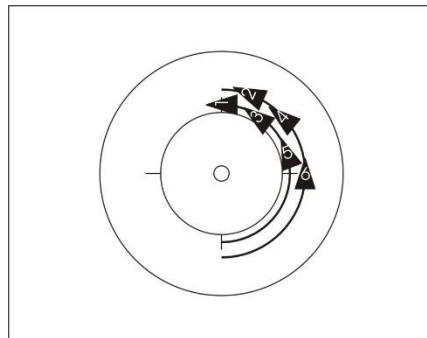

6311 a

Snake Circle

All riders are riding around the 4-metre circle in left-right position.

Rider 1 grabs with his right hand to the Handlebar of rider 2. Rider 2 grabs with his left hand to the handlebar of rider 3.

Rider 3 grabs with his right hand to the handlebar of rider 4. Rider 4 grabs with his left Hand to the handlebar of rider 5.

Rider 5 grabs with his right hand to the handlebar of rider 6. Rider 6 grabs with both hands to his own handlebar.

The figure ends when the 4-metre-circle is rounded completely at the outside of the 4-metre-circle.

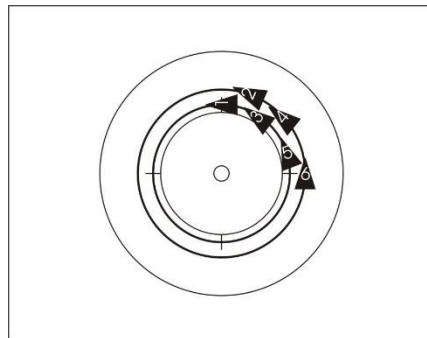

6311 b

Chain half circle

All riders are riding around the 4-metre-circle in left-right position.

Rider 1 grabs with both hands his handlebar. Rider 2 grabs with his left hand to the right shoulder of rider 1. Rider 3 grabs with his right hand to the left shoulder of rider 2. Rider 4 grabs with his left hand to the right shoulder of rider 3. Rider 5 grabs with his right hand to the left shoulder of rider 4. Rider 6 grabs with his left hand to the right shoulder of rider 5.

The figure ends when the 4-metre-circle is rounded half at the outside of the 4-metre-circle.

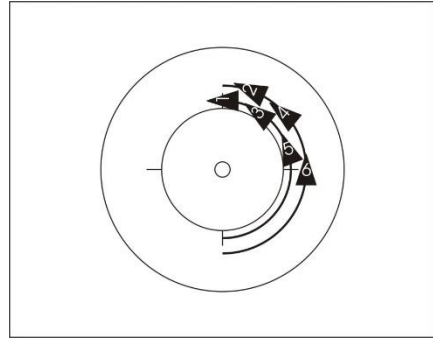

6316 a

Chain Circle

All riders are riding around the 4-metre-circle in left-right position.

Rider 1 grabs with both hands his handlebar. Rider 2 grabs with his left hand to the right shoulder of rider 1. Rider 3 grabs with his right hand to the left shoulder of rider 2. Rider 4 grabs with his left hand to the right shoulder of rider 3. Rider 5 grabs with his right hand to the left shoulder of rider 4. Rider 6 grabs with his left hand to the right shoulder of rider 5.

The figure ends when the 4-metre-circle is rounded completely at the outside of the 4-metre-circle.

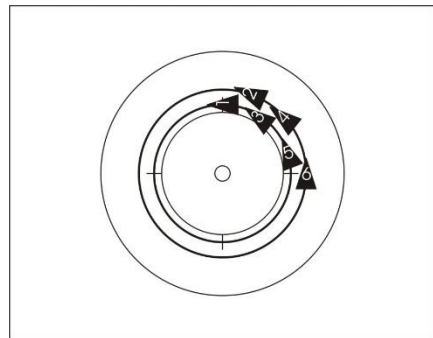

6316 b

Chain half circle raiser

All riders are riding around the 4-metre-circle in left-right position.

Rider 1 grabs with his right hand the right hand of rider 2. Rider 2 grabs with his left hand the left hand of rider 3. Rider 3 grabs with his right hand the right hand of rider 4. Rider 4 grabs with his left hand the left hand of rider 5. Rider 5 grabs with his right hand the right hand of rider 6.

All not connected arms have to be stretched sideways and horizontally. The figure ends when the 4-metre-circle is rounded half at the outside of the 4-metre-circle.

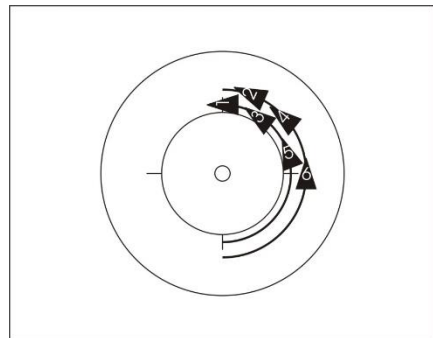

6317 a
6318 a

Chain circle raiser

All riders are riding around the 4-metre-circle in left-right position.

Rider 1 grabs with his right hand the right Hand of rider 2. Rider 2 grabs with his left hand the left hand of rider 3. Rider 3 grabs with his right hand the right hand of rider 4. Rider 4 grabs with his left hand the left hand of rider 5. Rider 5 grabs with his right hand the right hand of rider 6.

All not connected arms have to be stretched sideways and horizontally. The figure ends when the 4-metre-circle is rounded completely at the outside of the 4-metre-circle.

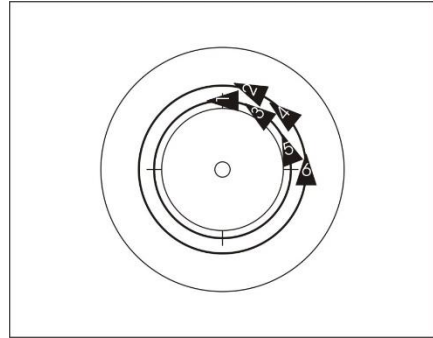

6317 b
6318 b

Saddlegrip half circle

All riders are riding around the 4-metre-circle in left-right position.

Rider 1 grabs with both hands his handlebar. Rider 2 grabs with his left hand the saddle of rider 1. Rider 3 grabs with his left hand the saddle of rider 2. Rider 4 grabs with his left hand the saddle of rider 3. Rider 5 grabs with his left hand the saddle of rider 4. Rider 6 grabs with his left hand the saddle of rider 5.

The figure ends when the 4-metre-circle is rounded half at the outside of the 4-metre-circle.

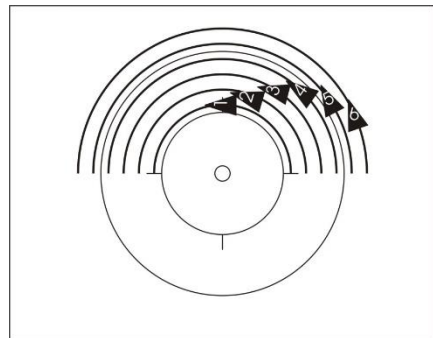

6321 a

Saddlegrip Circle

All riders are riding around the 4-metre-circle in left-right position.

Rider 1 grabs with both hands his handlebar. Rider 2 grabs with his left hand the saddle of rider 1. Rider 3 grabs with his left hand the saddle of rider 2. Rider 4 grabs with his left hand the saddle of rider 3. Rider 5 grabs with his left hand the saddle of rider 4. Rider 6 grabs with his left hand the saddle of rider 5.

The figure ends when the 4-metre-circle is rounded completely at the outside of the 4-metre-circle.

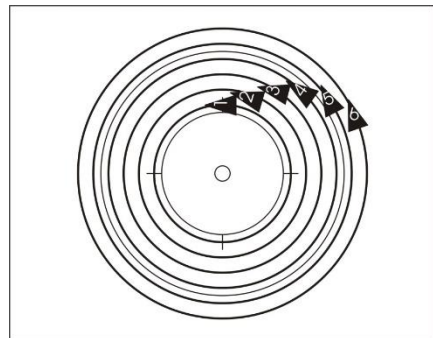

6321 b

Saddlegrip pass through

Starting position is the saddlegrip. Rider 1 and 2 are connected to each other with their left hands. Riders 2, 3, 4, 5 and 6 are connected to each other by saddle grip and will pass rider 1 at the inside. This way the riders execute a “pass through”. The figure when all riders are performing a saddlegrip or a saddlegrip-ring.

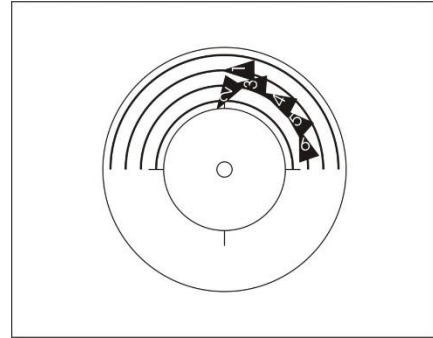

6322 a

Saddlegrip

All riders are riding around the 4-metre-circle in left-right position. Rider 1 grabs with both hands his handlebar. Rider 2 grabs with his left hand the saddle of rider 1. Rider 3 grabs with his left hand the saddle of rider 2. Rider 4 grabs with his left hand the saddle of rider 3. Rider 5 grabs with his left hand the saddle of rider 4. Rider 6 grabs with his left hand the saddle of rider 5.

Saddlegrip-ring

All riders are riding behind each other at the same distance between each other while riding around the centre of the riding-area. Rider 1 grabs with his left hand the saddle of rider 6. Rider 2 grabs with his left hand the saddle of rider 1. Rider 3 grabs with his left hand the saddle of rider 2. Rider 4 grabs with his left hand the saddle of rider 3. Rider 5 grabs with his left hand the saddle of rider 4. Rider 6 grabs with his left hand the saddle of rider 5.

Saddlegrip-ring

All riders are riding behind each other at the same distance between each other while riding around the centre of the riding-area.

Rider 1 grabs with his left hand the saddle of rider 6. Rider 2 grabs with his left hand the saddle of rider 1. Rider 3 grabs with his left hand the saddle of rider 2. Rider 4 grabs with his left hand the saddle of rider 3.

Rider 5 grabs with his left hand the saddle of rider 4. Rider 6 grabs with his left hand the saddle of rider 5.

The figure ends after the way of stretch of a complete circle around the centre of the riding-area.

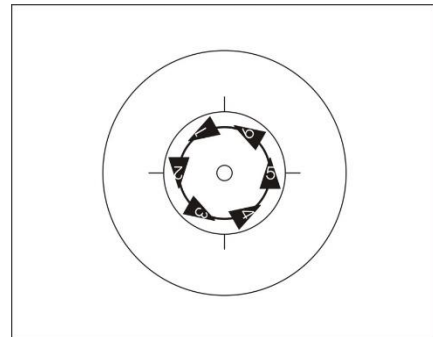

6323 a
6324 a
6324 b
6324 c

2 connected wingmill opposite direction door simultaneously

Two riders of each group are connected by grip-connection and are riding side by side. The distances between rider 1 and 2 has to be identical to the distance between rider 3 and 4. Both groups are riding with same distances between each other on the same axis around the centre of the riding-area. The inside riders of the groups are connected to each other by their left hands, above the centre of the riding-area, performing a wingmill.

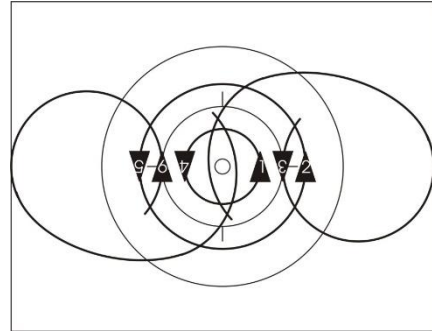

6331 b
6332 c
6332 d
6333 b

The two other riders are riding on the same, imaginary, axis which runs parallel to the short or long side of the riding-area. Each of the passing riders has to perform simultaneous twice a circle with same diametre and same speed through the doors of the wingmill.

The riders have to ride once simultaneously through the two outside doors and once simultaneously through the middle door. The way of stretch for the passing riders starts 2 metres before the first passing of the door and ends 2 metres after the last passing of the door.

The wingmill has to move until the mentioned way of stretch of the passing riders is completed.

3 connected wingmill

Each three riders of are connected by grip-connection and are riding side by side on an axis. The distances between rider 1 and 2 and between rider 2 and 3 has to be identical to the distances of rider 4 and 5 and between rider 5 and 6. Both groups are riding with same distances between each other at the same axis, while riding at the same distances around the centre

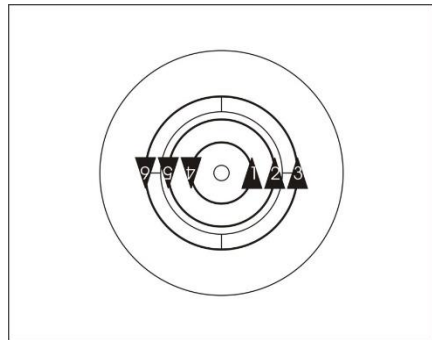

6341 a
6342 a
6342 b
6342 c
6343 a
6343 b
6343 c
6343 d
6343 e
6343 f
6344 a
6344 b
6344 c
6344 d

of the riding-area. The inside riders of the groups are connected to each other by their left hands, above the centre of the riding-area.

The figure ends after a complete surrounding around the centre of the riding-area.

3 connected wingmill half surrounding 6 single rings right

Each three riders of are connected by grip connection and are riding side by side on an axis. The distances between rider 1 and 2 and between rider 2 and 3 must be identical to the distances of rider 4 and 5 and between rider 5 and 6. Both groups are riding with same distances between each other at the same axis, while riding at the same distances around the centre of the riding-area. The inside riders of the groups are connected to each other by their left hands, above the centre of the riding-area.

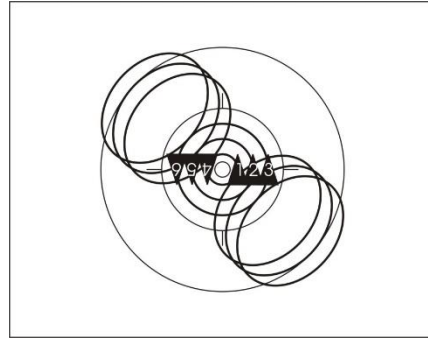

6341 b
6345 a

During the figure the grip connections have to be released simultaneously and in motion. Each rider performs a single ring right simultaneously and uniform. After the single rings the riders have to close the grip connection simultaneously and in motion.

The 3 connected wingmill has to be performed 2 metres before and 2 metres after the single rings right.

The figure ends after a half surrounding around the centre of the riding-area.

Single ring right (8.3.030)

3 connected wingmill 6 single rings right

Each three riders of are connected by grip-connection and are riding side by side on an axis. The distances between rider 1 and 2 and between rider 2 and 3 must be identical to the distances of rider 4 and 5 and between rider 5 and 6. Both groups are riding with same distances between each other at the same axis, while riding at the same distances around the centre of the riding-area. The inside riders of the groups are connected to each other by their left hands, above the centre of the riding-area.

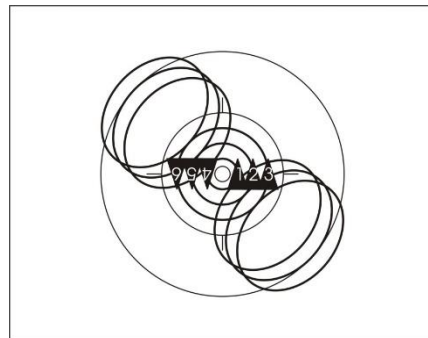

6341 c
6345 b

During the figure the grip connections have to be released simultaneously and in motion. Each rider performs a single ring right simultaneously and uniform. After the single rings the riders have to close the grip connection simultaneously and in motion.

The 3 connected wingmill has to be performed 2 metres before and 2 metres after the single rings right.

The figure ends after a complete surrounding around the centre of the riding-area.

Single ring right (8.3.030)

2 connected wingmill

Each two riders of each group are connected and are riding side by side on an axis. The distances between rider 1 and 2 has to be identical to the distance between rider 3 and 4 and between rider 5 and 6. All groups are riding with same distances between each other, while riding at the same distances around the centre of the riding-area. The inside riders of the groups are connected to each other by their left hands, above the centre of the riding-area.

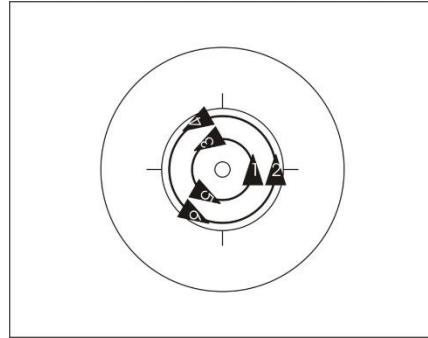

- 6351 a
- 6352 a
- 6352 d
- 6352 e
- 6353 a
- 6353 b
- 6353 c
- 6353 d
- 6353 e
- 6353 f
- 6354 a
- 6354 b
- 6354 c
- 6354 d

The figure ends after a complete surrounding around the centre of the riding-area.

2 connected wingmill half surrounding 2 connected single rings right

Each two riders of each group are connected and are riding side by side on an axis. The distances between rider 1 and 2 has to be identical to the distance between rider 3 and 4 and between rider 5 and 6. All groups are riding with same distances between each other, while riding at the same distances around the centre of the riding-area. The inside riders of the groups are connected to each other by their left hands, above the centre of the riding-area.

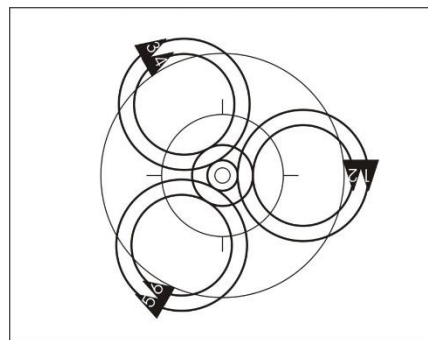

- 6351 b
- 6352 b
- 6355 a

During the figure the grip connection between the inside riding riders have to be released simultaneous and in motion. The three groups of riders perform a 2 connected single ring right with same size and uniform. After the 2 connected single rings right the riders have to close the grip connection simultaneously and in motion. The 2 connected wingmill has to be performed 2 metres before and 2 metres after the single rings. The figure ends after a half surrounding around the centre of the riding-area.

2 connected single ring right (8.3.034)

2 connected wingmill 2 connected single rings right

Each two riders of each group are connected and are riding side by side on an axis. The distances between rider 1 and 2 has to be identical to the distance between rider 3 and 4 and between rider 5 and 6. All groups are riding with same distances between each other, while riding at the same distances around the centre of the riding-area.

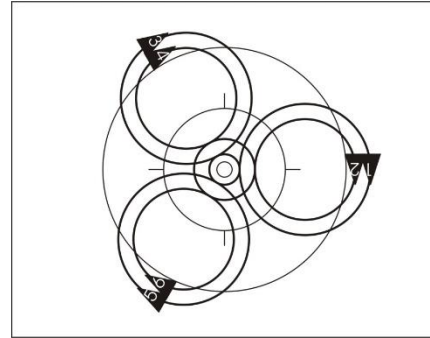

6351 c
6352 c
6355 b

The inside riders of the groups are connected to each other by their left hands, above the centre of the riding-area.

During the figure the grip connection between the inside riding riders have to be released simultaneous and in motion. The three groups of riders perform a 2 connected single ring right with same size and uniform.

After the 2 connected single rings right the riders have to close the grip connection simultaneously and in motion.

The 2 connected wingmill has to be performed 2 metres before and 2 metres after the single rings

The figure ends after a complete surrounding around the centre of the riding-area.

2 connected wingmill half surrounding 6 single rings right

Each two riders of each group are connected and are riding side by side on an axis. The distances between rider 1 and 2 has to be identical to the distance between rider 3 and 4 and between rider 5 and 6. All groups are riding with same distances between each other, while riding at the same distances around the centre of the riding-area.

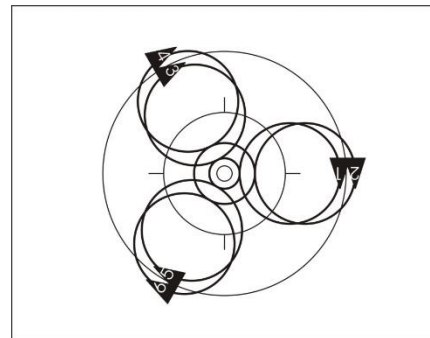

6351 d
6355 c

The inside riders of the groups are connected to each other by their left hands, above the centre of the riding-area.

During the figure the grip connections have to be released simultaneously and in motion. Each rider performs a single ring right simultaneously and uniform. After the single rings the riders have to close the grip connection simultaneously and in motion.

The 2 connected wingmill has to be performed 2 metres before and 2 metres after the single rings

The figure ends after a half surrounding around the centre of the riding-area.

Single ring right (8.3.030)

2 connected wingmill 6 single rings right

Each two riders of each group are connected and are riding side by side on an axis. The distances between rider 1 and 2 has to be identical to the distance between rider 3 and 4 and between rider 5 and 6. All groups are riding with same distances between each other, while riding at the same distances around the centre of the riding-area. The inside riders of the groups are connected to each other by their left hands, above the centre of the riding-area.

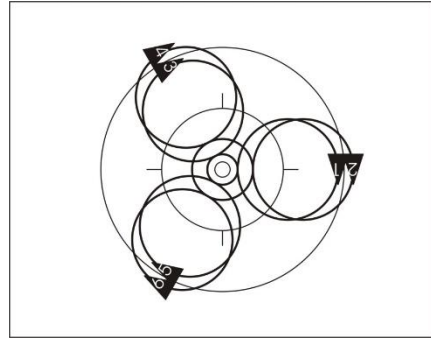

6351 e
6355 d

During the figure the grip connections have to be released simultaneously and in motion. Each rider performs a single ring right simultaneously and uniform. After the single rings the riders have to close the grip connection simultaneously and in motion.

The 2 connected wingmill has to be performed 2 metres before and 2 metres after the single rings

The figure ends after a complete surrounding around the centre of the riding-area.

Single ring right (8.3.030)

2 connected wingring

Each two riders of each group are connected by grip-connection and are riding side by side on an axis. The distances between rider 1 and 2 has to be identical to the distance between rider 3 and 4 and between rider 5 and 6. All groups are riding with same distances between each other around the centre of the riding-area. The inside riders of the groups are connected with their right hand to the left hand of their partner in front.

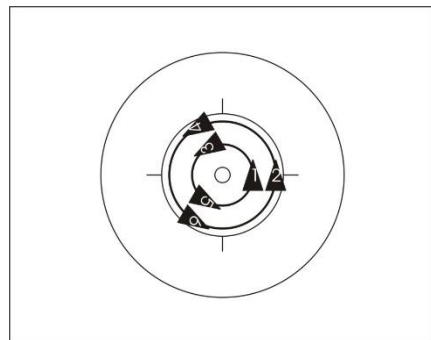

6362 a
6363 a
6363 b
6363 c
6363 d
6363 e
6363 f
6364 a
6364 b
6364 c
6364 d

The figure ends after a complete surrounding around the centre of the riding-area.

3 connected wingmill mill with 4 following each other circle

Each three riders of are connected by grip connection and are riding side by side on an axis. The distances between rider 1 and 2 and between rider 2 and 3 must be identical to the distances of rdier 4 and 5 and between rider 5 and 6. Both groups are riding with same distances between each other on the same axis, while riding at the same distances around the centre of the riding-area. The inside riders of the groups are connected with their left hands, above the centre of the riding-area.

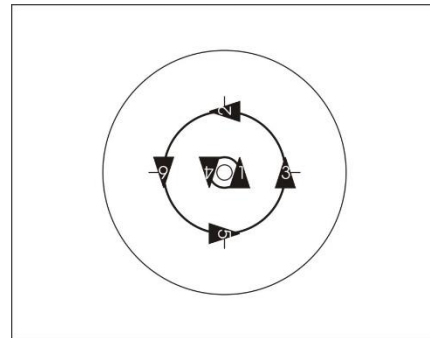

6371 a
6372 a
6372 b
6373 a

During the figure the 4 outside riding riders have to release their grip connections simultaneously and in motion and ride with same distances between each other and at same distances to the 4-metre-circle once completely around the 4-metre-circle. During the outside riders are riding around the 4-metre-circle the 2 inside riding riders have to surround the centre of the riding-area at least once completely. The grip connections have to be released before starting the circle simultaneously and in motion. After finishing the circle the grip connections have to be closed simultaneously and in motion. The figure ends after reaching the position of the wingmill again.

3 connected wingring insidering with 4 following each other circle

Each three riders of each group are connected by grip connection and are riding side by side on an axis. The distances between rider 1 and 2 and between rider 2 and 3 has to be identical to the distance between rider 4 and 5 and between rider 5 and 6. All groups are riding with same distances between each other around the centre of the riding-area. The inside riders of the groups are connected with their right hand to the left hand of their partner in front.

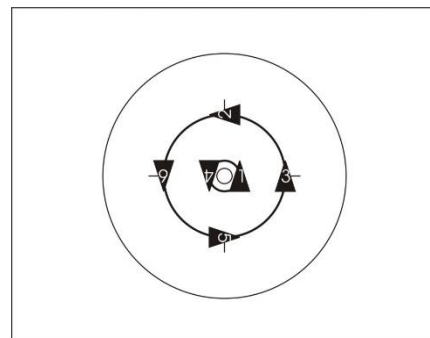

6371 b
6372 c
6372 d
6373 b

During the figure the 4 outside riding riders have to release their grip connections simultaneously and in motion and ride with same distances between each other and at same distances to the 4-metre-circle once completely around the 4-metre-circle. During the outside riders are riding around the 4-metre-circle the 2 inside riding riders have to surround the centre of the riding-area at least once completely. The grip connections have to be released before starting the circle simultaneously and in motion. After finishing the circle the grip connections have to be closed simultaneously and in motion. The figure ends after reaching the position of the wingring again.

2 connected wingmill mill with 3 spinnings

Each two riders of each group are connected and are riding side by side on an axis. The distances between rider 1 and 2 has to be identical to the distance between rider 3 and 4 and between rider 5 and 6. All groups are riding with same distances between each other, while riding at the same distances around the centre of the riding-area. The inside riders of the groups are connected to each other by their left hands, above the centre of the riding-area.

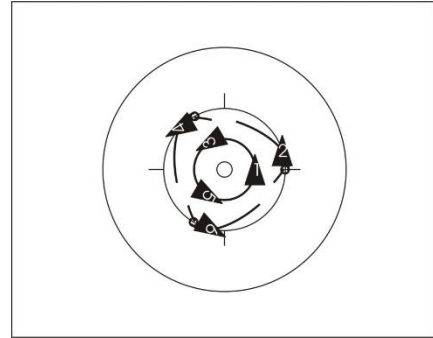

6378 c

During the figure the 3 outside riding riders have to release their grip connections simultaneously and in motion and perform 3 spinnings simultaneously. After the spinnings the grip connections have to be closed simultaneously and in motion. The 3 inside riding riders have to surround in the meantime the centre of the riding-area at least once completely. Before releasing and after closing the grip connection the wingmill has to be performed at least 2 metres.

Spinings (8.3.037)

Mill

All riders are following each other with same distances to each other while riding around the centre of the riding-area. All riders have the same distance to the centre of the riding-area. During the figure all riders are connected with their left hands, above the centre of the riding-area. The figure has to be performed within the 4-metre-circle. The figure ends not before a complete surrounding around the centre of the riding-area is performed.

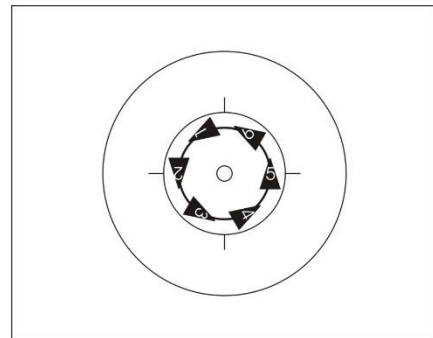

6386 a
6387 a
6387 b
6387 c
6388 a
6388 b
6388 c
6388 d
6388 e
6388 f
6389 a
6389 b
6389 c

Mill 6 single rings right

All riders are following each other with same distances to each other while riding around the centre of the riding-area. All riders have the same distance to the centre of the riding-area. During the figure all riders are connected by their left hands, above the centre of the riding-area. The figure has to be performed within the 4-metre-circle.

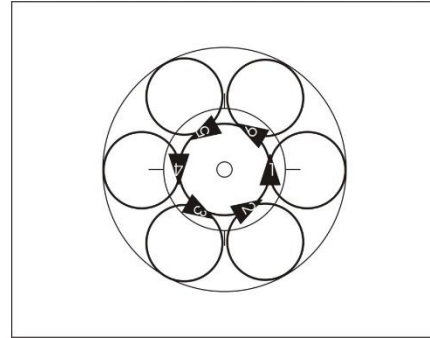

6386 b

During the figure the grip connections have to be released simultaneously and in motion. Each rider performs simultaneously a same sized and uniform single ring right. After the single rings the riders have to close the grip connection simultaneously and in motion.

The mill has to be performed 2 metres before of and 2 metres after the single ring right.

The figure ends not before a complete surrounding around the centre of the riding-area is performed.

Single ring right (8.3.030)

Insidering around 2

Four riders are riding with same distances between each other around the centre of the riding-area. Each of the four riders grabs with his right hand the left hand of the rider in front of him. The two other riders are standing without moving around the midpoint of the riding-area. They are connected with their right hand to the left hand of the partner.

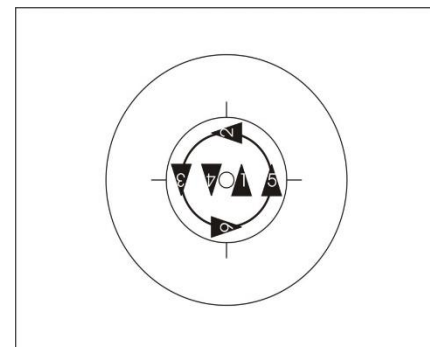

6396 a
6396 b
6396 c
6396 d
6396 e
6397 a
6397 b
6397 c

The figure ends after executing the way of stretch of a complete circle around the centre of the riding-area. The figure has to be performed within the 4-metre-circle.

Insidering

All riders are riding at the same distance, following each other, around the centre of the riding-area. Each rider grabs with the right hand the left hand of the rider in front of him. The figure has to be performed within the 4-metre-circle. The figure ends after executing the way of stretch of a complete circle around the centre of the riding-area.

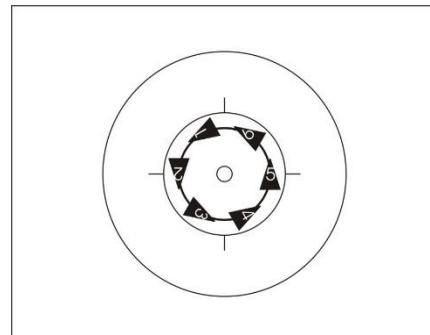

6403 a
6403 b
6403 c
6403 d
6403 e
6404 a
6404 b
6404 c

Ring with opposite grips

All riders are riding at the same distance, following each other, around the centre of the riding-area. Rider 1, 3 and rider 5 grab with their left hands into the left hands of the riders in front of them. Rider 2, 4 and rider 6 grab with their right hands into the right hands of the riders in front of them. The figure ends after executing the way of stretch of a complete circle around the centre of the riding-area. The figure has to be executed within the 4-metre-circle.

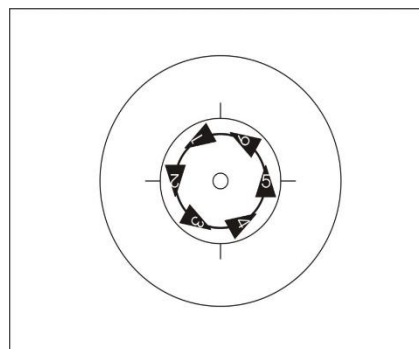

6412 a
6412 c
6412 d
6412 e
6412 f
6413 a
6413 c
6413 d

Ring with opposite grips half surrounding followed by insidering half surrounding

Starting position is the ring with opposite grips. After performing the way of stretch of a half circle all riders have to release and to close simultaneously and in motion their grip connection into the position inside ring. The figure ends after the way of stretch of a half circle in the position inside ring.

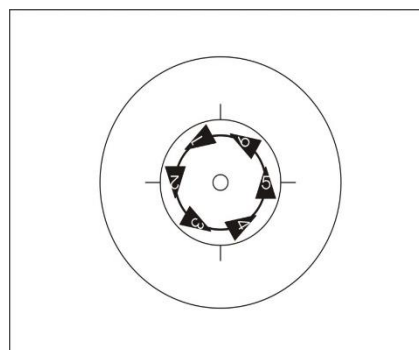

6412 b
6413 b

Ring with opposite grips

All riders are riding at the same distance, following each other, around the centre of the riding-area. Rider 1, 3 and rider 5 grab with their left hands into the left hands of the riders in front of them. Rider 2, 4 and rider 6 grab with their right hands into the right hands of the riders in front of them. The figure has to be performed within the 4-metre-circle.

Insidering

All riders are riding at the same distance, following each other, around the centre of the riding-area. Each rider grabs with the right hand the left hand of the rider in front of him. The figure has to be performed within the 4-metre-circle.

Outsidering

All riders are riding with same distance, following each other, around the centre of the riding-area. Each rider grabs with his left hand the right hand of the rider in front of him. The figure has to be performed within the 4-metre-circle. The figure ends after executing the way of stretch of a complete circle around the centre of the riding-area.

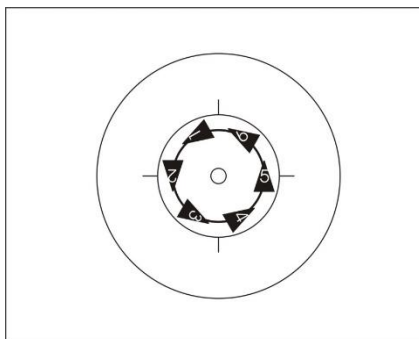

6417 a
6417 b
6417 c
6417 d
6417 e
6417 f
6418 a
6418 b
6418 c

Outsidering half surrounding followed by insidering half surrounding

Starting position is the outsidering. After performing the way of stretch of a half circle all riders release simultaneously their grip connection and grab simultaneously and in motion to the position inside ring (again grip connection). The figure ends after the way of stretch of a half circle in the position inside ring.

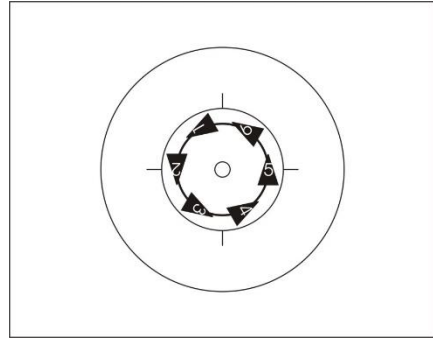

6417 f
6418 d

Outsidering

All riders are riding with same distance, following each other, around the centre of the riding-area. Each rider grabs with his left hand the right hand of the rider in front of him. The figure has to be performed within the 4-metre-circle.

Insidering

All riders are riding at the same distance, following each other, around the centre of the riding-area. Each rider grabs with the right hand the left hand of the rider in front of him. The figure has to be performed within the 4-metre-circle.

Half door

Two riders are standing on the longitudinal or transverse axis. They are connected to each other with their left hands through a hand-in-hand grip-connection above the middle of the riding-area. The not connected arms of the riders are stretched sideways, horizontally. So the riders are building a door.

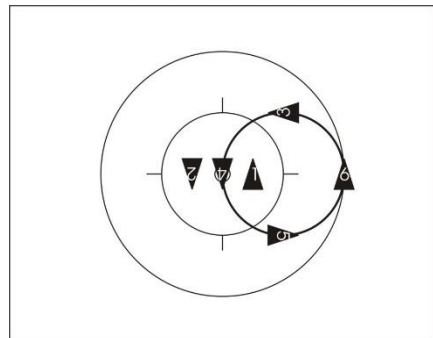

6425 a
6426 a
6427 a
6427 c
6428 a

The four other riders are riding at equal distances following each other each once through the door. Each of the two riders is connected with his right hand to the left hand of the the other rider.

The figure starts 2 metres before the first rider is riding through the door and ends 2 metres after the last second rider has passed the door. The door has to stand still at least until the riders which were passing the door, have finished their total way of stretch.

Door

Two riders are standing on the longitudinal or transverse axis. They are connected to each other with their left hands through a hand-in-hand grip-connection above the middle of the riding-area. The not connected arms of the riders are stretched sideways, horizontally. So the riders are building a door.

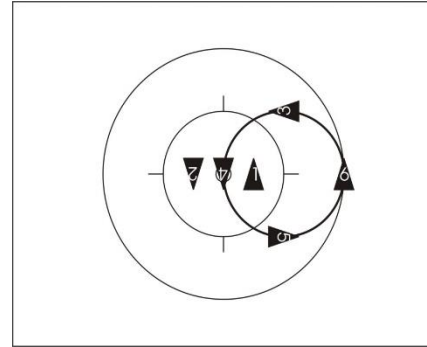

6425 b
6426 b
6427 b
6427 d
6428 b

The four other riders are riding at equal distances following each other each twice through the door. Each of the two riders is connected with his right hand to the left hand of the the other rider.

The figure starts 2 metres before the first rider is riding through the door and ends 2 metres after the **last second** rider has passed the door. The door has to stand still at least until the riders which were passing the door, have finished their total way of stretch.

Half opposite direction door

Two riders are standing on the longitudinal or transverse axis of the riding-area. They are connected by hand-in-hand grip connection, which is situated above the middle of the riding-area. The other arms of the standing riders are stretched sideways, horizontally. So they are building a door.

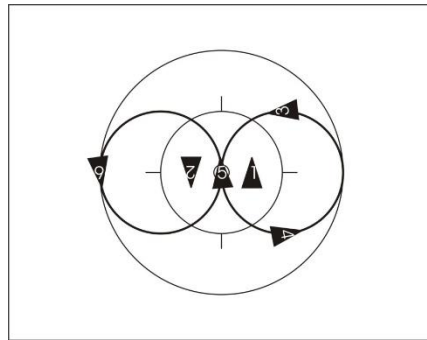

6425 c
6426 c
6427 e
6427 g
6428 c

Two riders form a group (two groups are shifted ¼ circle) and are riding with same distances following each other. Each of these riders will ride through the door once.

The figure starts 2 metres before the first rider is riding through the door and ends 2 metres after the **last second** rider has passed the door. The door has to stand still at least until the riders which were passing the door, have finished their total way of stretch.

Opposite direction door

Two riders are standing on the longitudinal or transverse axis of the riding-area. They are connected by hand-in-hand grip connection, which is situated above the middle of the riding-area. The other arms of the standing riders are stretched sideways, horizontally. So they are building a door.

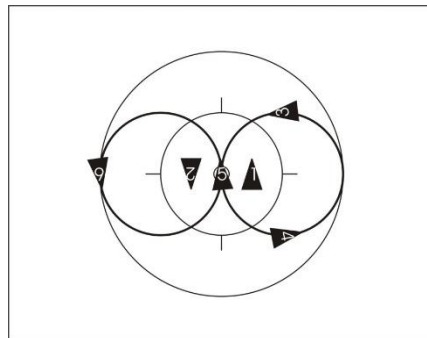

6425 d
6426 d
6427 f
6427 h
6428 d

Two riders form a group (two groups are shifted ¼ circle) and are riding with same distances following each other. Each of these riders will ride through the door twice.

The figure starts 2 metres before the first rider is riding through the door and ends 2 metres after the **last second** rider has passed the door. The door has to stand still at least until the riders which were passing the door, have finished their total way of stretch.

Opposite direction door simultaneously

Two riders are standing on the longitudinal or transverse axis of the riding-area. They are connected by hand-in-hand grip connection, which is situated above the middle of the riding-area. The other arms of the standing riders are stretched sideways, horizontally. So they are building a door.

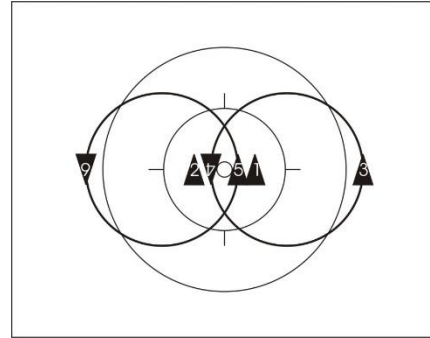

6425 e
6426 e
6427 i
6427 j
6428 e

Two riders form a group (two groups) and are riding with same distances following each other. Each of these riders will ride through the door twice simultaneously.

At the moment riders pass the door this will be always performed simultaneously by two riders; one rider from each group.

The figure starts 2 metres before the first rider is riding through the door and ends 2 metres after the **last second** rider has passed the door. The door has to stand still at least until the riders which were passing the door, have finished their total way of stretch.

Mill opposite direction door

Two riders are connected with their left hands and are performing a mill in the middle of the riding-area. Their right arms are stretched sideways, horizontally.

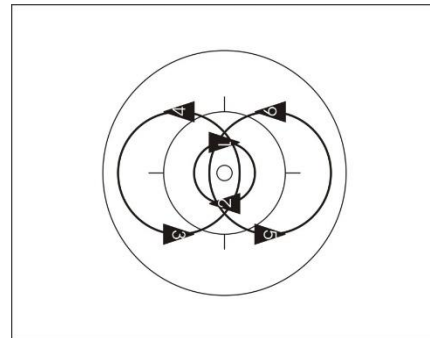

6428 h

Two riders form a group (two groups) and are riding with same distances following each other twice through the door; formed by the moving mill. At the moment riders pass the door of the mill it has always to be performed simultaneously by two riders; one rider from each group.

The figure starts 2 metres before the first rider is riding through the door and ends 2 metres after the **last second** rider has passed the door. The mill has to move at least until the riders which were passing the door, have finished their total way of stretch.

Double door

Three riders are standing on the longitudinal or transverse axis of the riding-area and are connected by hand-in-hand grip performing a double door. The central rider is standing at the middle of the riding-area. The distance between rider 1 and 2 has to be identical to the distance between rider 2 and 3. The other arms of the standing riders are stretched sideways, horizontally. So they are building a double door.

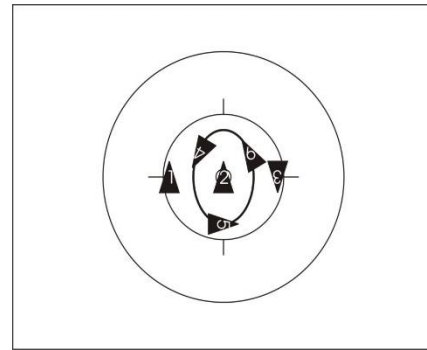

6436 a
6437 a
6438 a

The other 3 riders have to ride with same distances following each other through each space of the two doors twice, while circling around the rider in standing in the middle. The figure starts 2 metres before the first rider is riding through the door and ends 2 metres after the last second rider has passed the door. The door has to stand still at least until the riders which were passing the door, have finished their total way of stretch.

Double door opposite direction

Three riders are standing on the longitudinal or transverse axis of the riding-area and are connected by hand-in-hand grip performing a double door. The central rider is standing at the middle of the riding-area. The distance between rider 1 and 2 has to be identical to the distance between rider 2 and 3. The other arms of the standing riders are stretched sideways, horizontally. So they are building a double door.

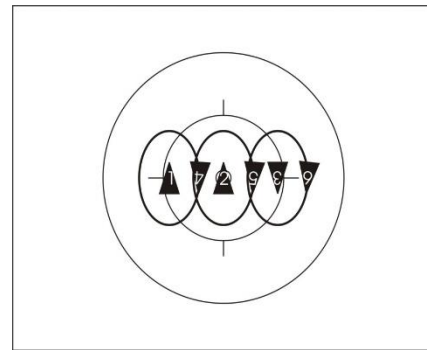

6436 b
6437 b
6438 b

The other three riders are riding on a, imaginary, axis which runs parallel to the short or long side of the riding-area. Each rider will surround one of the riders building a double door.

During the figure each rider has to pass at least twice a space of the double door.

The figure starts 2 metres before the first rider is passing the door and ends 2 metres after the last rider has passed the door.

The door has to stand still at least until the riders which were passing the door, have finished their total way of stretch.

Double door moving synchronous door

6439 a
6439 b
6440 a

Three riders are standing, at equal distance from each other, on the longitudinal or transverse axis. The rider in the middle is standing in the middle of the riding-area. The three riders are connected by hand-in-hand grip. The other arms are stretched sideways horizontally in order to build a double door.

The three other riders are riding at equal distance from each other in an individual and synchronised way in order to ride through the double door. Each rider shall pass twice. While rider 4 is riding through a door, the other two riders are passing the door on the outside. Afterwards rider 5 and 6 are each riding through a door, rider 4 is passing the door on the outside.

The figure starts two metres before the first rider rides through the door and ends two metres after the last rider has ridden through the door. The door has to stand still at least until the riders which were riding through the door, have finished their total way of stretch.

Half dooring

Two riders are standing on the longitudinal or transverse axis of the riding-area. They are connected with their left hands by hand-in-hand grip connection, which is situated above the middle of the riding-area. The other arms are stretched, sideways, horizontally. So they are building a door.

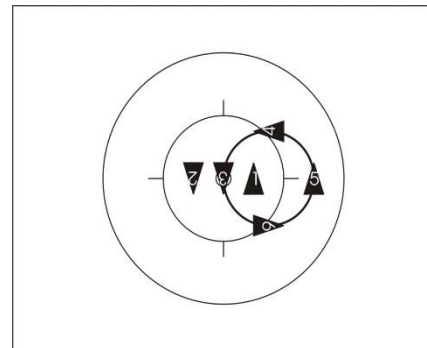

6452 a
6453 a

The other four riders are riding, with same distances following each other once through the door. The passing riders are connected by their left hand to the right hand of the rider in front of him.

The door has to stand still at least until the riders which were passing the door, have finished their total way of stretch.

Dooring

Two riders are standing on the longitudinal or transverse axis of the riding-area. They are connected with their left hands by hand in- hand grip connection, which is situated above the middle of the riding-area. The other arms are stretched, sideways, horizontally. So they are building a door.

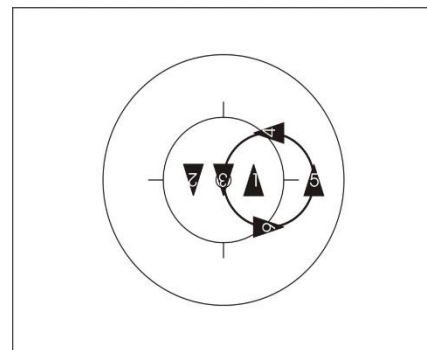

6452 b
6453 b

The other four riders are riding, with same distances following each other twice through the door. The passing riders are connected by their left hand to the right hand of the rider in front of him.

The door has to stand still at least until the riders which were passing the door, have finished their total way of stretch.

Half double dooring

Three riders are standing on the longitudinal- or transverse axis and are connected by hand-in-hand grip. The rider in the middle is standing on the centre of the riding-area. So they are building a double door. The not connected arms are stretched sideways, horizontally.

The other three riders are riding, with same distances to each other, each once, through both spaces of the door.

The passing riders are connected with their left hands to the right hands of the rider in front.

The door has to stand still at least until the riders which were passing the door, have finished their total way of stretch.

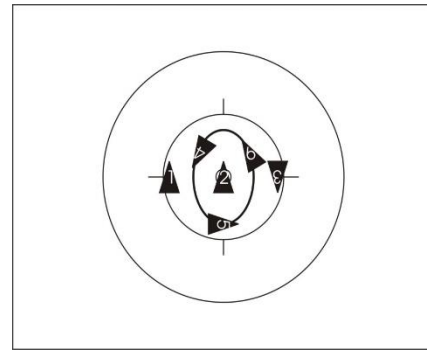

6462 a
6463 a

Double dooring

Three riders are standing on the longitudinal or transverse axis and are connected by hand-in-hand grip. The rider in the middle is standing on the centre of the riding-area. So they are building a double door. The not connected arms are stretched sideways, horizontally.

The other three riders are riding, with same distances to each other, each twice, through both spaces of the door.

The passing riders are connected with their left hands to the right hands of the rider in front.

The door has to stand still at least until the riders which were passing the door, have finished their total way of stretch.

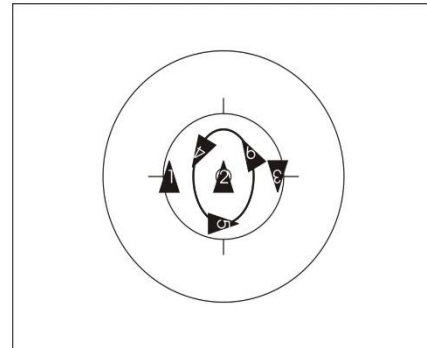

6462 b
6463 b

Star inside 6 single rings left

All riders are following each other, with the same distances between each other, around the 4-metre-circle. During the figure all riders perform a single ring left with same size and uniform. After finishing the single rings all riders will ride to the middle of the riding-area and perform all, simultaneously, a star by hand-in-hand grip connection. Each rider has to be connected with two other riders. The bike head tubes have to point to the middle of the riding-area.

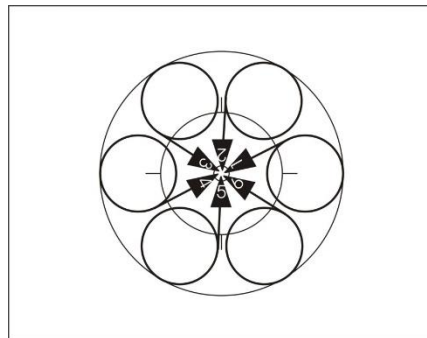

6471 a

Single ring left (8.3.029)

Star inside

All riders are standing, with same distances between each other, without moving, around the middle of the riding-area. All are connected to each other by hand-in-hand grip connection. The bike head tubes have to point to the middle of the riding-area.

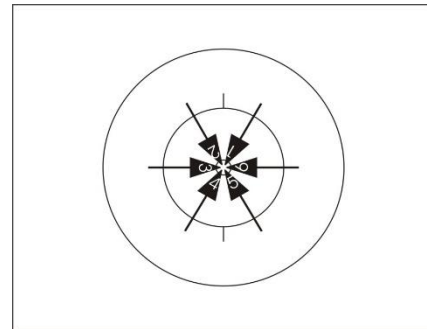

6472 a
6472 b
6472 c
6472 d

Star opposite direction

All riders are standing, with same distances between each other, without moving, around the middle of the riding-area. All are connected to each other by hand-in-hand grip-connection. The bike head tube of rider 1 and the rear wheel of rider 4, the rear wheel of rider 2 and the and the bike head tube of rider 5 and the bike head tube of rider 3 and the rear wheel of rider 6 have to point to the middle of the riding-area.

6482 a
6482 b
6482 c
6482 d

Star outside

All riders are standing, with same distances between each other, without moving, around the middle of the riding-area. All are connected to each other by hand-in-hand grip connection. The bike rear wheels have to point to the middle of the riding-area.

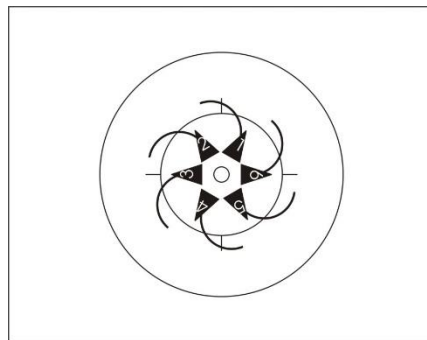

6481 a
6483 a
6483 b

Star outside 6 single rings left

All riders are following each other, with same distances between each other, around the 4-metre-circle. During the figure all riders perform a single ring left with same size and uniform. After finishing the single rings all riders will ride to the middle of the riding-area and perform all, simultaneously, a star by hand-in-hand grip connection. The bike rear wheels have to point to the middle of the riding-area.

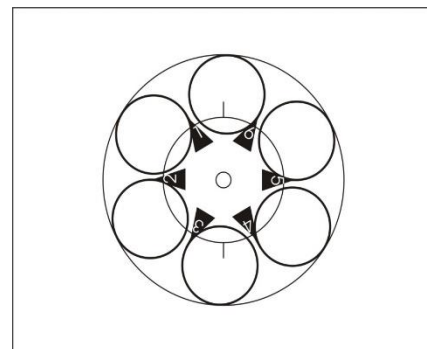

6481 b
6483 c

Single ring left (8.3.029)

Two stars inside ½ turn on the spot

Starting position are two stars inside.
From the position two stars inside all riders disconnect the grip connection and perform a half turn on the spot. The figure ends with two stars outside.

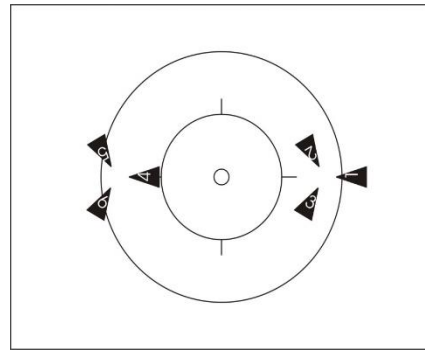

6485 a

Two stars inside

Three riders each are standing, with same distances between each other, without moving, around a spot of the riding-area. They are connected to each other by hand-in-hand grip connection. The bike head tubes have to point to the spots of the riding-area. The used spots for the stars have the same distances to the centre of the riding-area and are located at the longitudinal axis.

½ turn on the spot (8.3.040)

Two stars outside

Three riders each are standing, with same distances between each other, without moving, around a spot of the riding-area. They are connected to each other by hand-in-hand grip connection. The bikes rear wheels have to point to the spots of the riding-area. The used spots for the stars have the same distances to the centre of the riding-area and are located at the longitudinal axis.

Star inside ½ turn on the spot

Starting position is the star inside.
From the position star inside all riders disconnect the grip connection and perform a half turn on the spot. The figure ends in the star outside.

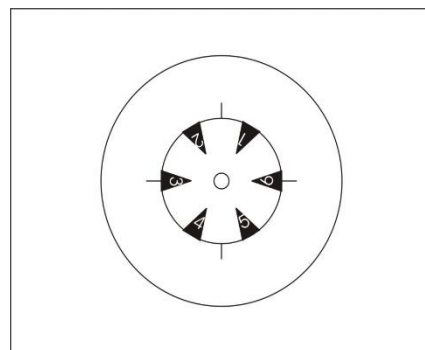

6486 a

Star inside (8.3.038)

½ turn on the spot (8.3.040)

Star outside (8.3.039)

Star inside 1 turn on the spot

Starting position is the Star inside.
From the position star inside all riders disconnect the grip connection and perform one turn on the spot. The figure ends in the star inside.

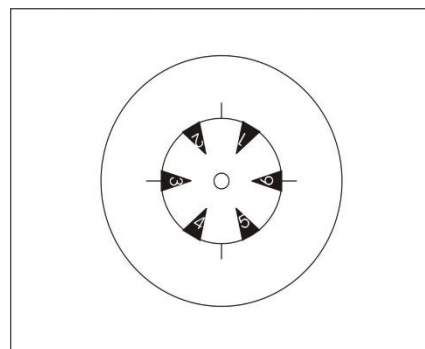

6486 b

Star inside (8.3.038)

1 turn on the spot (8.3.041)

2 connected raiser turn on the spot (T)

From a half tour on the tactical enlargement of the turn(s) on the spot is possible up to three half turns in maximum.

Three groups of each 2 riders. The riders of each group are connected by hand-in-hand grip. All riders are situated on the same imaginary axis at the riding-area. The distance between rider 1 and 2 is the same as the distance between rider 3 and 4 and the same as the distance between rider 5 and 6. During the figure the grip connections will be released simultaneously and all riders perform a turn on the spot. The grip connections have to be closed simultaneously, the riders have to stand still without moving.

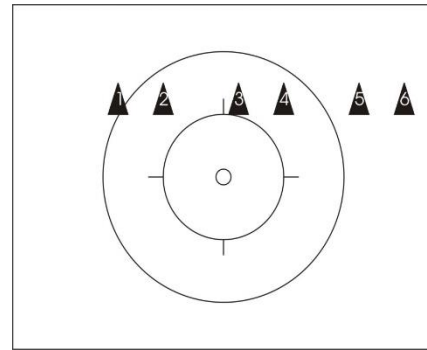

6496 a
6496 b
6496 c

3 connected raiser turn on the spot (T)

From a half tour on the tactical enlargement of the turn(s) on the spot is possible up to three half turns in maximum.

2 groups of each 3 riders. The riders of each group are connected by hand-in-hand grip. All riders are situated on the same imaginary axis at the riding-area. The distance between rider 1 and 2, between rider 2 and 3, between rider 4 and 5 and between rider 5 and 6 has to be identical. During the figure the grip connections will be released simultaneously and all riders perform a turn on the spot. The grip connections have to be closed simultaneously, the riders have to stand still without moving.

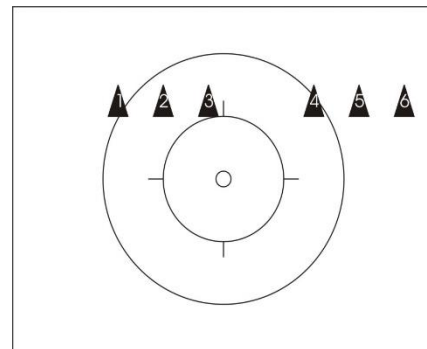

6496 d
6496 e
6496 f

6 connected raiser turn on the spot (T)

From a half tour on the tactical enlargement of the turn(s) on the spot is possible up to three half turns in maximum.

All riders are connected to each other by hand-in-hand grip and are standing on the same imaginary axis at the riding-area. The distance between rider 1 and 2, between 2 and 3, between 3 and 4, between 4 and 5, between 5 and 6 has to be identical. During the figure the grip connections will be released simultaneously and all riders will perform, a turn on the spot. The grip connections have to be closed simultaneously, the riders have to stand still without moving.

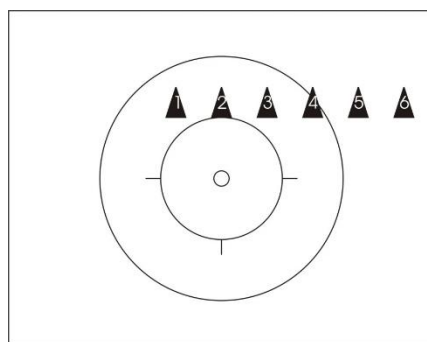

6496 g
6496 h
6496 i

(text modified on 01.01.16; 01.01.17)